

Architecture

Technical Manual

kuraray

Trosifol® SentryGlas®

Imprint

Publisher:

Kuraray Europe GmbH
53840 Troisdorf, Germany

Layout:

Katja Dynewski-Zeimet
Werbung · Events · PR
53343 Wachtberg, Germany

About our Trosifol® and SentryGlas® Technical Manual

Architecture

Dear User,

This is the 1st edition of our Trosifol® and SentryGlas® Technical Manual Architecture. It has been conceived specifically for users and leverages the many years of experience from within the Kuraray PVB and ionoplast interlayers Team. It is a useful and informative tool to help with the production of high quality laminated safety glass. This guide is not only helpful for the specification and deployment of architecture PVB and ionoplast interlayers, but also provides a lot of other information and recommendations on laminating equipment for use with other Trosifol® PVB and SentryGlas® ionoplast interlayers.

We trust that this information will serve as a useful guide for you in the production of high-quality laminated safety glass. If you need further information or assistance about glass laminating, please contact your local Sales or Technical Service representatives for support.

Your Kuraray Team



Product lines

Contents



➔	CHAPTER 1	07-11
	INTRODUCTION	
	1.1. Interlayer strength, depth and capabilities	08-09
	1.2. History of Trosifol® and Butacite® PVB Interlayer, SentryGlas® ionoplast Interlayer	10-11



➔	CHAPTER 2	13-36
	PRODUCTION AND LOGISTICS	
	2.1. Production of polyvinyl butyral resin	14
	2.2. Raw materials for PVB film production	15

2.3. Trosifol® production	16
2.4. Trosifol® glass adhesion	17-19
2.5. Product dimensions	20-24
2.6. Packaging type	25-28
2.7. SentryGlas® packaging	29
2.8. Product labels	30-31
2.9. Delivery form Trosifol® Architecture	32-35
2.9. Trosifol® roll length calculation	36



➔	CHAPTER 3	37-44
	GLASS PRODUCTION	
	3.1. Glass production / Glass types	38
	3.2. Fully tempered and heat-strengthened glass	39-40
	3.3. Flatness of tempered and heat strengthened glass	41
	3.4. Post treatment of annealed glass	42
	3.5. Glass coating	43
	3.6. Glass bending	44



➔	CHAPTER 4 PROCESSING OF ARCHITECTURAL LAMINATED SAFETY GLASS	45-76
	4.1. Introduction/basics	46-47
	4.2. Glass preparation and cleaning	48-50
	4.3. PVB roll storage and handling	51-55
	4.4. De-airing process	56-65
	4.5. Autoclave process	66-71
	4.6. Final inspection / post-treatment of laminated glass	72
	4.7. Laminated glass production without autoclave	73-75
	4.8. Further process instructions	76



➔	CHAPTER 5 ARCHITECTURAL GLAZING STANDARDS	77-100
	5.1. Overview of global architectural laminated safety glass standards	78-81
	5.2. Laminated safety glass resistance categories	82-83
	5.3. Safety performance test of laminated safety glass	84-86
	5.4. Security performance test of laminated safety glass	87-100
	5.5. Hurricane resistant security glazing	101-104



➔	CHAPTER 6 ACOUSTIC INTERLAYER	105-120
	6.1. Acoustic basics	106-108
	6.2. Acoustic glazing for facades and windows	109
	6.3. Laminated safety glass with Trosifol® Sound Control	110-114
	6.4. Measurement principle of glazing sound damping	115
	6.5. Acoustical properties of Trosifol® Sound Control Monolayer and Multilayer	116-119
	6.6. Trosifol™ Sound Lab calculation program	120



➔	CHAPTER 7 SPECIALIZED INTERLAYERS	121-134
	7.1. Trosifol® Spallshield® CPET	122-131
	7.2. UV Control PVB Interlayer	132-134



➔	CHAPTER 8 STRUCTURAL INTERLAYERS	135-161
	8.1. Introduction	136
	8.2. Trosifol® Extra Stiff PVB	137
	8.3. SentryGlas® Ionoplast interlayer	138-139
	8.4. Processing of SentryGlas®	140-156
	8.5. SentryGlas® Translucent White (TW) interlayer	157-158
	8.6. SentryGlas® Natural UV (NUV)	159
	8.7. SentryGlas® jumbo size	160
	8.8. SentryGlas® Xtra™ (SGX™)	160-165
	8.9. Stiffness and Elastic properties of SentryGlas® Ionoplast interlayer vs. Trosifol® Clear	161-170



➔	CHAPTER 9 TROUBLESHOOTING	171-176
	9.1. Troubleshooting	172-176

TOOLS & APPS 178

CONTACT 179



Photo: © Tom Bonner

Chapter 1

Introduction

Introduction

1.1. Interlayer strength, depth and capabilities

Delivering your window into the world of advanced interlayers for laminated safety glass, Kuraray's Advanced Interlayer Business is underpinned by decades of innovation, application knowledge, domain experience and market success.

OUR ADVANCED INTERLAYER PORTFOLIO – comprising Trosifol® PVB and SentryGlas® ionoplast interlayers – has continually revolutionized aesthetic, structural and functional design, fabrication and installation in the architectural and automotive/transportation segments.

Designed to benefit consumers, society and industry, our products are advancing the functionality of glass, while our engineers and consultants are setting new application benchmarks by collaborating on solutions that both sustain and inspire.

We are committed to helping you transform your mindset and take your applications to the next level – aesthetically, functionally and structurally. Enjoy greater design freedom and give your glazing strength, clarity, character and purpose with solutions that cover safety, security, sound insulation, UV/solar/energy management, color and print.

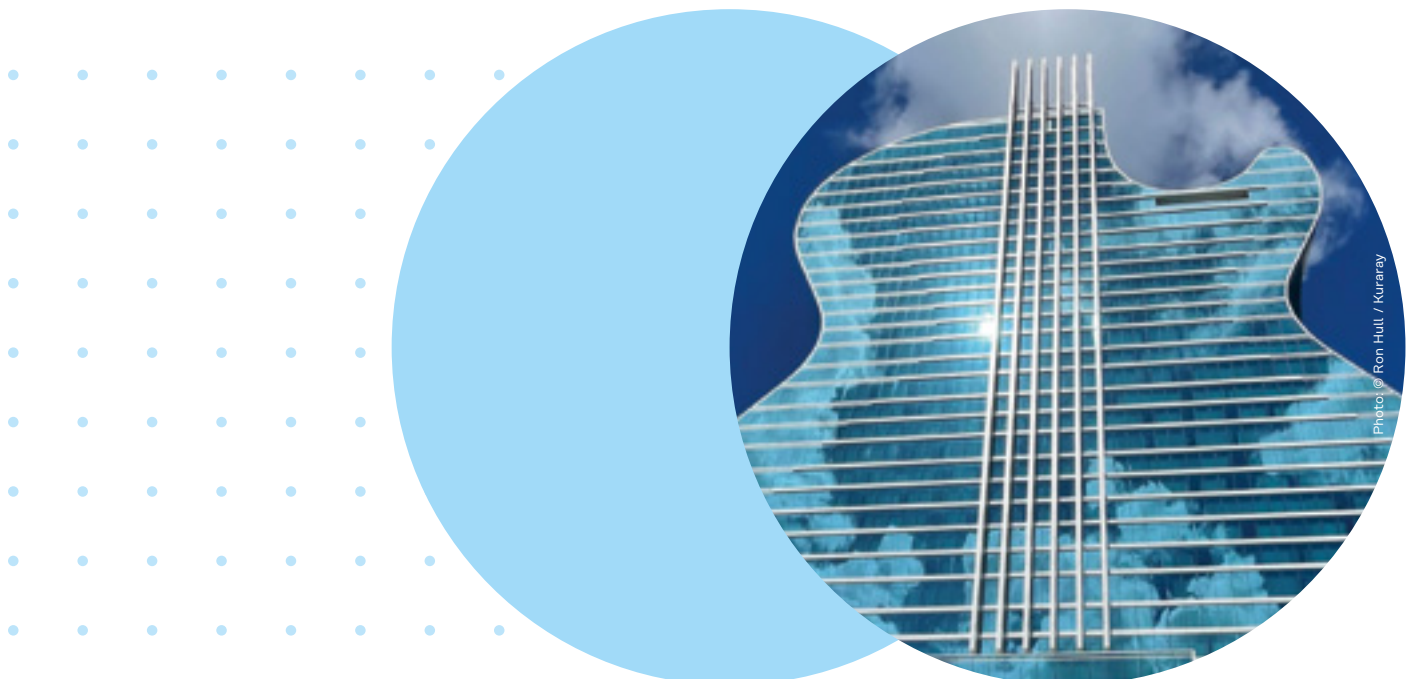



Photo: © Ron Hull / Kuraray

• Seminole Hard Rock Hotel & Casino, Hollywood, Florida

OUR DIVERSE PRODUCT RANGE, the broadest on the global market and our domain expertise create strength; and we channel this strength into helping you succeed. We strive to be your strongest ally and supporter and will help you navigate and conquer the ever-changing demands of the global glass industry. Worldwide production, R&D and support, means we are always by your side... no matter where you are.



Photo: © Gasprom

• Lakhta Tower, Saint Petersburg, Russia

1.2. History of Trosifol[®], SentryGlas[®] and Butacite[®]

1903

- First invention of laminated glass by French scientist Benedictus

1927

- Invention of polyvinyl butyral (PVB) polymer by the Canadian chemists Mathison and Skirrow

1938

- DuPont invents Butacite[®] PVB interlayer and introduces the first PVB interlayer to the automotive market

1950

- The American Standards Association makes the use of fully tempered and laminated safety glass compulsory in certain parts of car glazing.

1953

- Trosifol[®] PVB interlayer is registered as a product name in the commercial register by Dynamit Nobel company. It is based on the PVB polymer base Mowital[®] by the former German chemical company Hoechst AG.

1960s

- PVB interlayer starts to see use commercially in architectural glazing application. DuPont installs the first commercial film plant in Fayetteville/N.C.,USA.

1968

- Trosifol becomes the first manufacturer to replace the usual powdered PVB with the newly patented PE interleaving film, thus making washing and conditioning of the film superfluous.



• 1988: First Asean PVB film line in Ulsan, South Korea

1972

- The first commercial Trosifol[®] PVB film line in a width of 2.0 m (79") goes on stream.

1983

- Trosifol starts the 2nd film line in a maximum width of 3.21 m (126") to match the lamination process of jumbo sized float glass.

1988

- DuPont starts the first Asean PVB film line in Ulsan/ South Korea and another line in Hamm-Uentrop/Germany.

1992

- DuPont and AIA establish the Benedictus Awards to celebrate the innovative uses of laminated glass in international design and architecture.
- Trosifol starts the 3rd commercial film line in the width of 3.21 m (126") in Troisdorf/Germany.

1993

- DuPont starts the operation of a recycling PVB film line in Holosov/Czech Republik.

1998

- DuPont launches SentryGlas[®] Plus, a new ionoplast interlayer for high performance architectural application. Initially, it is predominantly used for hurricane resistant safety glazing application. The product receives its first Notice of Acceptance (NOA) from Miami Dade County in Florida/USA.

2000

- Market launch of the first patented acoustic PVB film Trosifol[®] Sound Control monolayer.

2001

- Start of the 3rd film line in the width of 3.21 m (126") in Troisdorf/Germany.

2002

- Trosifol[®] is certified to the global quality standard ISO/TS 16949.



2003: Film plant in Bor, Russia

2003

- Launch of the new automotive film Trosifol® VG. A new film plant in Bor, Russia is commissioned.

2004

- Launch of the first Trosifol® Solar PVB film for the encapsulation of solar cells in double glass PV modules.
- Acquisition of the Trosifol business from HT Troplast to the Japanese company Kuraray

2005

- DuPont launches SentryGlas® SGP 5000, a new and improved form of its predecessor SentryGlas® SGP 2000. Later this product is renamed as SentryGlas® (SG).

2006

- The new and improved PVB architectural glass film Trosifol® BG is launched. Trosifol's environmental management system is certified to EN ISO 14001.

2007

- Start of operation of the 4th PVB film line in width 3.21 m (126") in Troisdorf plant.

2010

- The newly developed acoustic Trosifol® SC+ trilayer film is launched for architectural glazing application.
- SentryGlas® claims significant share of the global architectural glass market for high-end structural glazing application. Beside the sheet delivery form this film is also available on rolls.

2013

- Kuraray starts the operation of the first film line dedicated to automotive application in a line width of 1.70 m (67") in Troisdorf plant.
- Launch of Trosifol® Extra Stiff (ES) for structural glazing application.

2014

- Kuraray acquires DuPont's GLS Division to form a large global safety glass interlayer manufacturer.

2016

- Kuraray launches SentryGlas® Translucent White to enlarge the variety of structural glazing application.
- Harmonization and re-branding of all globally offered PVB interlayer (incl. former Butacite® PVB and SentryGlas® ionoplast interlayer) under the new head brand name Trosifol.

2018

- Start of operation of the 2nd PVB automotive film line in Ulsan, South Korea.
- SentryGlas® trademark rights passed to Kuraray

2019

- Start of operation of a new SentryGlas® ionoplast film line in Holesov/Czech Republic (line width 2700 mm / 106 in).
- Launch of SentryGlas® Xtra™

2021

- Increase of line width for SentryGlas® and SentryGlas® Xtra™ in Holesov/Czech Republic to 3300 mm (130 in).



2014: Trosifol® production plant in Troisdorf, Germany



2019: Holesov, CZ



Chapter 2

Production and Logistics

2.1. Production of polyvinyl butyral resin

The long expertise of PVB interlayer technology is based on the captive production of special PVB resin or polymer for the latter processing of high class interlayers. It's a 3-stage chemical process in a water based polymerization and is shown in the following scheme:



3-Stage process for the production of polyvinyl butyral (PVB)

STAGE 1

Polyvinyl butyral is produced in a three-stage process via polyvinyl alcohol, starting with acetylene and acetic acid for the production of monomeric vinyl acetate:

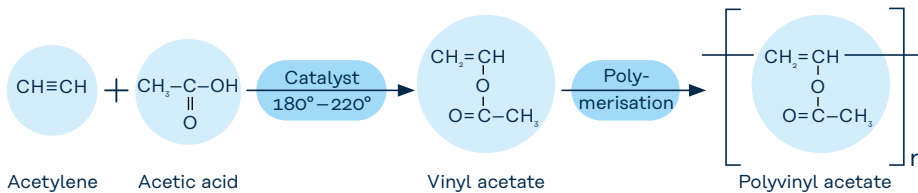

STAGE 2

Since monomeric vinyl alcohol is unstable as a free compound and is not available for polymerisation, polyvinyl acetate is converted by saponification in the presence of methanol into polyvinyl alcohol:

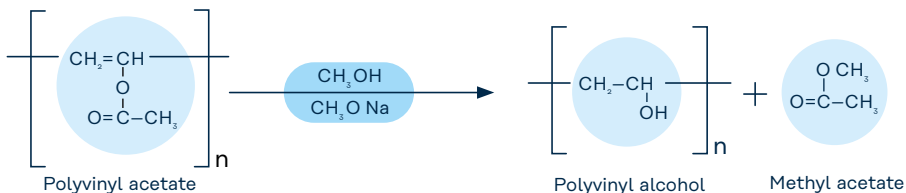

STAGE 3

Polyvinyl butyral is produced by acetalisation of the polyvinyl alcohol with butyraldehyde in an acidic medium:

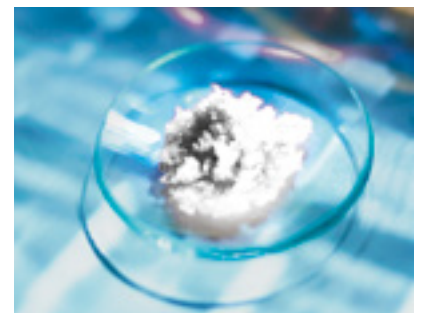
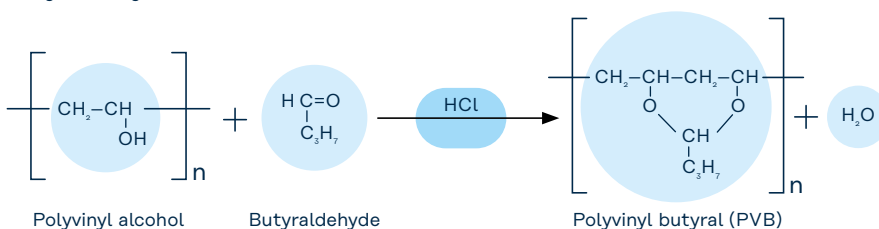

2.2. Raw materials for PVB film production



Polyvinyl butyral resin and plasticiser

The use of PVB resin as a laminated safety glass interlayer has a lot to do with its chemical composition and particularly with the number of free hydroxyl groups in the polymer chain. The PVB resin can be varied by modifying the molecular weight of the initial polyvinyl acetate, the degree of hydrolysis into polyvinyl alcohol and the amount of butyraldehyde used for acetalisation. Consequently, PVB can also be regarded as a terpolymer of vinyl acetate (x), vinyl alcohol (y) and vinyl butyral (z):

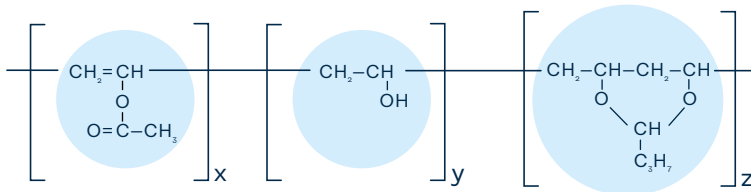

Other typical applications for PVB resins include their use in adhesives, coatings, paints, primers or printing inks. These polymer grades of PVB have a different chemical composition and molecular weight.

PVB resin is a white powder that is stiff in film form and does not have sufficient elasticity to be used as a film in laminated safety glass. Its compatibility with plasticizers depends primarily on the vinyl alcohol content of the polymer chain. Suitable plasticisers for PVB resin are e.g. esters of polyethylene glycol and aliphatic fatty acids (see below example/chemical formula). The type and quantity determine the properties of the film. The most important properties for the given application are the mechanical properties, cold-crack temperature, water-absorbency and the film's adhesion to glass. Other ingredients of PVB interlayers are polymer additives such as UV absorbers and/or pigments and dyes for coloration.

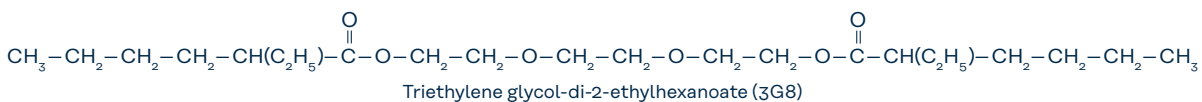

2.3. Trosifol® production

PVB interlayer production process

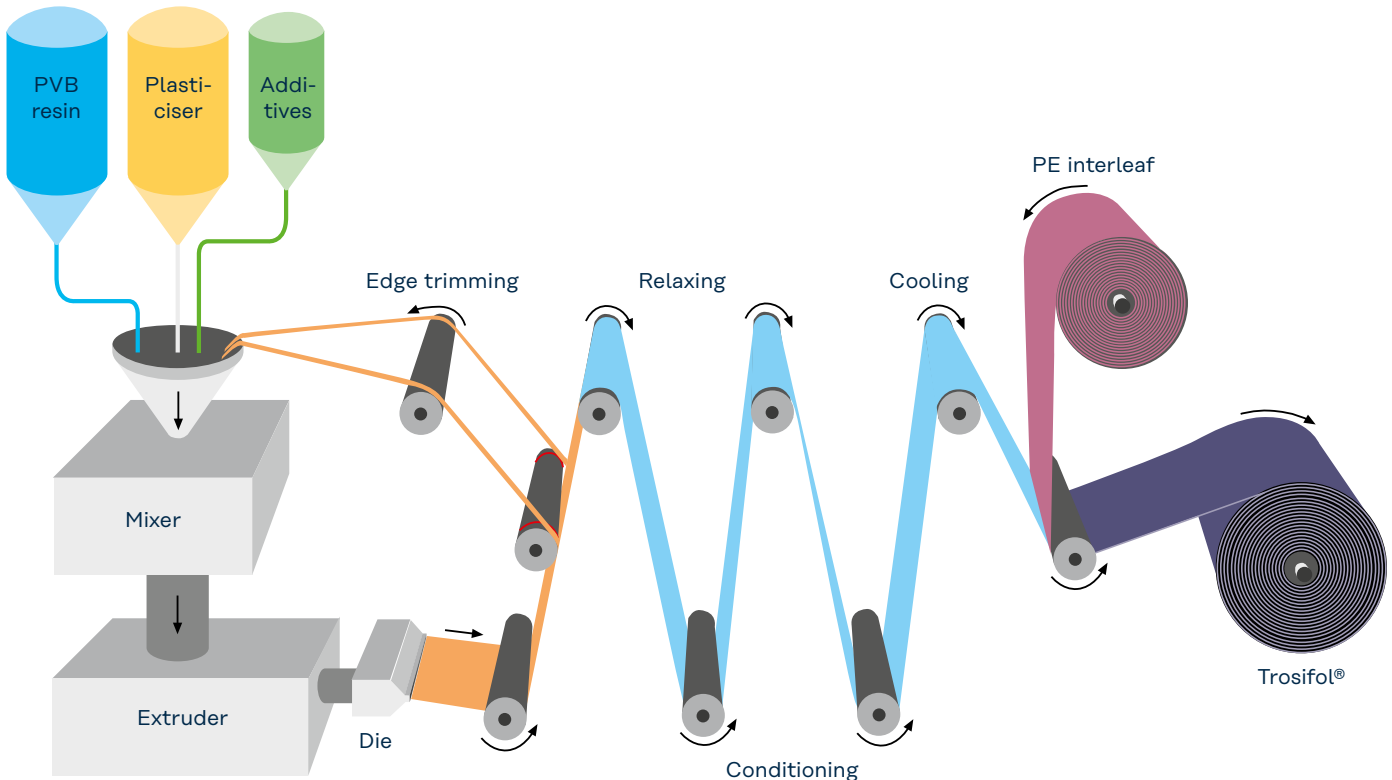

Production starts with the metering of PVB resin, plasticiser and additives into an extruder (see figure above), where all the components are thoroughly mixed and plasticised. Meticulous homogenisation is very important in this context because inhomogeneity can have a negative influence on the mechanical and optical properties of the product. Extrusion is performed through a broad nozzle, whereby special importance is attached to achieving a constant and precise thickness over the entire width. With a maximum width of 3300 mm (132") and a thickness of 0.38 mm (15 mil) to 2.28 mm (90 mil), 100ths of a millimetre can make a huge difference. Since totally smooth PVB films would be so strongly adhesive that they would almost be impossible to reposition once applied to the glass, a special surface finish is now applied to both sides of the Trosifol® film. Here, too, uniformity is absolutely necessary.

The film is then cut to the desired width, with edge trimmings being returned to the extrusion process. In a downstream section, the film is allowed to relax, i.e. internal stresses that would result in shrinkage during the assembly process are relieved. In a further section, the film's moisture content is adjusted to the required level. The film is then cooled to 8°C (46°F) and interleaved with a PE film if required. The film winding room is air-conditioned: firstly to make sure that the climate matches that of the customers assembly room and secondly to prevent changes in the

moisture content of the film. The rolls are immediately packed gas- and moisture-tight and pass a double lock on their way to the interlayer stock and transportation to the end user.



2.4. Trosifol® glass adhesion

Glass adhesion can be inhibited by water that has not been demineralised or is insufficiently purified. Mineral residues from hard water can then accumulate on the glass surface after drying. Organic residues, such as cutting oils or greases, also significantly affect adhesion between PVB and the glass surface.

Trosifol®'s adhesion to glass depends on the formation of hydrogen bridges between the water-compatible groups of the glass surface and those of the polymer.

Trosifol® adhesion to a clean glass surface

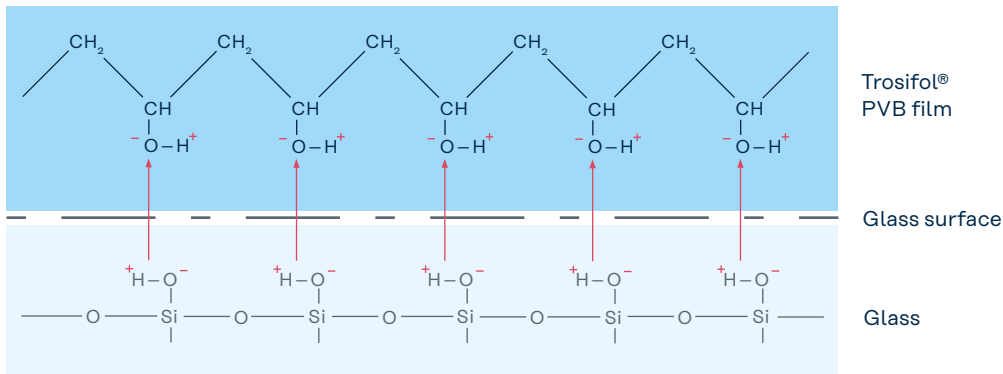

Clean glass surface + right film moisture content = good adhesion

Trosifol® adhesion to an unclean glass surface

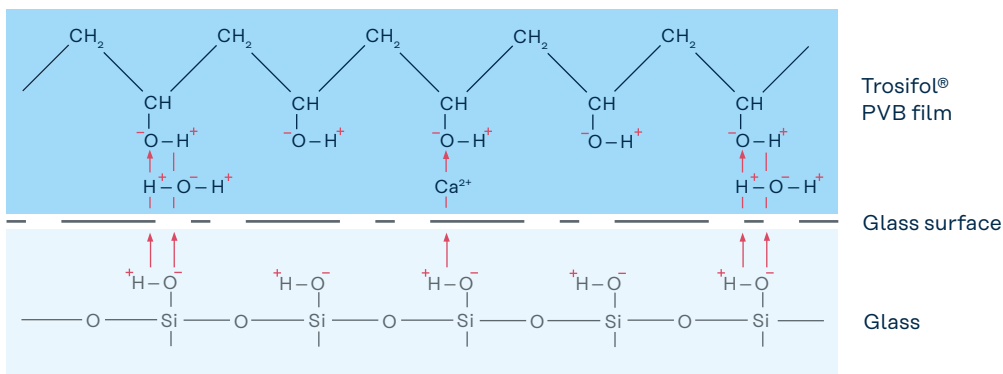

Unclean glass surface (e.g. mineral residue) or excessive film moisture content = poor adhesion

Unlike charges attract –
like charges repel.

Global architectural glazing standards require a specific breakage behavior when the glass is penetrated by external impact e.g. on a window pane in case of a burglary attempt. Originally designed in front glass car glazing of the 50ties in the last century, this principle was taken over to architectural laminated glass based on annealed glass in the 80ties.

To protect people against injury by sharp glass particles in case of glass destruction and to dissipate the energy by glass deformation, the glass adhesion of PVB has a big impact to the breakage behavior.

Glass breakage behaviour with high-adhesion PVB interlayers for optimum fragmentation

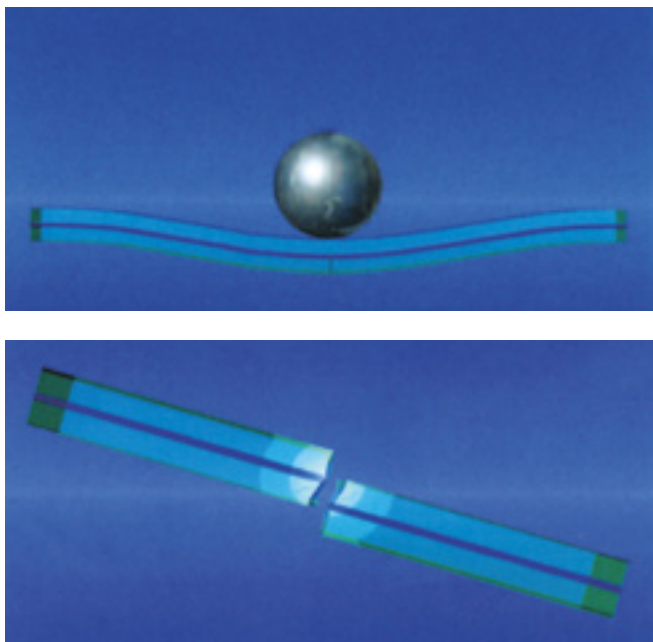

PVB films with controlled adhesion are employed in applications where the laminated safety glass has to meet high standards of impact resistance. Typical applications are windscreens in automotive glazing and windows and doors in architectural glazing. Such glazing has to meet the following requirements in terms of fragmentation behavior in an impact test:

It must not release injury-causing fragments upon glass fracture.

It must not allow impacting objects to penetrate the glass.

In other words, the film-to-glass adhesion must not be reduced to the point that the product ceases to qualify as laminated safety glass.

In case of replacement of annealed glass by tempered or heat-strengthened glass in the laminate the breakage behavior will be different caused by the glass strength and the type of impact. This can have an influence on the PVB glass adhesion, and in this case smaller particles after impact have to be held together due to changed residual load strength (see chapter 3).

Glass breakage behavior with reduced glass adhesion PVB film for optimized penetration resistance

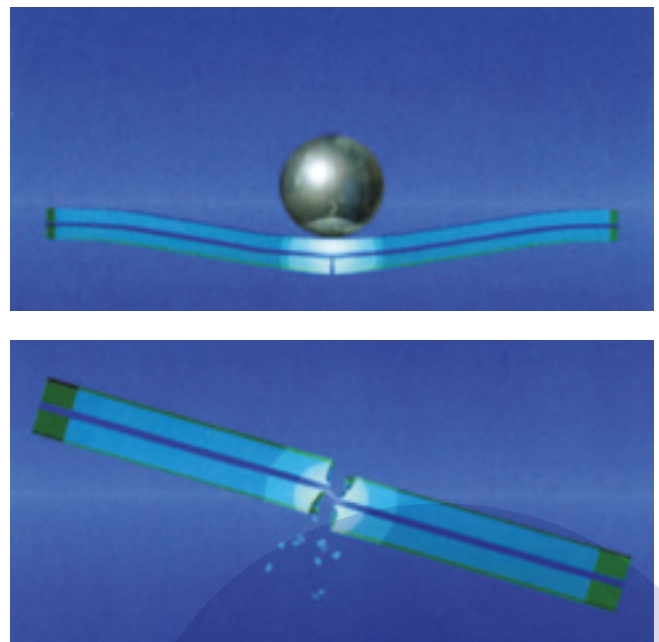

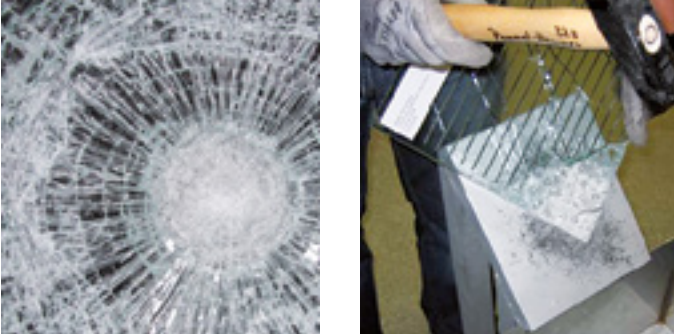

When laminated float glass assemblies are hit by a solid object, both glass plies will usually break, resulting in the formation of a spiders web fracture pattern with concentric circular cracking around the centre of impact and radial cracking extending from the centre into the surrounding glass area.

This way, small glass fragments still adhere to the Trosifol® PVB interlayer and do not cause a major injury hazard. Depending on the impact energy, laminated safety glass will bulge, i.e. undergo elastic deformation. This occurs when the Trosifol® interlayer is neither sheared nor cut by the sharp edges of the glass fragments, but becomes partly delaminated as a result of the controlled reduction in its adhesion. In this process, the Trosifol® film can stretch due to its elasticity, and the laminated safety glass will undergo elastic deformation within certain limits.

This characteristic explains the requirement that the Trosifol® interlayer used in laminated safety glass should be sufficiently elastic over a larger temperature range and should not be susceptible to brittle fracture at low and sub-zero temperatures.

Since the moisture content of a PVB film cannot be raised indefinitely, the necessary reduction in film adhesion cannot be achieved by varying the moisture content alone. Equally, the polyvinyl alcohol level can only be adjusted within narrow limits to vary the strength of film adhesion, since the latter, together with the type and quantity of the selected plasticiser, determines the film's mechanical properties. For this reason, the interlayer is formulated with special ingredients acting as adhesion-controlling additives.

Beside the water content and chemical adhesion control, the glass orientation in a laminate plays an important role: one can match Air/Air, Air/Tin and Tin/Tin lay-up in a glass sandwich. Typically the Air side yields in a higher value of glass adhesion than the Tin side, but this is mainly valid for annealed glass and may change by the use of tempered, heat strengthened or coated/printed glass.

Surface properties of the glass sides (comparison of different glass manufacturers)

Glass type 1
Tin side:

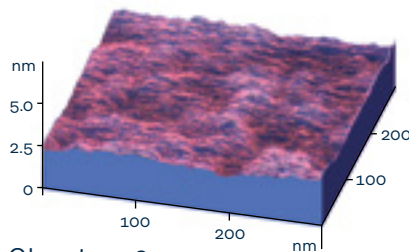

Glass type 1
Air side:

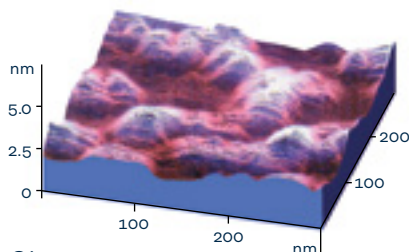

Glass type 2
Tin side:

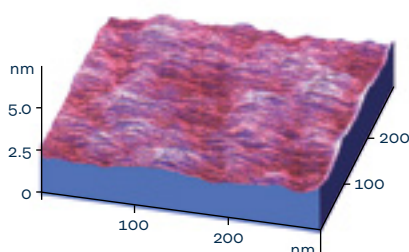

Glass type 2
Air side:

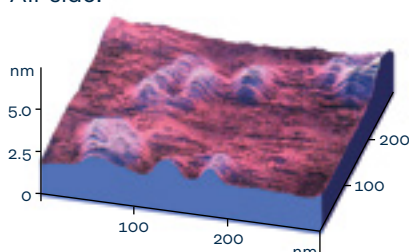

THE EFFECT OF THE GLASS

The illustrations show a comparison of the highly enlarged surfaces of both sides of two float glass products.

The differing surface roughnesses yield differing levels of mechanical interlocking between the film and the glass after the laminating process and hence different degrees of adhesion, measurable with various destructive tests on the glass assembly. If the glass is toughened or subsequently coated or printed, this post-treatment may modify the chemical nature of the glass surface.

To ensure optimised glass adhesion in such cases, Trosifol® films with defined degrees of adhesion are recommended.

2.5. Product dimensions

Trosifol® polyvinyl butyral and SentryGlas® ionoplast interlayers for architectural laminated safety glass are offered in a broad product range. They are divided into the following groups:

TROSIFOL® PVB INTERLAYER PRODUCT GROUPS FOR ARCHITECTURAL APPLICATION

- Safety Interlayers
- Decorative Interlayers
- Sound Control Interlayers
- Structural & Security Interlayers
- Specialized Interlayers



In the following tables one finds a list of the available products for each group, the product codes and the possible roll dimensions. All interlayers are available as refrigerated film or with Polyethylene interleaf (see also under pages 20 to 24).



More info under www.trosifol.com

Safety Interlayers – dimensions

Type	Adhesion	Film thickness		Roll widths*		Roll length refrigerated		Roll length PE interleaved	
		[mm]	[mil]	[mm]	[in]	[m]	[ft]	[m]	[ft]
Trosifol® Clear	medium	0.38	15	600-3300	24-130	500/1000	1640/3281	400	1312
Trosifol® Clear	low	0.76	30	600-3300	24-130	250/500	820/1640	250	820
Trosifol® Clear	medium	1.14	45	600-3300	24-130	150/330	492/1082	150	492
Trosifol® Clear	medium	1.52	60	600-3300	24-130	125/250	410/820	125	410
Trosifol® Clear	medium	2.28	90	600-3300	24-130	95/177	312/580	95	312
Trosifol® UltraClear	high	0.76	30	600-3300	24-130	250/500	820/1640	250	820
Trosifol® UltraClear	high	1.14	45	600-3300	24-130	150/330	492/1082	150	492
Trosifol® UltraClear	high	1.52	60	600-3300	24-130	125/250	410/820	125	410

TAB 1 • * Only available in standard width. Other sizes available on request with minimum order quantities and binding purchase commitment.

Structural & Security Interlayers* – dimensions for products on rolls

Type	Thickness		Color	Roll widths		Roll lengths	
	[mm]	[mil]		[mm]	[in]	[m]	[ft]
Trosifol® Extra Stiff	0.76	30	Clear	1000-3210	39-126	250	820
SentryGlas® / SGX™ *1	0.76	30	Clear	1050-3300*2	41-130*2	250	820
SentryGlas®	0.76	30	Clear	1220/1530/1830	48/60/72	200	656
SentryGlas®	0.76	30	Clear	1530	60	50	164
SentryGlas® / SGX™	0.76	30	Clear	1050-3300*2	41-130*2	60	197
SentryGlas® / SGX™	0.89	35	Clear	1220-3300*2	48-130*2	200	656
SentryGlas® / SGX™	0.89	35	Clear	1530-3300*2	60-130*2	50	164
SentryGlas® Translucent White	0.80	31	Transl. White	1220/1830 1530/3300	48/72 60/130	200 200/50	656 656/164

TAB 2 • *1 SGX™ = SentryGlas® Xtra™

*2 Only available in standard width. Other sizes available on request with minimum order quantities and binding purchase commitment.

Structural & Security Interlayers* – dimensions for sheet products

Type	Thickness		Sheet widths		Sheet lengths	
	[mm]	[mil]	[mm]	[in]	[m]	[ft]
SentryGlas®	0.89	35	610-2160*3	24-85*3	6	19
SentryGlas®	1.52	60	610-2160*3	24-85*3	6	19
SentryGlas®	2.28	90	610-2160*3	24-85*3	6	19
SentryGlas®	2.53	100	610-1830	24-72	6	19
SentryGlas®	3.04	120	610-1830	24-73	6	19
SentryGlas® Xtra™	0.89	35	610-2160*3	24-85*3	6	19
SentryGlas® Xtra™	1.52	60	610-2160*3	24-85*3	6	19
SentryGlas® Xtra™	2.28	90	610-2160*3	24-85*3	6	19
SentryGlas® Xtra™	2.53	100	610-2160*3	24-85*3	6	19

TAB 3 • *3 Oversize shipment possible up to 2500 mm / 99 inches

• * The table shows the global product program.
Not all products are available in all regions.

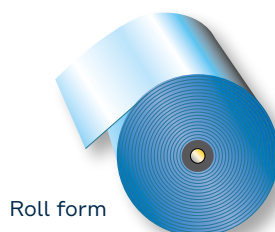

Roll form



Sheet form

Decorative Interlayers – dimensions

Product	Film thickness [mm]		Film thickness [mil]		Roll widths [mm]		Roll widths [in]		Roll lengths refrigerated [m]		Roll lengths refrigerated [ft]		Roll lengths PE interleaf [m]		Roll lengths PE interleaf [ft]	
Tints																
Trosifol® Light Blue-Green	0.38	0.76* ¹	15	30* ¹	1000-3210* ²		39-126* ²		400/500	200/250	1312/1640	656/250	400	200	1312	656
Trosifol® Bronze	0.76		30		1000-3210* ²		39-126* ²		200		656		200		656	
Trosifol® Medium Bronze	0.38* ¹		15* ¹		1000-3210* ²		39-126* ²		400		1312		400		1312	
Trosifol® Light Brown	0.38		15		1000-3210* ²		39-126* ²		400		1312		400		1312	
Trosifol® Medium Brown	0.38		15		1000-3210* ²		39-126* ²		400		1312		400		1312	
Trosifol® Grey	0.38	0.76	15	30	1000-3210* ²		39-126* ²		400/500	200/250	1312/1640	656/820	400	200	1312	656
Trosifol® Asahi Grey	0.38		15		1000-3210* ²		39-126* ²		400		1312		400		1312	
Trosifol® Solar Grey	0.76		30													
Black & White																
Trosifol® Brilliant Black	0.76		30		1000/1600/2250		39/63/88		–		–		60/250		197/820	
Trosifol® Diamond White	0.76		30		1000/1600/2250		39/63/88		–		–		60/250		197/820	
Trosifol® Shining White	0.38		15		1000/1600/2250		39/63/88		–		–		60/250		197/820	
Trosifol® Translucent White	0.38	0.76	15	30	1000-3210* ²		39-126* ²		400/1000	250/500	1312/3280	820/1640	400	200	1312	656
Trosifol® Translucent White (see on page 23)	0.76	high adhesion	30		1000-2400* ²		39-94* ²		–		–		250		820	
Trosifol® Sand White	0.38		15		1000-3210* ²		39-126* ²		400		1312		400		1312	
SentryGlas® Translucent White	0.80		31		1220-3300		48-126		–		–		200	200/50	656	656/164

TAB 4 • ¹ Product also available as 0.76 mm (30 mil) version with comparable optics and enhanced safety features
² Only available in standard width. Other sizes available on request with minimum order quantities and binding purchase commitment.
 Not all products are available in all regions.

Acoustic Interlayers – dimensions

Type	Film thickness		Roll widths		Roll length refrigerated		Roll length PE interleaved	
	[mm]	[mil]	[mm]	[in]	[m]	[ft]	[m]	[ft]
Trosifol® SC Monolayer	0.76	30	1000-3210*	39-126*	–	–	230/450	754/1476
Trosifol® SC Monolayer	1.52	60	1000-3210*	39-126*	–	–	100	328
Trosifol® SC Multilayer	0.50	20	3210	126	350/700	1148/2296	370/700	1214/2296
Trosifol® SC Multilayer	0.76	30	1000-3210*	39-126*	470	1542	230	754

TAB 5 • * Only available in standard width. Other sizes available on request with minimum order quantities and binding purchase commitment.
 Not all products are available in all regions.

Trosifol® Translucent White with a high-adhesion enlarges the product portfolio in the area of decorative colored films. Launched in 2021, the product is available in 0.76 mm (30 mil) thickness and in roll lengths of 250 m (820 ft).

The product has the same optical properties as Trosifol's existing Translucent White. As with all Trosifol® Translucent White products, however, the manufacturer recommends only processing films from one batch within a project in order to ensure consistent quality.



Photo: © Kuraray

• New Headquarters Building, Seattle, USA

Specialized Interlayers – dimensions for products on rolls

Type	Thickness		Roll widths [mm]	Roll widths [in]	Roll lengths	
	[mm]	[mil]			[m]	[ft]
Trosifol® HR	0.76	30	1000-3210	39-126	200	656
Trosifol® UV Extra Protect	0.76	30	1000-3210	39-126	50/200	164/656
Trosifol® Natural UV	0.76	30	1000-3210	39-126	250	820
Trosifol® XT UltraClear	2.28	90	1000-3210	39-126	95	312
SentryGlas® Natural UV	0.89	35	1220/1530/1830/3300	48/60/72/130	50/200	164/656
SentryGlas® Natural UV	1.52*2	60*2	–	–	–	–
Trosifol® Spallshield® CPET	0.18	7	1530	60	50/250	164/820
Trosifol® PET	0.18	7	1530	60	1325	4347

TAB 6 • *2 SentryGlas® Natural UV 1.52 mm (60 mil) is only available in sheets. Same sizes as standard SG sheets.

Not all products are available in all regions.

2.6. Packaging type

2.6.1. PACKAGING MULTI-WAY¹

Multi-way packages - horizontal

Max. roll width [mm]	Type 1 dimensions [mm]:			Weight [kg]
	Length	Width	Height	
800	1020	595	805	71
1240	1420	595	805	85
1600	1800	595	805	155
2000	2160	595	805	168
2250	2480	595	805	199
2650	2830	595	805	202
3210	3400	595	805	230
3210 (Jumbo size)	3400	780	985	230

TAB 7 •



Multi-way packages – horizontal with blanket (Type 1)

Multi-way packages - vertical

Max. roll width [mm]	Dimensions [mm]:		Weight [kg]	Maximum stacking height*
	Length	Width		
1300	1500	872	135	3
1300	1310	1200	151	3
1240	870	–	149	2

TAB 8 •



Multi-way packages – vertical 2 Rolls



Multi-way packages – vertical 4 Rolls

• ¹ Packages by site/product can vary, for the same or similar sized rolls.

* The maximum stacking height applies only to full pallets.

2.6.2. PACKAGING ONE-WAY¹

One-way packages - horizontal

Max. roll width [mm]	Dimensions [mm]:			Weight [kg]	Maximum stacking height*
	Length	Width	Height		
860	1000	595	740	23	4
1000	1130	595	740	30	4
1320	1420	595	740	34	4
1500	1620	595	740	41	4
1850	2070	595	740	47	4
2160	2240	595	740	51	4
2600	2710	595	740	73	4
3210 (Jumbo size)	3400	595	740	85	4
1100**	1250	330 370 ²	530	48	4
1600**	1750	330 370 ²	530	24	4
2250**	2410	330 370 ²	530	33	4
3210**	3400	330 370 ²	530	43	4

TAB 9 •



One-way packages – horizontal



One-way packages - vertical (4 Rolls per pallet)

Max. roll width [mm]	Dimensions [mm]:			Weight [kg]	Maximum stacking height*
	Length	Width	Height		
700	1130	1130	910	59	4
800	1130	1130	1010	60	4
950	1130	1130	1160	63	3
1120	1130	1130	1330	65	3
1330	1130	1130	1500	68	3

TAB 10 •



One-way packages – vertical

• ¹ Packages by site/product can vary, for the same or similar sized rolls.

² 370 = sample rolls only

* The maximum stacking height applies only to full pallets.

** Color and all sample rolls

One-way wodden packages - vertical (2 Rolls per pallet)

Designation	Dimensions [mm]:			Weight [kg]	Packaging group
	Length	Width	Height		
4s plywood standing	1130	1130	910	59	WT4
4s plywood standing	1130	1130	1010	60	WT4
4s plywood standing	1130	1130	1160	63	WT4
4s plywood standing	1130	1130	1330	65	WT4

TAB 11 •

2.6.3. HOW TO FOLD UP REUSABLE PACKAGES (METAL)

They're easy to fold up. First release the two ends and slide them into the base of the pallet (Figure 1).

Then lift the sides and fold them in (Figures 2-5).
That's all there is to it!



2.6.4. HOW TO FOLD UP ONE-WAY PACKAGES (WOOD)

These packages are also quickly folded up. Lift the lid (Figure 1), collapse the rest (Figure 2) and lay flat on the pallet (Figure 3).

The next pallet can now be laid on top (Figure 4).



VERY IMPORTANT

- Please send us all packages folded in the manner described above. In their folded state, the pallets take up much less space in the truck and the shipper can use the extra space for further goods.
- If the pallets are not returned in their folded state, we are charged extra for shipment, and we may have to pass on these charges to you.
- We're therefore appealing to you to send the pallets back in their folded state. You'll see that folding the pallets takes just a moment.
- Polystyrene and the aluminium/PE bags from our deliveries can be put into a crate that hasn't been folded up and of course returned to us.

Thank you!



2.7. SentryGlas® packaging

Kuraray offers SentryGlas® interlayer both as sheets that are packed horizontally on a pallet (Figure 1) and in roll form (Figure 2). Both come hermetically sealed in foil bags to protect the sheets from moisture and contamination. The foil package is encased in cardboard to prevent damage that can occur during shipping.



➔ SentryGlas® sheet package on pallet



➔ SentryGlas® interlayer roll package on pallet

2.8. Product labels

Product label Trosifol®

External label



Order code

Roll number

Product name

0,76 mm 0,03 in

Thickness

Length

500 m 1640 ft

Width

Color

CLEAR

0,50 %

Moisture content

Shelf life

23/05

Internal label



Delivery form (refrigerated)

The design of the label can vary, depending on the production site.

Product label SentryGlas®

External label



Photo: © Kuraray

Internal label



Photo: © Kuraray

2.9. Delivery form

Trosifol® Architecture

Since Trosifol® PVB interlayer is fundamentally a thermoplastic adhesive with hygroscopic properties, some specific precautions have to be made to ensure uniform product performance and later high quality glass laminates. The effect of sticking two layers of film on the roll in spite of the film roughness on both sides is known as blocking. Due to the physical behavior of PVB this effect is temperature dependent and happens typically above 12 °C (54 °F). Various measures can be taken to prevent blocking and the associated impossibility of processing the PVB film.

One possible delivery form is to wind PVB as refrigerated film at 8 °C (46 °F) or below in the film line, to seal, store and transport the rolls at the same constant temperature. Only this procedure ensures safe and trouble free handling. Upon arrival at the laminator, the packages should immediately be moved into a cold storage area or refrigerated warehouse and maintained at the above mentioned temperature. However, this method consumes a large amount of energy and therefore is cost-intensive.

The other possibility is to wind on an appropriate plastic separating film – in this case a thin embossed Polyethylene (PE) interleaving film. This process was developed and patented by Trosifol more than 40 years ago and finds a widespread use to this day. It makes handling easier and more cost effective.

Supplied in its original film packaging - independent of the delivery form - the user of PVB film must not open it before it is stored in a humidity controlled storage and processing room. Each Trosifol® roll is sealed in an aluminum foil bag to maintain a controlled moisture content at any ambient humidity level.

If a package should be damaged by crushing or tearing during transportation or improper handling during internal material movement, the roll has to be directly brought into a humidity and temperature controlled room to avoid unwanted moisture pick-up. In this case the already moistened outer layer should be unwound before use and dried separately.



Photo: © Benteler Maschinenbau GmbH & Co. KG



Photo: © Kuraray

2.9.1. TROSIFOL® WITH PE INTERLEAF

The unwanted adhesion of the Trosifol® film surface to itself is prevented by interleaving the individual Trosifol® layers with an embossed PE film. In its original packaging, Trosifol® with a PE interleaf can be stored in any normal, dry room. Trosifol® with a PE interleaf in its original heat-sealed PE bags has an usual storage life of at least four years without loss of quality. However, Trosifol® with a PE interleaf in its factory-sealed packaging should not be stored at temperatures in excess of 30 °C (86 °F). It is also possible to keep the rolls in a refrigerated film store at a temperature of approx. 8 °C (46 °F). Rolls that have been opened and partly used may be stored in a humidity controlled assembly room. This is particularly advantageous when small numbers of windshields of frequently changing types have to be produced or when, in the production of flat laminated glass for architectural applications, the sizes are such that a full Trosifol® roll cannot be used up at once.

Trosifol supplies its PVB film with or without a PE interleaf, with the PE interleaf being inserted during the winding process in film production. This method excludes the subsequent contamination of the film due to rewinding.

During winding and unwinding, care must be taken that subsequent contamination due to electrostatic charging cannot occur. This can be excluded by using static eliminators or ionised air in the winding area, for example. Prolonged direct contact between the PVB film and the anti-static equipment should be avoided because of the risk of film discoloration.

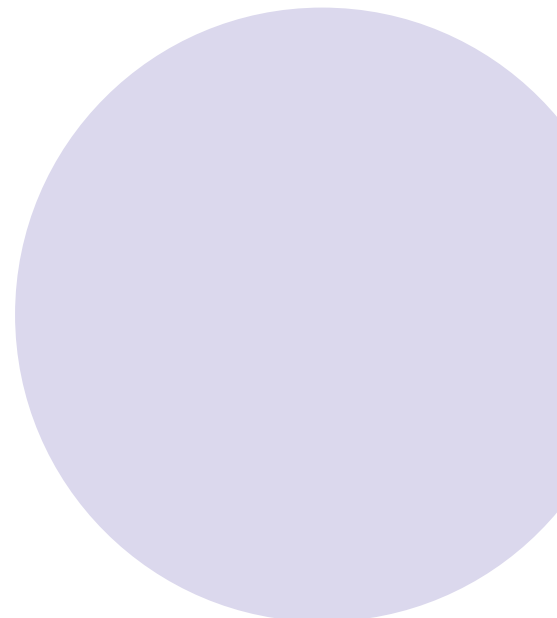

TROSIFOL® WITH A PE INTERLEAF

- Storage in a packed state without humidity control at maximum 30°C (86°F)
- Simple storage of partly used rolls in humidity controlled assembly rooms with frequently changing glass sizes
- Blocking not possible



Photo: © Bystronic glass

2.9.2. TROSIFOL® AS REFRIGERATED FILM

When PVB is wound up, stored or transported at temperatures $\leq 8^\circ\text{C}$ ($\leq 46^\circ\text{F}$), there is no need to use a separating agent to keep the layers of film apart on the roll. This property is exploited by Trosifol® refrigerated film that is transported in special refrigerated trucks. Trosifol® refrigerated film is stored in the original package at $\leq 8^\circ\text{C}$ ($\leq 46^\circ\text{F}$), usually in uncontrolled humidity conditions. Refrigerated film rolls stored for extended periods at temperatures of $> 8^\circ\text{C}$ ($> 46^\circ\text{F}$) often cannot be unwound without damaging the

film. Even renewed cooling to low temperatures still does not ensure damage-free separation of the film layers that have stuck together. When stored at 8°C (46°F) or higher in the assembly room, the refrigerated film rolls must be completely unwound, and processed or cut to size within 2-3 hours.



All refrigerated PVB interlayers have a frost star on their labels.

Trosifol® with a PE interleaf and Trosifol® refrigerated film only differ in their delivery form and not in the film composition. Consequently, the procedure only differs in the preparation of the film and not in the actual laminating process. Compared with refrigerated film, Trosifol® with a PE interleaf offers the advantage of the possibility of storing opened rolls in humidity controlled lamination rooms. Refrigerated film rolls have to be unwound and used or cut to size before they warm up. Trosifol® with a PE interleaf, which is no longer in its factory packaging, can be stored in an air-conditioned room at 18 to 20°C (64 to 68°F) and 25 to 30% relative humidity without the individual film layers sticking together and without any change in the previously set film moisture content of approx. 0.45%. An excessively moist film can be reconditioned at 25 to 30% relative humidity prior to processing. Such conditions restore the moisture content of approx. 0.4 to 0.5% required for processing. The film should be freely suspended for reconditioning, either cut to size or as a film strip. Subsequent reconditioning on the roll or in a film stack is not possible or would take a very long time.

Moisture diffusion speed at 20°C (68°F) and 60% relative humidity

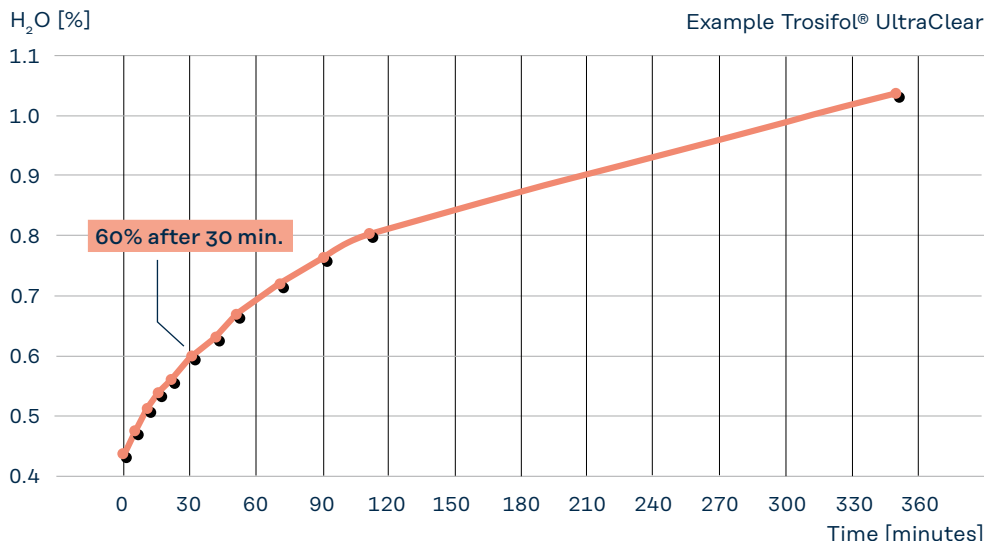

TROSIFOL® AS A REFRIGERATED FILM/ WITHOUT PE INTERLEAF

- Storage and transport refrigerated at $\leq 8^{\circ}\text{C}$ ($\leq 46^{\circ}\text{F}$), goal in USA: 2°C (35°F), in Asia 10°C (50°F)
- Storage of partly used rolls
 - Tightly sealed bag at $\leq 8^{\circ}\text{C}$ ($\leq 46^{\circ}\text{F}$) without controlled room humidity level
 - Open bag at $\leq 8^{\circ}\text{C}$ ($\leq 46^{\circ}\text{F}$) and 25 to 30 % relative humidity
- No PE to dispose of

> The film quality is the same for both delivery forms!



2.10. Trosifol® roll length calculation

Trosifol® roll leftovers as a refrigerated film (RF)

cm on the core	RF 0.76 mm (30 mil)
0	0
1	7
2	14
3	23
4	33
5	45
6	54
7	66
8	77
9	90
10	105
12	136
14	172
16	210
18	253
20	298
22	346
24	400
26	456
28	511

TAB 12 •

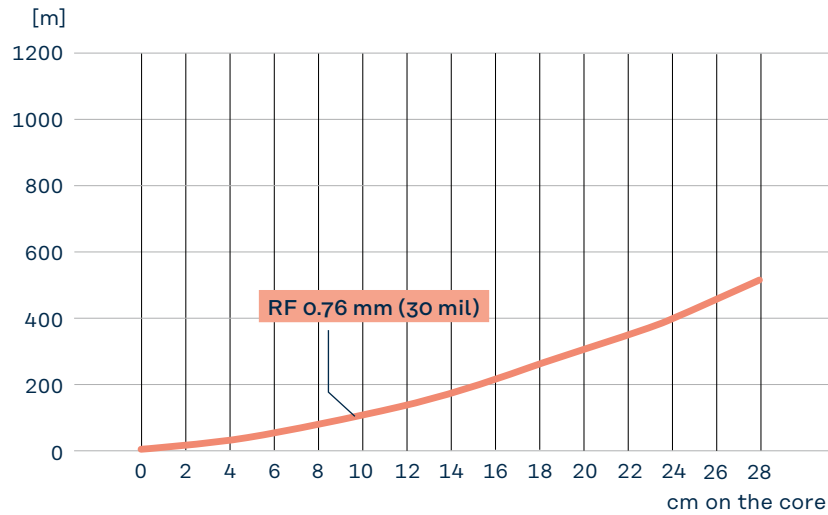

Trosifol® roll leftovers with a PE interleaf (PE)

cm on the core	PE 0.76 mm (30 mil)
0	0
1	5
2	10
3	20
4	30
5	40
6	50
7	60
8	80
9	90
10	100
12	130
14	160
16	200
18	240
20	270

TAB 13 •

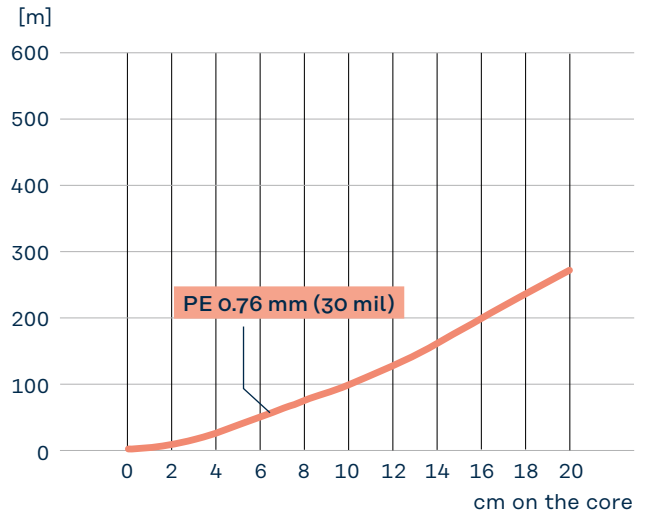

• These figures are guide values.
Core inner diameter = 154 -0/+2 mm



Photo © Bork/shutterstock.com

Chapter 3

Glass production

3.1. Glass production / glass types

The industrial mass production of basic float (or annealed) glass began in the 1950s with the process developed by A. Pilkington in Great Britain.

The raw materials of sand, soda, limestone etc. are mixed in a batch process and become molten in a furnace preheated up to 1500 °C (2,732 °F). Once molten, the temperature is gradually reduced over 1100 °C to 600 °C (2,012 °F to 1,112 °F) during the flow over a molten tin bath. Once off the bath, the glass sheets are cooled down gradually so that they anneal without strain. At the end of the line the cold glass is cut, stacked, stored and transported for further use.

Production of float glass

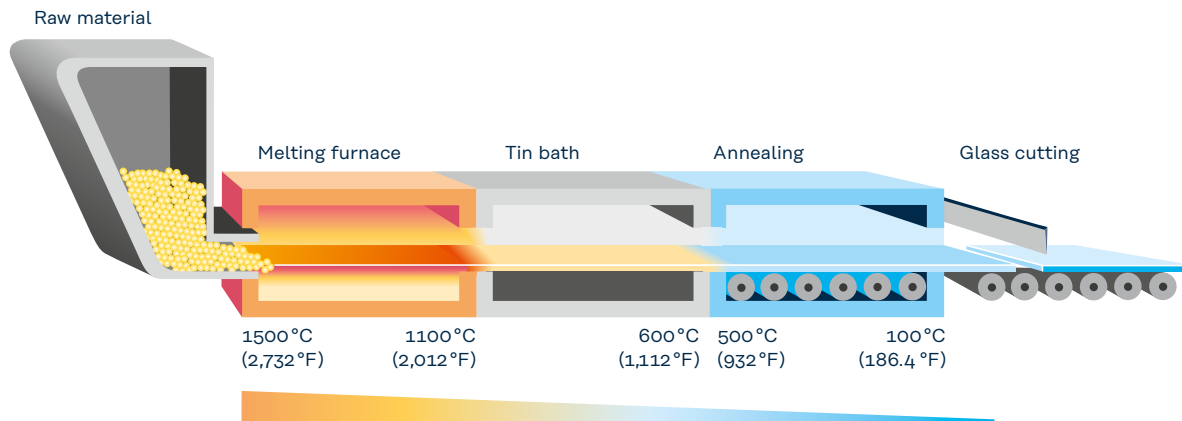

FLOAT / ANNEALED GLASS CHARACTERISTICS

- Low bending tensile strength
- Shatters into large, sharp-edged fragments
- Produced in widths of 3210 mm (126") and lengths of up to 15 m (591") (standard 6.0 (236") or 9.0 m (354") ribbon length)
- Available in thicknesses of 1.5 mm (59 mil) to 19 mm (748 mil) (in individual cases up to 25 mm (984 mil))
- Clear, tinted or extra clear (low iron) glass
- uncoated / coated

Technical characteristic values of float/annealed glass

Property	Symbol	Numerical value and unit
Density (at 18 °C / 64 °F)	ρ	2,500 kg/m ³
Hardness		6 units (acc. to Mohs)
Modulus of elasticity	E	7×10^{10} Pa
Poisson's ratio	μ	0.2
Specific heat capacity	c	0.72×10^3 J/(kg x K)
Mean coefficient of linear thermal expansion between 20 and 300 °C (68 and 572 °F)	α	9×10^{-6} /K
Thermal conductivity	λ	1 W/(mK)
Mean refractive index in the visible range (380 to 780 nm)	n	1.5
Softening temperature		approx. 600 °C (1,112 °F)

3.2. Fully tempered and heat-strengthened glass

Annealed glass alone is not safe due to its high brittleness and low internal stress which creates sharp pieces when destroyed by external impact. This effect played an important role in the impact resistance of thin vehicle glazing, but was more and more adapted in the architectural glass industry beginning from the end of the last century.

As alternative tempered or toughened glass was developed as a high safety class option. It is processed in a tempering furnace by controlled thermal treatment to increase its internal stress. This stress increases the strength compared with normal glass and cause it to crumble into granular, less hazardous pieces when broken. It also increases the thermal resistance vs. annealed glass.

HEAT-STRENGTHENED GLASS CHARACTERISTICS

- Production similar to tempered glass (except for the duration of the cooling process)
- Medium bending tensile strength
- Breaks into larger fragments than fully tempered glass when bending tensile strength is exceeded
- Heat-strengthened glass conforms to EN 1863 and/or ASTM C 1048.

FULLY TEMPERED GLASS CHARACTERISTICS

- Production in a tempering furnace at 600 to 700 °C (1,112 to 1,292 °F) with finished dimensions, edge pre-treatment and, if necessary, with drilled holes
- High bending tensile strength (to EN 12150)
- Breaks into small pieces when bending tensile strength is exceeded
- Fully tempered glass conforms to EN 12150 and/or ASTM C 1048.

Production of fully tempered and heat-strengthened glass

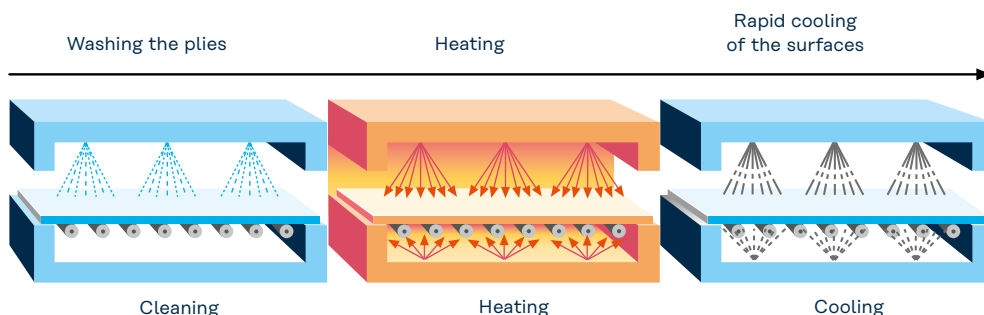



• Comparison fracturing of annealed, tempered (or heat-strengthened) glass vs. laminated glass made of annealed glass

Bending strength of different glass types according their corresponding European product standards

Glass type Property	Annealed glass EN 572-9 [N/mm ²]	Heat-strengthened glass EN 1863-1 [N/mm ²]	Thermally toughened glass EN 12150-1 [N/mm ²]	Heat soaked thermally toughened glass EN 14179-1 [N/mm ²]	Chemically strengthened glass EN 12337-1 [N/mm ²]
Minimum value mechanical strength*	45	70	120	120	150
Enamelled	–	45	75	75	–

TAB 15 • *Determined according the test method described in EN 1288-3

Another way to increase glass strength beside a thermal treatment is chemically strengthened glass. It is a result of a post-production chemical process.

The glass is submersed in a molten potassium salt at 300 °C / 572 °F. This causes sodium in the glass to be replaced by potassium ions from the bath solution. This brings the glass to a surface compression thus increasing the strength.

CHEMICALLY STRENGTHENED GLASS CHARACTERISTICS

- For chemical strengthening, the glass is immersed in a potassium nitrate bath.
- Defined in ASTM C1422 and DIN EN 12337
- Chemically treated glass is stronger than thermally tempered glass.

3.3. Flatness of tempered and heat strengthened glass

In the tempering process, the glass loses its high flatness. This is measured in accordance with EN 12150-1 (2015) and EN 1863.

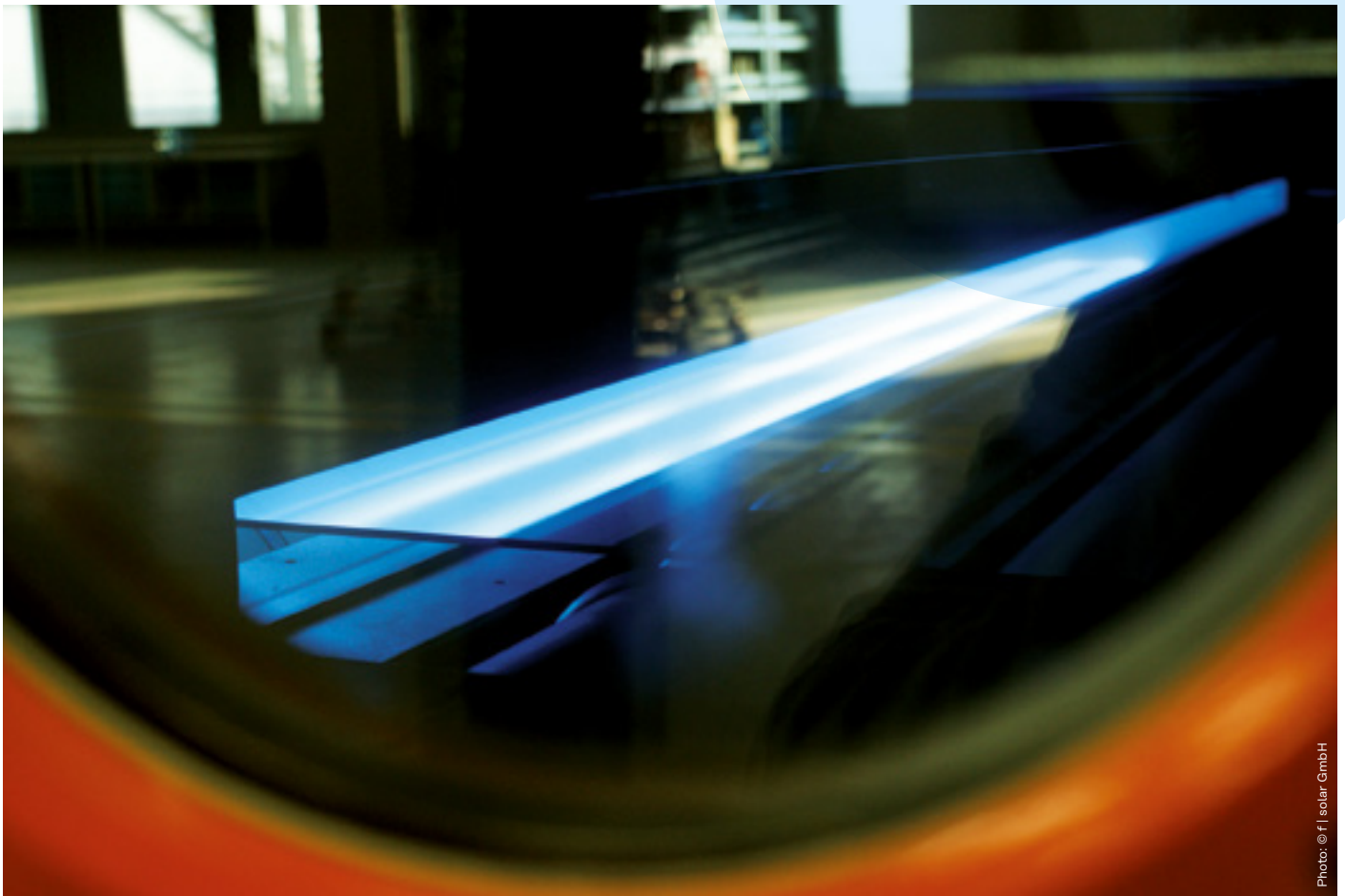

3.4. Post treatment of annealed glass

The following float glass treatment processes can be carried out before lamination into safety glass. Selected glass treatment processes are described in more detail on the following pages.

TREATMENT METHODS

- Cutting the glass to size (scoring, breaking, water-jet and laser cutting)
- Edge finishing (trimming, grinding, polishing)
- Drilling (water-jet and diamond)
- Glass coating (chemical/physical)
- Glass etching (chemical/etching, mechanical removal)
- Glass bending (gravity bending, press bending)
- Glass washing (by brushing/mechanical, spraying)

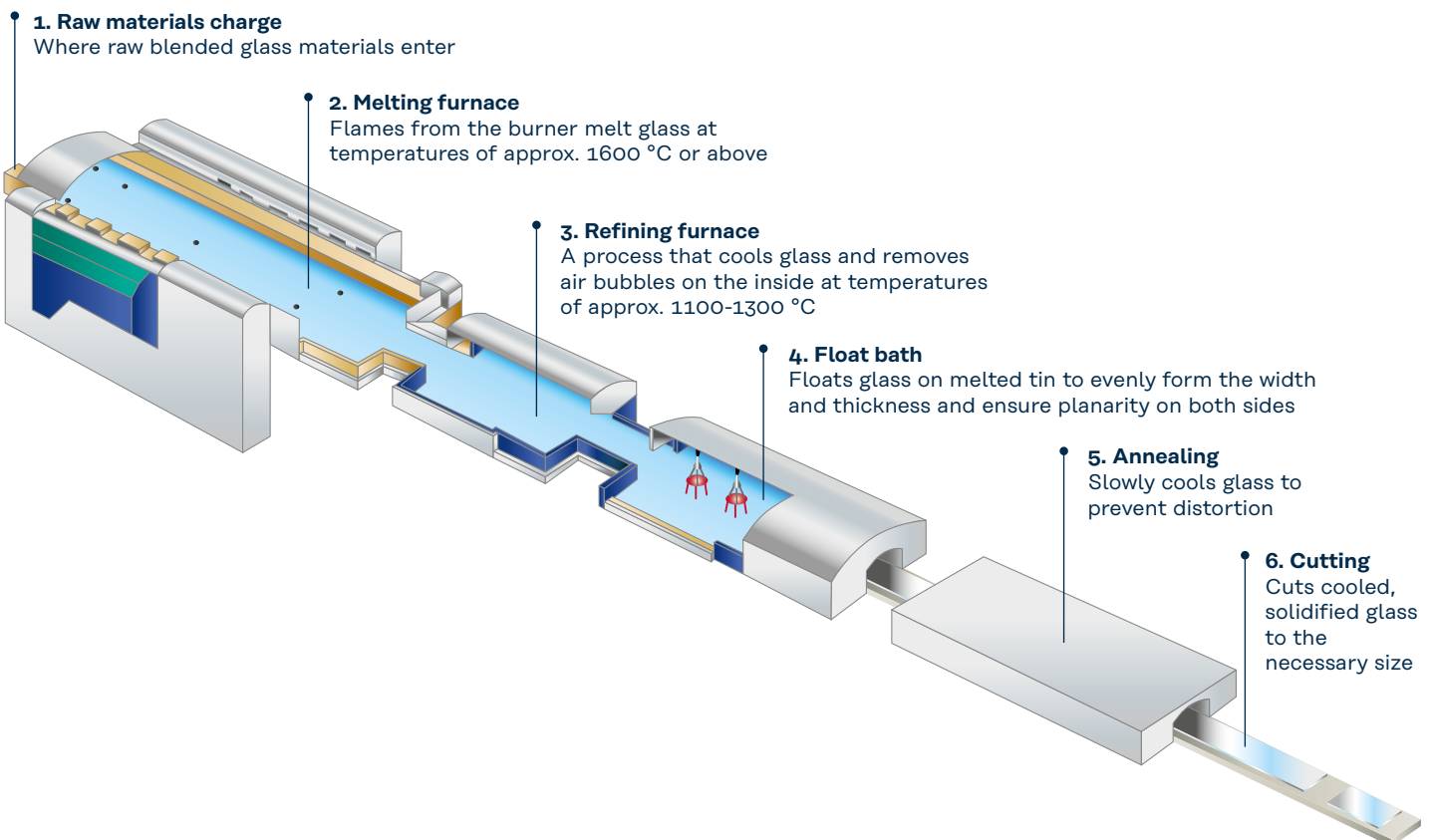

3.5. Glass coating

A considerable proportion of glass produced worldwide is processed into "low-E" (low emissivity) glass to improve the energy efficiency of architectural glazing. There are a large number of coating processes yielding glass with a broad range of applications. The two basic methods for the production of low-E glass are pyrolytic separation or online coating and the sputter process or offline coating.

3.5.1. ONLINE COATING

A metal oxide is coated onto the hot glass surface during the float glass production process, thereby establishing a tight bond with the glass. Glass coated in this way (hard coating) reflects the incoming visible and near-infrared light and can serve as thermal insulation. The surface strength of this coating is roughly as high as that of a glass surface. Glass coated in this way can be toughened as well as – depending on the glass maker's recommendation – laminated into safety glass with PVB film.

3.5.2. OFFLINE COATING

After the glass has been produced and cut to size, a cathode-ray process (sputtering) or some other vapour deposition technique applies layers of metals and metal oxides onto the glass in a vacuum. The particles are uniformly deposited on the glass surface in a continuous process.

This soft coating is more or less durable, depending on the type of metal oxides used. After this they have to be installed, for example, in insulation glazing or – if recommended by the manufacturer – laminated into safety glass, as they otherwise corrode. Within the given storage time, these films can be cleaned in suitable washing systems without damaging the glass.

This is where various metals and metal oxides, in some cases in complex compositions, are deposited on a glass surface, sealed with a cover layer and then laminated with an uncoated glass and PVB.

Because of the high corrosion sensitivity of these layers, they are removed from the edges of the glass as protection from moisture penetration and possibly edge-sealed.

Kuraray always recommends checking the adhesion and compatibility of the coatings with our products beforehand.

To select suitable and Kuraray PVB-compatible edge-sealing materials, please contact Trosifol® and SentryGlas® Technical Service.

3.6. Glass bending

Glass bending exploits the fact that glass has not a melting point but a softening range at around 650 °C / 1,112 °F. The glass plies are laid on prefabricated moulds covered with refractory textiles and then bent. While hand-made moulds are mainly used for architectural glass where quantities and shapes can vary widely, extreme simplification and automation have been achieved in the production of glass for motor vehicles where almost all panes are curved. The costly making of moulds is computer-controlled. A distinction is made between gravity bending and press bending.

3.6.1. GRAVITY BENDING

For gravity bending, the plies are bent in pairs with release agent in the bending mould at temperatures of over 600 °C / 1,102 °F. The thickness of the glass, size of the glass, bending radius and possible combinations of glass can affect the bending process and hence tolerances; these usually range from 2 to 7 mm. For thinner bended glass as used in curved automotive glazing, cycle times of the order of 20 s per glass pair can be achieved at approx. 650 °C / 1,112 °F in a continuous process with the furnaces heated electrically or with gas flames. Another possibility is to use box moulds that are fed through the pre-heating, bending and cooling zones. The advantages of this method are the programmability of the bending process, the use of different windscreen models in a box, and rapid and flexible model changing. Problems can arise with gravity bending due to the forced shaping, incorrect alignment or deformation of one of the two plies, and waviness during the cooling process. All these factors have an impact on the bending geometry, appearance and laminability of the glass.



Photo: © Glasperlmair

3.6.2. PRESS BENDING

In the press bending process, the plies are individually raised to a bending temperature of approx. 650 °C / 1,112 °F and then pressed into the mould. The temperature, pressure and bending time must be precisely controlled. The advantages of press bending include high cycle times, the bending of complex ply geometries, and the efficient handling of very thin glass. As with gravity bending, a clean, temperature-controlled cooling process is essential after bending in order to prevent the (unwanted) toughening of the plies.

If the glass is not washed after bending and the surfaces are only blown or vacuum-cleaned, any unremoved release agent may impair adhesion between the PVB and the glass.

The quality requirements for curved (and optionally toughened) glass are covered by ISO 11485-2 (2011). Laminated safety glass with spherically curved plies is subject to high dimensional tolerances; if additionally toughened, the waviness of the glass has to be limited in order to ensure a trouble-free laminating process and high optical quality of the finished product.



Chapter 4

Processing of architectural laminated safety glass

4.1. Introduction / basics

For the processing of laminated safety glass two or more glass plies are paired with one or more layers of Trosifol® PVB and SentryGlas® ionoplast interlayer sheets. This composition is called a glass sandwich. Under impact of energy and pressure this sandwich is bond yielding in the final laminate.

THE LAMINATING PROCESS CONSISTS OF THE FOLLOWING STEPS

- Glass pre-processing (see chapter 3)
- Glass washing / cleaning
- Assembly and film cutting (trimming)
- Heating and pressing (de-airing)
- Autoclaving
- Post treatment and quality control

Factors affecting LSG Production

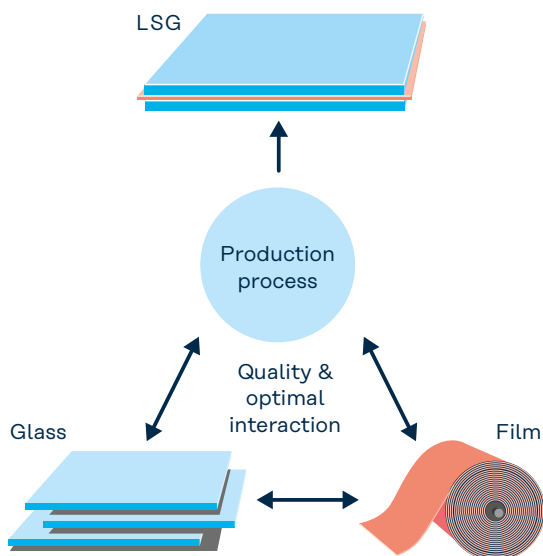

Each of these steps has a big influence on the quality of the final products. The following flow chart and graph show the different steps in more detail.

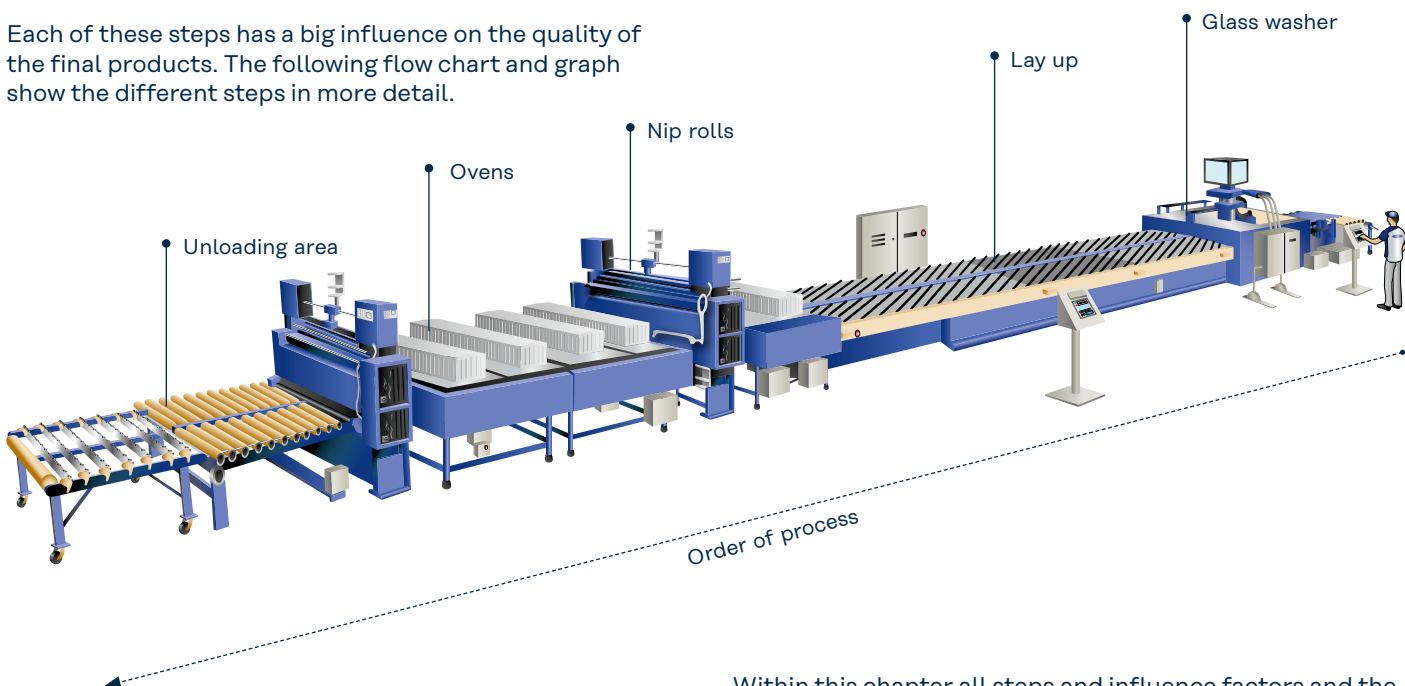

Within this chapter all steps and influence factors and the product quality will be described in more detail. It is based on the long term experience of the Trosifol technical staff as well as on laminators daily practice. It focusses on the PVB product family; in a later part of this book (Chapter 8.4.) the differences of SentryGlas® Ionoplast lamination process to Trosifol® PVB will be explained.

Flow diagram LSG process

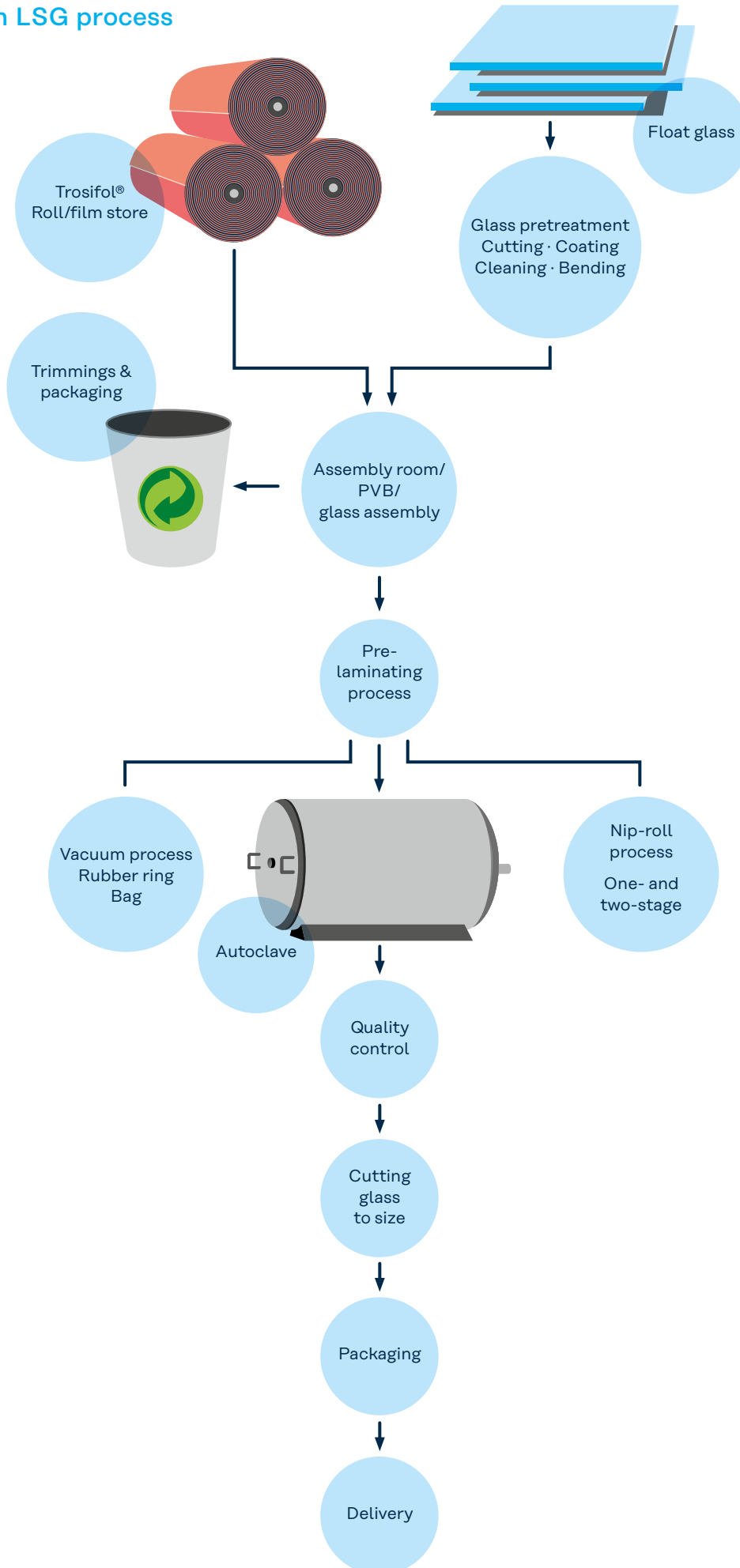

4.2. Glass preparation and cleaning

The annealed glass plies must be prepared with maximum care since their condition is crucial for the quality of the finished laminate. For the production of flat laminated safety glass, the individual glass plies are cut to their exact size from the stock glass. A clean cut must be produced because even fine micro-cracking at the edges can be the cause of glass breakage during laminate production. Should such defects occur relatively frequently during the production process, it is advisable to check the glass cutting tools and the quality of the glass itself.

If the laminated glass is bent, the requested curved plies for the production of laminated safety glass must be bent together in pairs before lamination. A finished flat laminated glass cannot be bent, because PVB is not able to survive the high glass bending temperatures. The glass plies are cut to size from sheets of flat stock glass. It should be noted that the inside and outside plies of a curved laminate are of different sizes. After cutting, either on a machine or manually with the aid of templates, the glass edges are bevelled on a grinding machine or ground with a diamond wheel. Then the glass plies are cleaned in a flat glass washing machine. Modern glass washing machines normally operate horizontally and are equipped with rotary brushes to produce an immaculately clean glass surface solely with water. Since the quality of the washing water

and the cleanliness of the glass surface affect the adhesion of the PVB film to the glass, only fully demineralised water of $\leq 20 \mu\text{S}$ (if possible $\leq 5 \mu\text{S}$) in the final zone of the washing machine should be used. The effect of the conductivity of the washing water on the adhesion of Trosifol® film to glass is shown by the adjacent graph. In this example, a conductivity of approx. $150 \mu\text{S}$ roughly halves PVB film adhesion to glass.

Water from natural sources usually contains certain quantities of dissolved salts – mainly hardness-imparting alkaline earth ions such as Ca^{++} and Mg^{++} along with, for example, Na^+ and K^+ in lower concentrations. The former seriously diminish glass adhesion even in low concentrations, whereas the alkaline ions (in this case chloride salts) have a barely measurable effect on adhesion.



➡ Unloading of glass from rack before washing

In practice, it is therefore imperative to remove the ions through complete demineralisation or reverse osmosis. When mixing fully demineralised water with natural water, it is hugely important that the water hardness, or the specific electrical conductivity, is closely checked before and during the wash process.

Especially when detergents are used in the first washing step to clean dirty glass, it is essential to use fully demineralised water for the final rinse before the glass is then dried in a powerful stream of filtered hot air. The air jet should be angled so that any remaining droplets on the trailing edge of the pane concentrate in a single corner to aid removal.

To produce flat laminated safety glass, the washed, cleaned and dried glass plies are generally taken straight from the washing process. However, before the film is applied, the glass must have cooled to 25–30 °C because otherwise the PVB film will adhere strongly to the hot glass surface.

The effect of washing water conductivity on glass adhesion

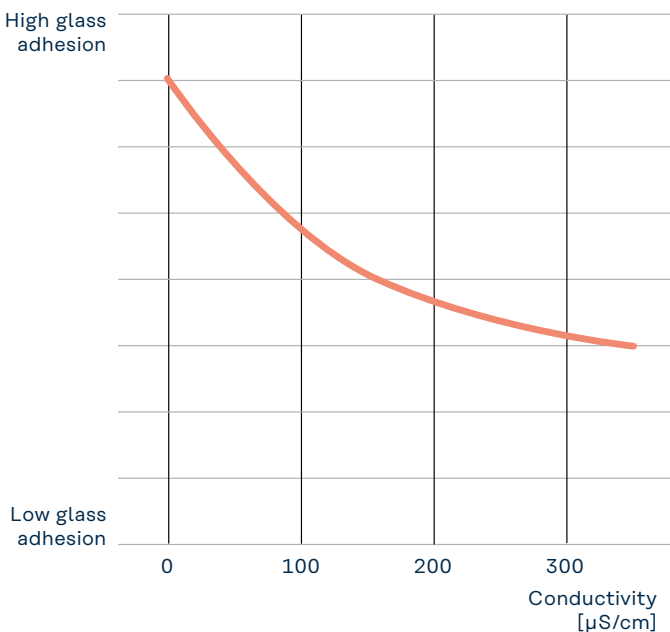

CONTAMINATION OF THE GLASS SURFACE BY

- Washing / rinsing residues ("scale residues")
- Release agents (e.g. bicarbonate, diatomaceous earth or others)
- Corrosion residues
- Cutting oils/grease
- Detergent residues from cleaning agents
- Glass chips

The effect of alkaline earth ions on glass adhesion

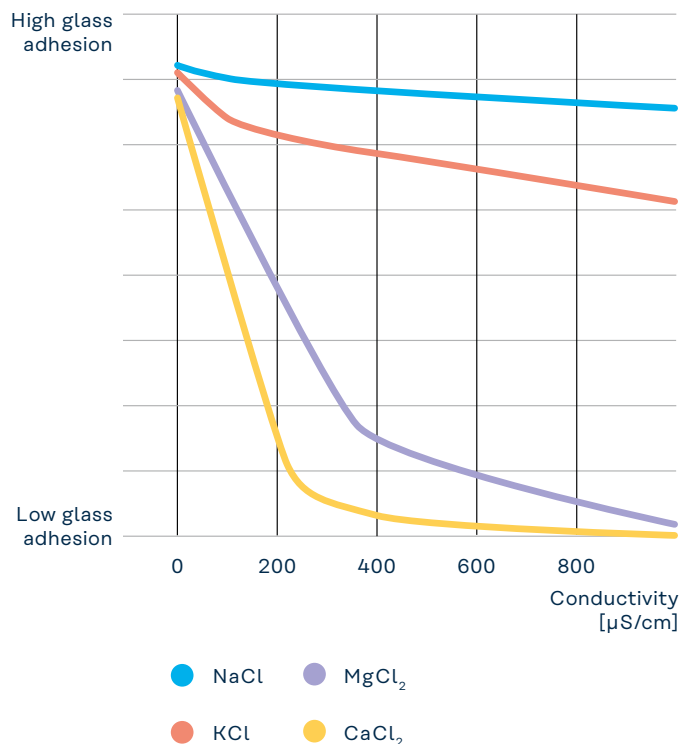

Glass washing machines typically have different sections to separate washing and rinsing and are in most cases equipped with brushes, which are rotating opposite to the glass transport direction.

In the first section tap water with a temperature of 30 – 40 °C (86 – 104 °F) is used. In a second section tap and demineralized water are mixed. In the final section only warm demineralized water is used, and after glass cleaning this water is recycled in the former section. This cascade solution is a cost saving procedure and most in-use in practice.

In the last section the glass is dried with air nozzles to remove water droplets. The line speed and the temperature have a big impact how much and how fast the residual water is blown off and how much evaporates. This can have a large influence on the later glass adhesion uniformity.

Together with the removed water also the residual salt content is removed. Higher glass and water temperature can promote the evaporation of salt thus reducing the adhesion. It is necessary to inspect the glass surface after washing and drying to avoid this problem by regular adjustment of the washing parameter.

Influence of washing quality on PVB/glass adhesion

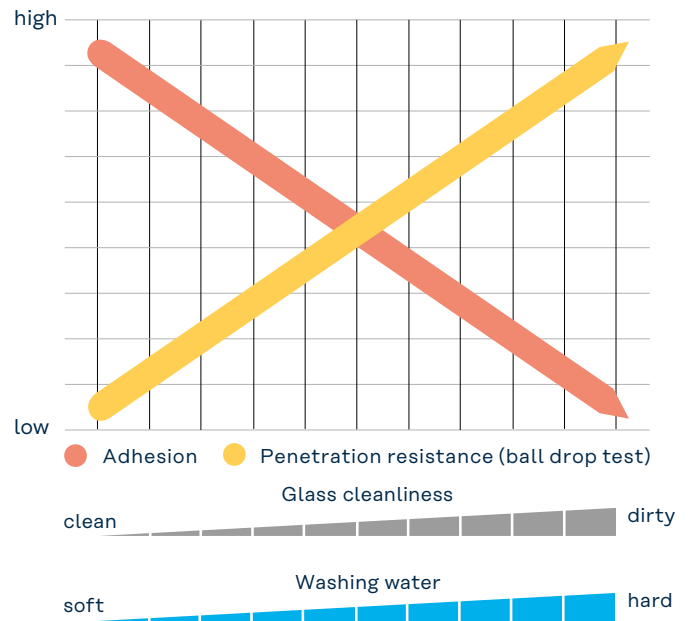

➔ Glass washing machine

4.3. PVB roll storage and handling

4.3.1. MOISTURE CONTROL PVB

As explained in chapter 2, unpacked PVB film always has to be stored under strict moisture and temperature control before use. The hygroscopic behavior of PVB causes moisture pick-up under more humid air atmosphere thus reducing the glass adhesion. On the other hand, bringing and handling open rolls into more dry climate condition causes drying of PVB beginning in the outer layers and increasing the glass adhesion. Depending on humidity and temperature the water diffuses in or out of the exposed film until a chemical equilibrium is reached. The following two graphs show the dependency of film moisture as a function of the relative air humidity.

The second graph shows the more expanded equilibrium curve in the lower range of air humidity, which is relevant for the lay-up room storage condition.

Equilibrium moisture content vs. air humidity for Trosifol® PVB (typical lay-up room conditions)

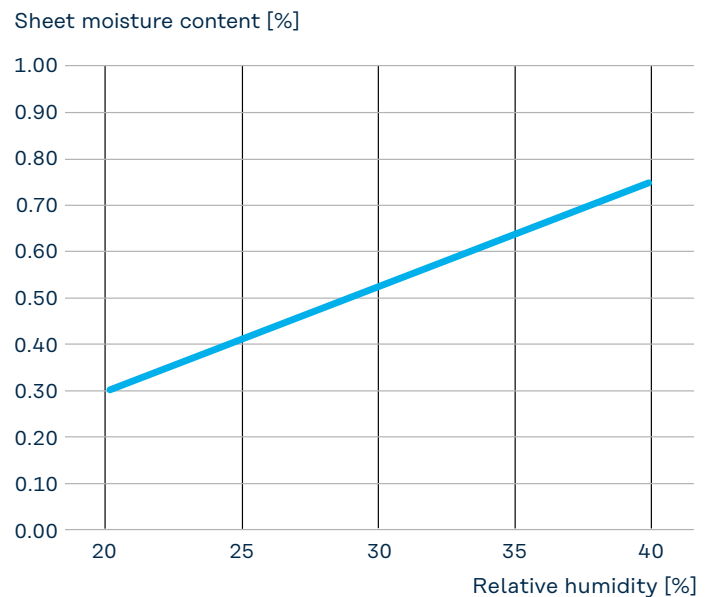

Equilibrium moisture content vs. air humidity for Trosifol® PVB

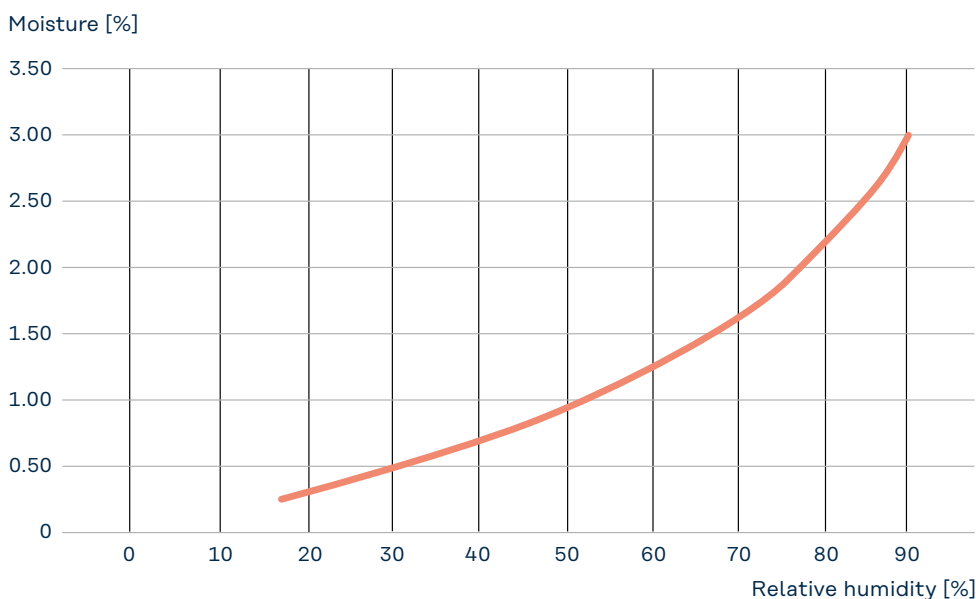

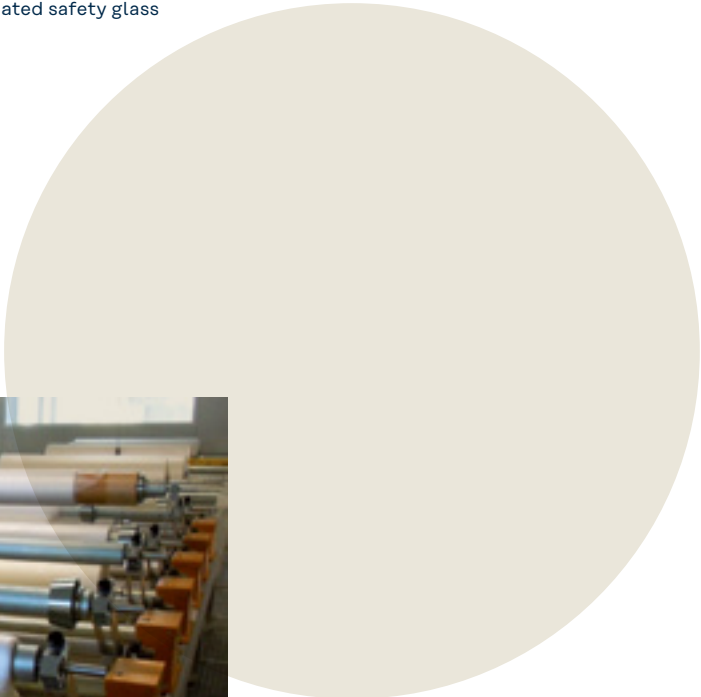
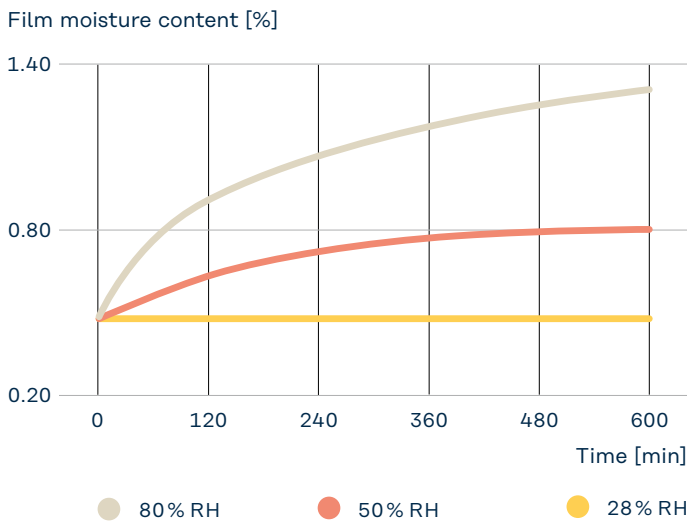

Photo: © Glaston

➔ Storage room for PVB interlayer

The moisture equilibrium adjustment by diffusion is a time and temperature dependent process. During film processing both surfaces are exposed to the surround air. The next graph shows the moisture diffusion rate of a 0.76 mm (0.030") thick PVB film starting with the initial moisture content of 0.5 wt.% at room temperature and a relative humidity in the lay-up room of 28%.

Moisture diffusion rate of Trosifol® PVB at room temperature



Most of the modern laminator lines are equipped with a storage room for PVB rolls upon the lay-up section. These are air-conditioned depending on the use of refrigerated or PE-interleaved film rolls. After unpacking of the formerly sealed rolls in a dedicated section they are lifted by a crane in the upper storage position. It makes sense to mark each of the positions with the right film label. This makes sure that always the right interlayer is used when the position number is chosen. Storage rooms may have a central chute where the chosen PVB is guided and hanging before use. For interleaved PVB the separating PE film is unwind on a separate core before feeding into the chute.

RECOMMENDATIONS FOR TROSIFOL® ROLL STORAGE

- Refrigerated rolls
 - originally sealed: ≤ 8 °C (46 °F) and humidity uncontrolled
 - opened: ≤ 8 °C (46 °F) and 25 – 30 % rel. humidity
- Rolls with PE interleaf
 - originally sealed: ≤ 30 °C (86 °F) for long-term storage and humidity uncontrolled
 - opened: ≤ 18 °C (64 °F) and 25 – 30 % rel. humidity
- Shelf life for both types refrigerated and PE interleaved: max. 4 years

4.3.2. ASSEMBLY ROOM

In the air-conditioned assembly room the marriage of glass with PVB takes place.

When combining the various layers of flat and/or curved glass plies for architectural glazing with one or more layers of Trosifol® PVB film, the film is almost exclusively delivered straight from the roll of film (the exception being small formats). For flat, large-size glass measuring up to 3.21 x 6.00 m (10.53 x 19.69 ft, so called Jumbo size), laminate assembly and film edge trimming are carried out in most cases fully automatically.

To assure the high quality of the laminate, a lot of conditions have to be fulfilled within the assembly room.



LAY-UP ROOM RECOMMENDATIONS

- Correct humidity (22-30 % RH) plus cleanliness
- Air temperature approx. 16 to 20 °C (61-68 °F)
- Lint free clothes, gloves and hair nets
- Room over pressurized to force dirt to stay outside
- Double door entrance and limited access
- Antistatic doormats
- Assembly room well illuminated – also below the glasses
- Routine cleaning of floor, conveyor rolls and overhead equipment
- Do not use solvents for cleaning
- Limited access by visitors
- No foreign materials (wood, cardboard) stored in the room
- Dedicated collecting drums for clean film trimmings



The washed glass coming through the lock into the lay-up section should have a surface temperature of 25 - 30°C (77 - 86°F). If the glass is too warm, the PVB film will be sticky on the surface causing too early edge sealing in the following de-airing step. On the other hand, pre-adhesion will be too high thus being difficult for the film positioning. Other possible consequences can be the PVB film shrinkage and snap-back on the glass surface. If the glass is too cold, slipping of the upper glass over the film can occur. The same effect will happen with too cold interlayer. On the other hand, if PVB is too warm it might stick on the glass and will be more difficult in correct positioning.

During lay-up of PVB it is very important to make sure that it lays flat on the glass and there are no folds or wrinkles. In modern PVB assembly room more and more automatic lay-up and positioning systems are used. In this case there is no operator present, meaning that exact lay-flat of PVB is very important especially for Jumbo glass format (3.21 x 6.00 m / 10.53 x 19.69 ft).

For curved glass laminates which are processed later in a vacuum de-airing equipment, the same lay-up recommendations are valid. Exception is the washed curved glass feeding, which is done separate from the flat glass procedure. And positioning and pairing is mostly carried out manually by the operator.



➤ Positioning of PVB film

Film lay-up positioning

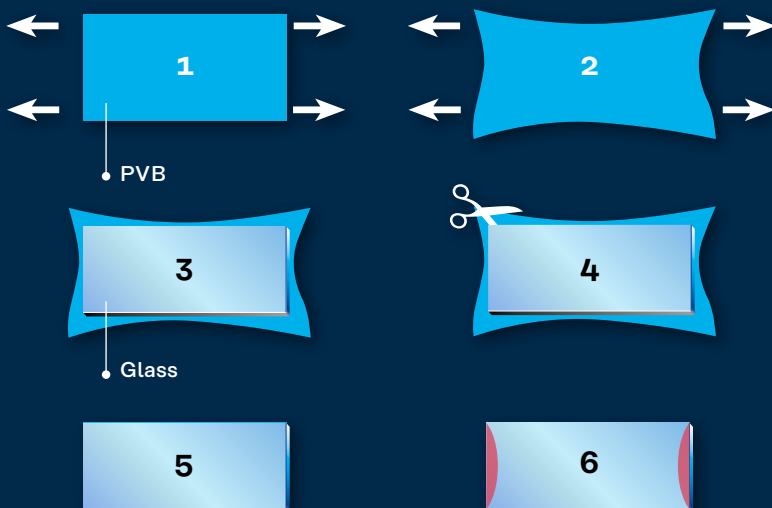

Do not pull Trosifol® too much when unrolling!

Do not pull out Trosifol® while cutting!

→ Film will snap back!



• PVB lay-flat behavior with Jumbo size glass laminates

After the assembly of glass and PVB the excess PVB sheet should be about 1 cm (0.39") on all sides. The manual cut is done with a sharp razor blade knife with a little angle and residual overlap of 1-2 mm (0.04 - 0.08") as shown on the picture below. In case of automatic trimming, the trimming system should be installed in the assembly area in order to assure that the film temperature does not exceed 20 °C (68 °F) during trimming. This practice avoids too soft inter-layer and secures a trimming process without laceration. The clean film trims are collected by type (clear, tinted etc.) in dedicated drums with PE-inlay for later re-sending and recycling.

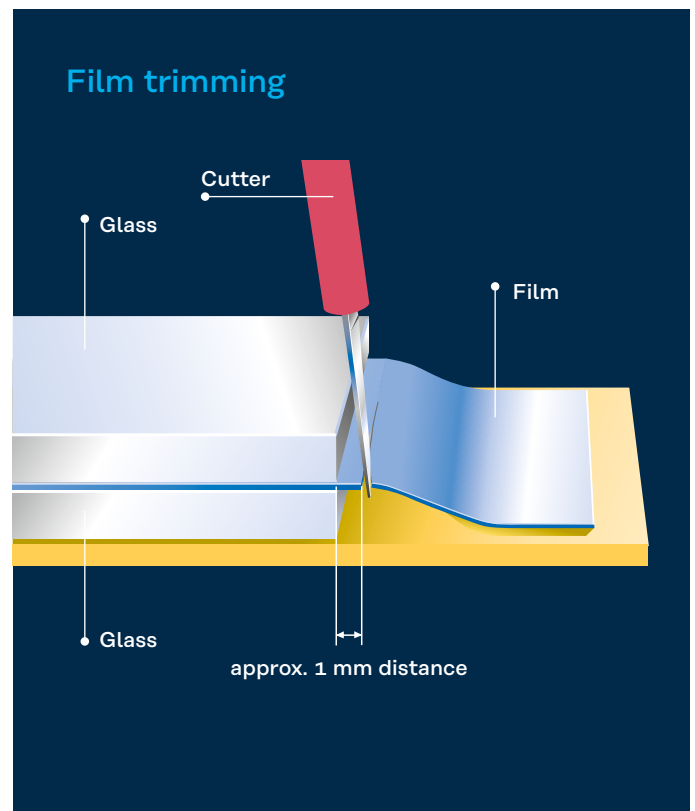

4.4. De-airing process

4.4.1. INTRODUCTION

When pairing two or more glass plies together with one or more layers of PVB film, the sandwich still contains a lot of trapped air at both interfaces. Reasons are the one hand the rough surfaces on both film sides and on the other hand a possible non flatness of the glass in case of curvature (bending deviations) or of tempering thus creating a slight waviness onto both glass sides. Annealed glass without any treatment is absolutely flat, after removal of any kind of impurities by cleaning as well as without any damage like scratches etc. If this assembly would only be pressed cold or warm in an autoclave or a static press, the final laminate would always contain a larger quantity of trapped air.

TARGET OF THIS PROCESS STEP IS

- Remove the maximum amount of air out of PVB / glass sandwich
- Tacking the glass to the interlayer to avoid separation prior to any pressing step
- Continuous sealing of the edges to avoid air penetration during autoclaving

THERE ARE 3 PROCESSES TO ARRANGE THE DE-AIRING OF AN ASSEMBLY:

- Nip roll or calender: indirect heating (convection/radiation) and area high pressure
- Vacuum bag/ring: indirect heating (convection/radiation) and air removing by low pressure
- Vacuum laminator: direct heating (conduction) and air removing by low pressure

In the following chapters each of the above laminating processes is described in more detail.

Most critical is the right balance between the air removal and the edge sealing step. The first part has to happen at lower temperatures and can only work as long as the surround edges are not sealed. This also ensures that excess air from outside does not diffuse back into the interface. Although trapped air will not be visible initially after de-airing, delamination can develop later over the laminate life time. Once the edges are fully sealed, any air removal is blocked and will cause bubbles and later delamination and bad thermal stability of the final laminate. It is important to visually inspect the pre-laminate continuously after de-airing, because this can have a big impact on the quality of the final laminate after the pressing (autoclave) step.



• Bubble formation after bad de-airing step

THE NECESSARY ENERGY AS HEAT IS TRANSFERRED INTO THE GLASS SANDWICH BY THE FOLLOWING TECHNOLOGIES:

- Radiation: form of heat transfer in which hot material energy to its surroundings. Mostly IR-radiators are used to emit radiation to heat up the glass
- Convection: implies the transfer of heat from one place to the other by fluid, in this case, air
- Conduction: happens when two materials touch each other. A hot material conducts energy from the hot material to the colder one.

4.4.2. NIP ROLL OR CALENDER PROCESS

By far the most common prelaminating process for flat laminated glass for architectural purposes is the nip-roll process. This is because it permits high processing speeds particularly for large-format laminated safety glass. Depending on the given process, nip-roll de-airing ovens with one or two heating zones and one or two pairs of rolls are used. The heating ovens can be heated with infrared radiators, hot circulating air or with electricity (hot black tubes). The rolls, in pairs, each consist of a robust, rubber-surfaced cylinder.

It has proven useful to carry out nip-roll prelamination in two steps. The loosely assembled sandwich of flat glass plies and film is heated to approx. 35 °C / 95 °F (measured on the glass surface) in a short heating tunnel with medium-wave infrared radiators. The heated sandwich is then passed through a pair of rubber rolls where most of the trapped air is expelled. After this, the assembly is fed through a second, longer infrared heating tunnel where it is heated to approx. 55 – 70 °C / 131 – 158 °F (measured on the glass surface). Any remaining air is then almost entirely expelled by a second pair of rolls and the edges are sealed. The quality of prelamination is indicated by the appearance of the pressed sandwich. The glass should have a slightly stripy, grey structure distributed uniformly over the entire surface. Only a narrow zone around the periphery of the glass (edge seal) should be transparent.

The nip of the first pair of rolls should be approx. 1 mm narrower than the overall glass and film thickness, and the nip of the second pair of rolls should be approx. 2 mm narrower. This nip may have to be reduced still further for very thick glass/PVB sandwiches when several thick film layers are used. The pneumatic cylinders of the press rolls for flat glass-film sandwiches should be operated at 5 - 7 bar / 72 - 101 psi. Since the heat transmitted from the glass surface to the Trosifol® PVB film is primarily responsible for heating the sandwich, especially in the case of multiple laminates, uniform heating of the sandwich takes a certain amount of time. Consequently, the throughput rate and the supplied heating energy must be adapted accordingly to achieve efficient prelamination. All the temperatures quoted are only guide values and depend greatly on the type of laminated glass and the type of heating in the prelaminating tunnel.

In addition to the above-mentioned process variables, there are other factors. These include the flow behaviour of the film (rheology), the film's surface roughness, the waviness of tempered glass and the type of glass coating/colour. The latter affect heat absorption in the oven and thus the surface temperature of the laminate. Reliable and complete de-airing continues as long as the glass edges have not completely bonded together. Once the edges are sealed, no remaining trapped air can escape, with the result that bubbles form in the end product. Consequently, de-airing must be carried out at temperatures that are lower than sealing temperature. At the same time, the temperature must be sufficiently high to ensure that the PVB film adheres firmly to the glass surface. Without this the laminate will separate prematurely and air can once again enter the gap between the plies.

IRRESPECTIVE OF THE PRELAMINATING PROCESS, THE AIM IS:

- Removal of the air between the PVB film and the glass surface
- Full-surface adhesion of the film to the glass to prevent premature separation prior to autoclaving
- Continuous sealing of the glass edges of the laminate so that no air can penetrate during autoclaving

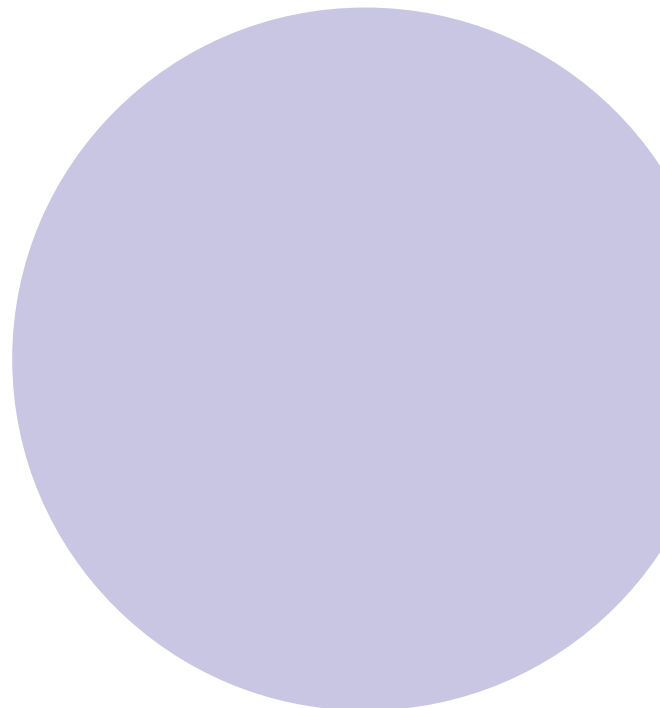

Heating systems can age. On the frequently used medium-wave radiators, it should be borne in mind that the radiated light shifts towards longer wavelengths as a result of burnt dust particles. Consequently, in the course of time, a light radiation heating system gradually turns into a forced-air heating system with correspondingly longer cycle times.

In case of thick multiple laminates the measurement of the glass surface temperature by sensors or mobile temperature measurement equipment can mislead. The temperature difference surface/core is much higher thus influencing the de-airing result significantly.



• Nip roll oven



• IR heaters in nip roll oven



• Nip roll pair

THE FOLLOWING PROCESS VARIABLES HAVE A SIGNIFICANT IMPACT ON THE BALANCE OF AIR REMOVAL AND FILM EDGE SEALING OCCURRENCE:

- Line speed
- Number and type of the IR heaters
- Power of the heaters
- Oven temperature
- Gap between rolls
- Nip roll pressure
- Glass and interlayer temperature

Temperature distribution in thin vs. thick (multiple) laminate

$\Delta T_{\text{surface/core}}$ – thin laminate



$\Delta T_{\text{surface/core}}$ – thick laminate



$\Delta T_{\text{surface/core}}$ of a thin laminate \ll $\Delta T_{\text{surface/core}}$ of a thick laminate

RECOMMENDATIONS FOR NIP ROLL PROCESS (TWO OVENS WITH 2 NIP ROLL PAIRS)

1° Stage

- Mainly de-airing
- Glass surface temperature 25-37°C (77-99°F)
- Uniform aspect/grey/without any air pockets and without edge sealing
- Roller gap: 1 mm less than total laminate thickness, multiple laminates even more
- Pressure 4-7 bar (57-100 psi)

2° Stage

- Mainly edge sealing
- Glass temperature 55-70°C (131-158°F)
- Clear aspect/closure of the edges up until 0.5 cm
- No remaining air pockets
- Roller gap: 2 mm less than total laminate thickness, multiple laminates even more
- Pressure: 4-7 bar (57-100 psi)

The perfect quality of the final laminate before the final autoclave pressing step is a result of the interaction of all line parameters and the pre-product quality. Each single adjustment can be responsible for the improper quality of the final laminate.

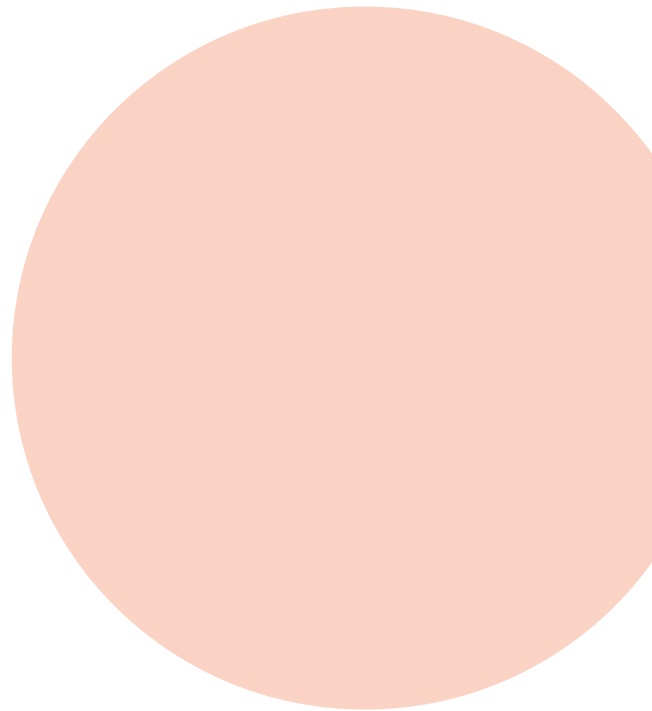

All described process parameters are valid for laminates based on two or more annealed glass plies with one or more Trosifol® PVB layers.

Because fully tempered and heat-strengthened glass has different characteristics and particularly since it is less flat than float glass, the laminating process for heat-strengthened glass with Trosifol® requires a number of fundamental changes compared to that described above.

For the production of architectural laminated safety glass consisting of two or more layers of fully tempered/heat-strengthened glass, Kuraray recommends preferably using PVB films with high glass adhesion (e.g. Trosifol® UltraClear, HR ...).

1. The following rules have proven helpful in practice for the production of good-quality laminated safety glass:

- Kuraray recommends choosing the supplier of the tempered glass carefully. They must be able to guarantee a high, unvarying quality.
- PVB can compensate for differences in flatness between two tempered glass plies by up to approx. 10 % of the total thickness of the PVB film. If the difference exceeds 10 % of the film thickness, it is very difficult to produce flawless laminated glass.
- The difference in flatness between two superimposed tempered glass plies (without interposed PVB film) can be established with a feeler gauge or straightedge; the glass orientation must be the same as in subsequent lamination with PVB.
- Differently tempered plies should never be combined in laminated glass.

Nip roll line adjustment interactions

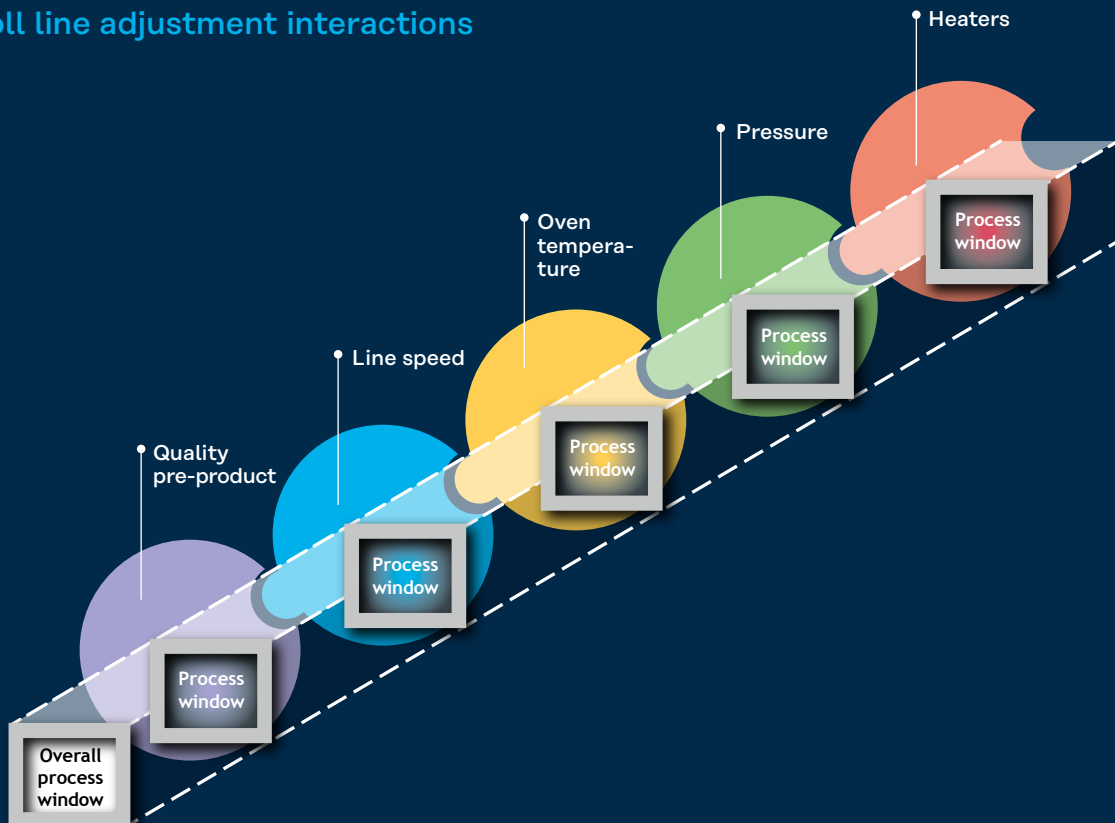

2. Glass marks on two plies of tempered glass must be face up to ensure that the glass orientation of the plies is identical. The stamp on the glass can serve as a guide, although care must be taken that the stamp position is always the same. If the stamp is missing, a subsequently applied marking can also be used to indicate the direction of throughput of the glass plies from the tempering furnace.

3. If the measured flatness is larger than stipulated in point 1, thicker layers of PVB film (1.52 mm or thicker) should be used, in case of doubt.

4. Rules for prelamination:

- The feed rate in the nip-roll system should be lower than for the same assembly with float glass and the air temperature should be lower to avoid premature edge sealing.
- Reduce the pressure of the 1st pair of rolls to avoid premature edge sealing.
- The pressure of the 2nd pair of rolls should be higher than for the same assembly with float glass to improve the edge seal of the prelaminate.
- For perforated laminated glass and particularly in the case of unusual glass geometries, the throughput rate should be manually reduced.



Photo: © Kuraray

• Laminated tempered glass nip roll result

LAMINATION OF TEMPERED GLASSES

- Quality and durability of the final laminate is significantly determined by the flatness of the tempered glasses
- Roller waves
- Recommended flatness of tempered glass $\leq 0.15 \text{ mm} / 300 \text{ mm}$ (0.59"/11.81")
- Local and overall bow
- Unevenness of the edges
- When layed up with another lite, the total gap should be less than 0.15 mm

4.4.3. VACUUM PRELAMINATING PROCESS

The vacuum prelaminating process is primarily used for the effective de-airing of curved glass and multiple glass/film laminates. This is because even special nip rolls cannot expel all the air from such glass constructions, and frequent glass breakage would be the result. The vacuum process takes place either in a rubber bag (Asahi process), in suitably temperature-resistant bags of bonded films, or with the aid of rubber profiles. The glass assemblies evacuated in this manner are heated in a forced-air oven. The bags can hold one or more glass prelaminate, depending on their size. Since the rubber bag is easier to fill, this process is also suitable for a continuous oven handling large series at air temperatures of approx. 100-120°C (212-248°F).

RECOMMENDATIONS FOR VACUUM BAG/RING PROCESS

- Initial temperature 20-30°C / 68-86°F
- Cold vacuum: minimum 20 minutes (depending on size and glass build-up)
- Vacuum level: 0.1-0.3 bar / 14-43 psi
- Hot vacuum process up to 130°C / 266°F with a holding time of at least 30 minutes (depending on size and glass build-up)

In all vacuum prelaminating processes, it is necessary to ensure that most of the air has been evacuated from the glass plies before heating commences (approx. 10 minutes – a little longer is better). This is the only way to avoid incomplete de-airing before the edge is sealed. The vacuum must be maintained throughout the heating process (approx. 20 minutes) and should be at least 0.1 to 0.2 bar (14-29 psi) (-0.8 to -0.9 bar/approx. 60 to 200 hPa). The vacuum before the rubber bag or ring is important here, as it can differ from the vacuum immediately at the pump. The prelaminate produced in the vacuum process is usually clearer than the one processed in the nip roll process due to higher temperatures and much longer de-airing time.

In some cases, a continuous vacuum process is used, mostly for larger series of same or similar sized (curved) laminates. But this process is more dedicated to car windscreen glasses, but can also be adapted for not so thick flat laminates. Important is the use of rubber rings connected to vacuum adapters, a balanced cold vacuum zone as well as a homogeneous hot vacuum zone.

Continuous vacuum bag process

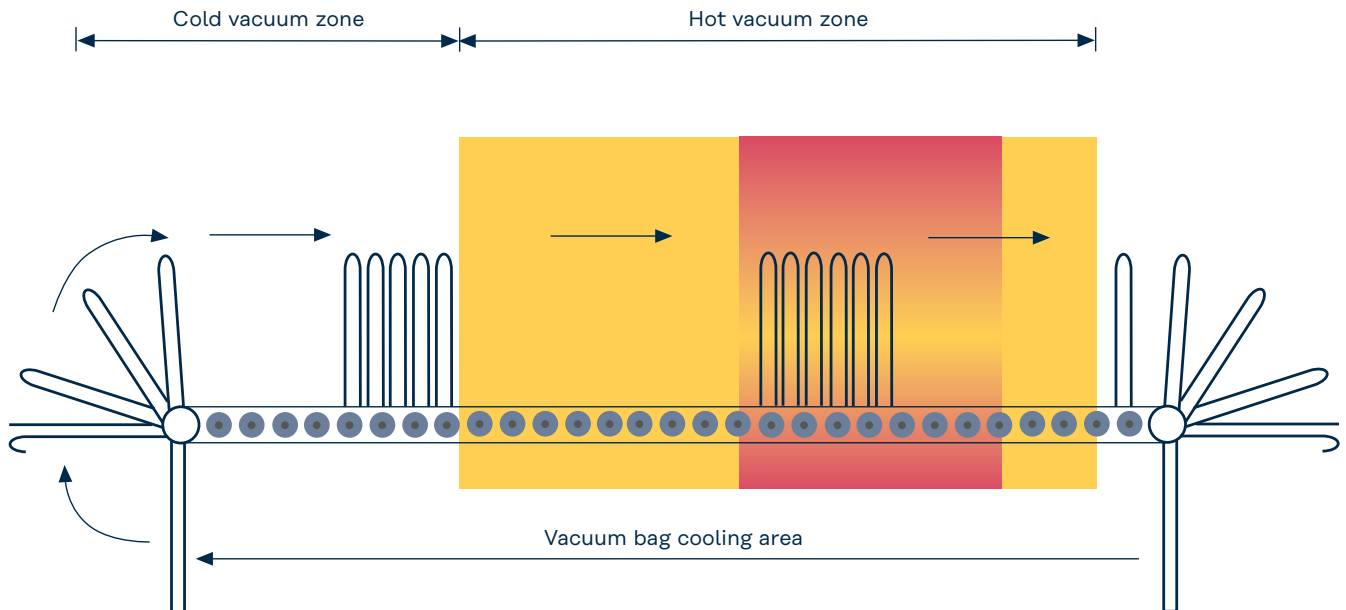

4.4.4. VACUUM PROCESSING IN A (SINGLE OR MULTI LEVEL) LAMINATOR

VACUUM LAMINATION (SINGLE-STAGE)

As a non-curing thermoplastic, Trosifol® is able to be processed also in a vacuum laminator in a one-step process. The principle is direct heating by conduction onto a heatable metal plate. Into this plate a lot of pins are integrated which are able to move up and down the laminate during the vacuum process.

The vacuum chamber is loaded from the top with the laminates and tightly closed. The laminates are laminated at temperatures of roughly 140 to 160 °C and a vacuum of 1 mbar or less. A membrane divides the chamber into an upper and lower segment. This applies pressure to the laminates via the pressure in the upper chamber at a maximum of 1 bar (= external atmospheric pressure).

The pressure in the upper and lower chambers can be separately adjusted. The principle of a lamination process is shown in the following diagram. The heating plates are equipped here with pins that, by lifting the laminate, slow the laminate's rate of heat uptake.

In contrast to the above described conventional vacuum processes a much higher vacuum of 1 mbar (0.015 psi) or less is usual. Due to the fast de-airing speed, high vacuum and direct heating the de-airing batch process is much faster. The process cycle time is possible from 15 minutes per cycle upwards depending on the laminate thickness and type and laminator configuration (single- or multi-level laminator).

Principle of the single-level laminator

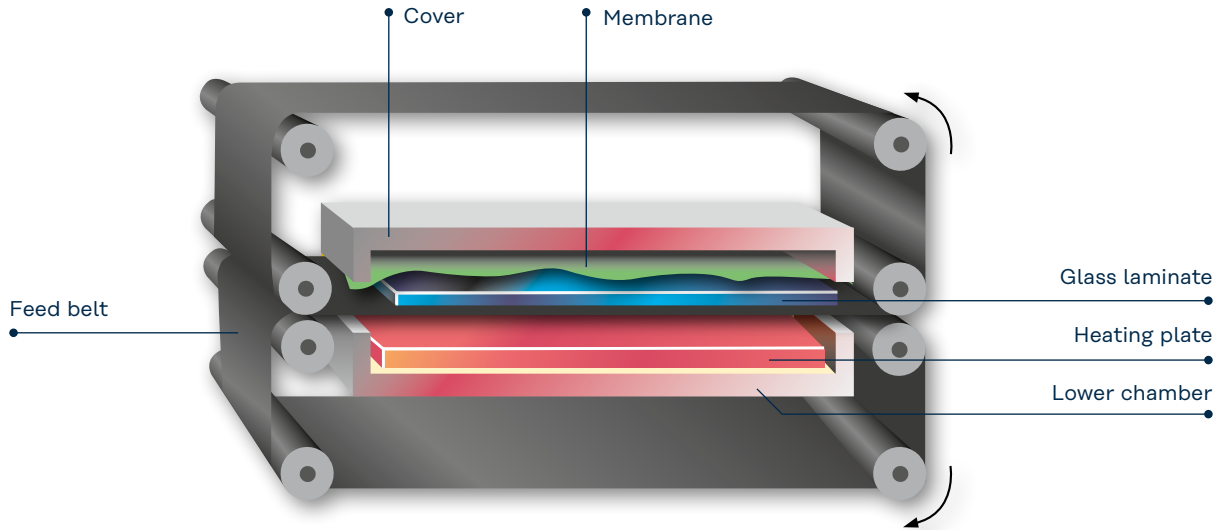

Basic process for PVB in the single-level laminator

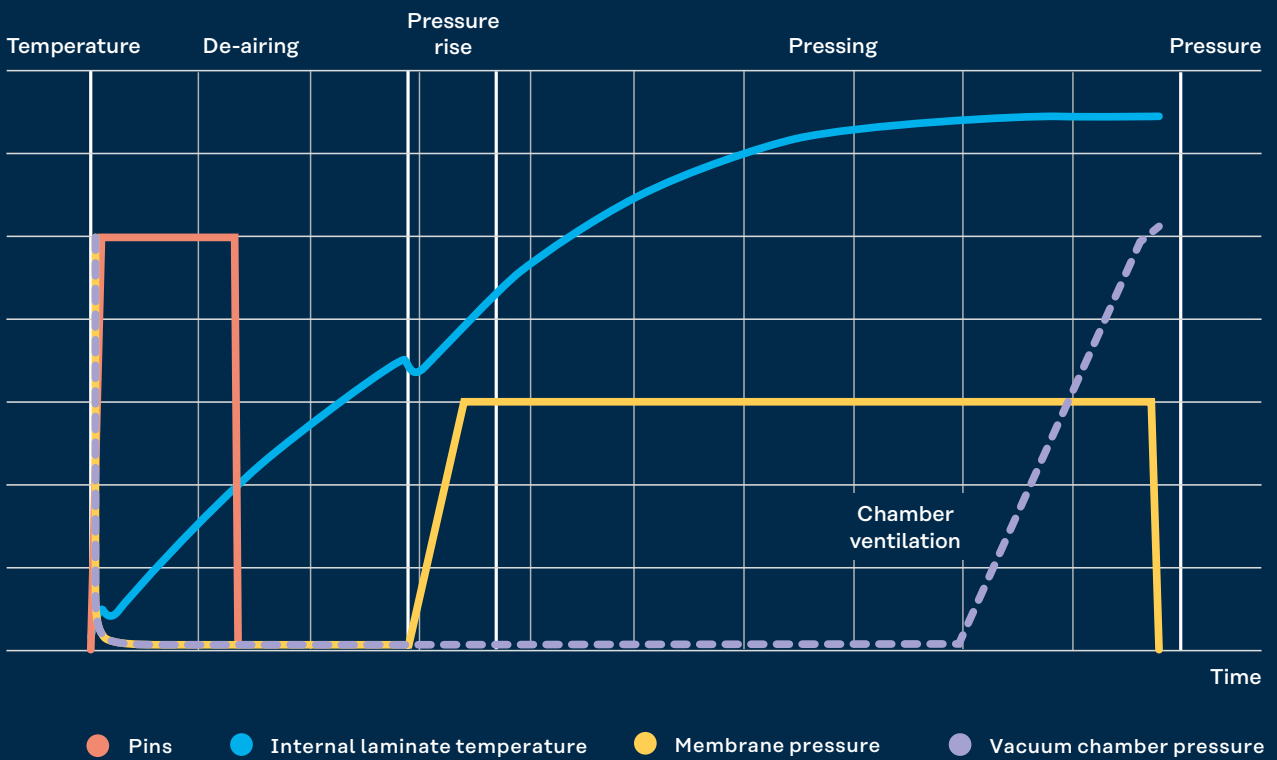

STACK LAMINATION (MULTI-LEVEL)

Compared to the single-level laminator, the stack vacuum laminator is more efficient, achieves higher module throughput with shorter cycle times and hence shorter process times. It can be used e.g. for solar modules with crystalline solar cell strings as well as with other breakage sensitive inlays incorporated between PVB and glass in a single or multilayer laminate. The stack laminator is available in 2-stage and, with cooling step, also in 3-step configuration.

ADVANTAGES OF VACUUM LAMINATOR

- Very low edge flow during the lamination process (high edge strength)
- No contamination of the glass surface, e.g. by contaminated membrane
- Very good de-airing thanks to textured film surface
- Longer service life of laminator membrane and other components/longer oil change intervals (no release of corrosive gases)
- Very fast cycle time and throughput possible
- No necessity of 2nd autoclave step (if tests of LSG quality are fulfilled)
- Usable for pressure sensitive inlays (like solar cells etc.) in glass laminates

Multi-Level vacuum laminator

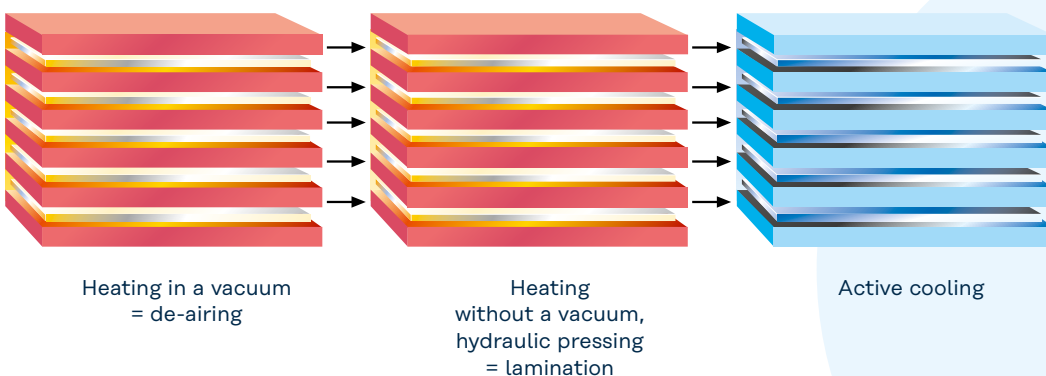

4.5. Autoclave process



Photos: © Claston

The autoclaving process is the last step in the production of laminated glass. The autoclave is heated either electrically or alternatively with steam or oil. To achieve a uniform temperature distribution in the autoclave, fans are usually installed to recirculate the air. The quality of this process depends on the right temperature, pressure and time and determines:

- how much residual air is effectively released
- how the contact between the glass and film is made possible by the film's flow behaviour

Just before starting the autoclave cycle the movable rack has to be loaded. To ensure a proper and efficient heating it is necessary to equip the stacked glass pieces with separating tools. These can be special blocks, sheets or rods as shown in the below pictures.

TARGET OF THE AUTOCLAVE STEP IS

- to dissolve the remaining air left from the de-airing step under heat and pressure
- allows for viscous flow of the interlayer resulting in intimate contact between the interlayer and the glass
- to achieve the desired adhesion level between glass and PVB by intense contact between glass and PVB

Separating blocks

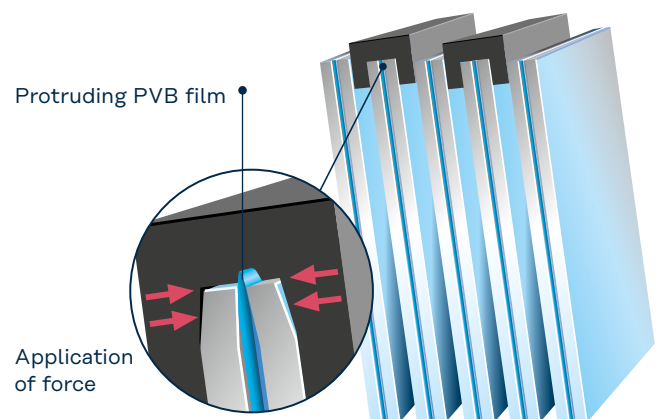

REASONS FOR THE USE OF THESE SEPARATING TOOLS ARE

- The air must be able to circulate around the laminates
- Hot spots can be responsible for optical distortion
- Direct contact between glasses can cause points of pressure causing optical distortion in the laminate
- No direct contact between glass and metal possible → no risk of cracks

The laminates must be stacked in the autoclaves so that effective heat exchange is possible between the laminates. Missing spacers result in glass contact and hence pressure points that reveal themselves as visible flaws during final inspection. This is why separating blocks or rods are absolutely essential.

Tailor-made separating blocks are most frequently used for the stacking of the pre-laminates. The materials used for this are plastics such as nylon, Teflon and EPDM.

Separating sheets are also widely used. These sheets are coated metal plates on a rigid connecting rod that hold the laminate in a vertical position. Alternatively, (silicone-sheathed) separating rods, as illustrated, can be used, although these can restrict the air flow in the autoclave and cause optical distortion in the glass plies due to uneven pressure distribution. In all cases, direct contact between the glass and metal must be avoided because of the temperature differences that can cause breakage. Normally, the spacing between the laminates should be equal to laminate thickness. Laminates clamped too tightly in the autoclave frame can result in thinner areas in the film, thus causing visible flaws.

IMPORTANT:

The storage time between prelamination and autoclaving should be as short as possible and not more than 24 hours.

Separating sheets

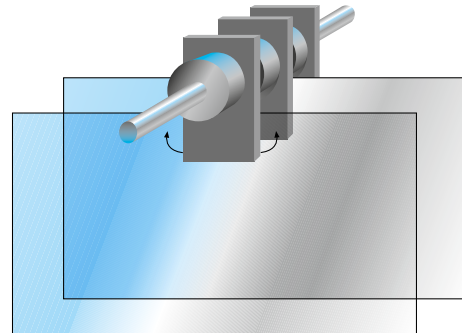

Separating rods

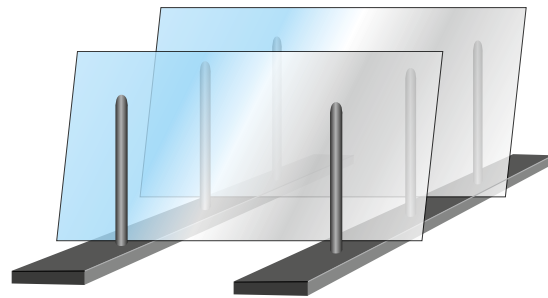

Temperature distribution in the autoclave

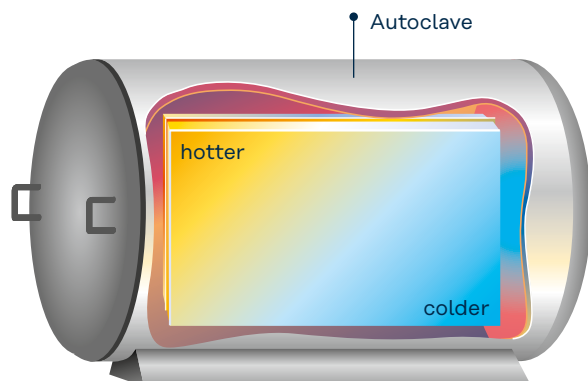

The final laminate is produced in autoclaves that uniformly apply pressure and heat to the entire glass surface. The laminates are prepared for autoclaving in the rack, as already described. The air in the autoclave can be heated electrically or with heat exchangers. The compressed air can be supplied directly from a compressed-air tank or compressors. The steel cylinder is normally insulated on the inside; however, there are also models with exterior insulation. The purpose of the pressure process is to ensure dissolution of all the remaining air in the molten PVB film. The air dissolves readily in PVB at process temperature. The air diffusion speed increases linearly with pressure and exponentially with temperature. The PVB's adhesion to glass is induced by the intensive contact, although the temperature achieved has a greater effect on final adhesion than pressure. The autoclaving process consists of three phases:

1. HEATING

Pressure and temperature are increased. This can take place in parallel or alternately.

2. HOLDING TIME

This is the time during which the laminates are exposed to maximum pressure and maximum temperature. Holding time depends on the quantity of glass in the autoclave. Holding time should be at least 20 minutes for very thin laminates to ensure that they are pressed for long enough at maximum pressure and temperature.

Bear in mind that, in spite of efficient ventilation, the temperatures are highest at the top at the door, and lowest at the bottom at the rear of the autoclave. The pressure during holding time and subsequent cooling should be approx. 12 bar / 174 psi, and the temperature during holding time 135 – 145 °C / 275 - 293 °F. The autoclave temperature should be checked roughly every six months with temperature-sensitive tapes located at different positions on the plies. This makes it easy to identify any differences between the temperature indicated and the actual internal temperature. Temperatures in excess of 160 °C / 320 °F must be avoided, as these may cause the film to flow out of the edge and gain a yellowish discolouration. Laminate quality depends, among other things, on the pressure, temperature and holding time of the autoclave process. If the autoclave is not approved for the required pressure of 12 bar, autoclaving can still proceed at a lower pressure, but for a longer holding time. It is essential to keep to the required temperature of 135 to 145 °C, because the risk of flaws increases significantly at low autoclaving temperatures. The right settings for the process parameters yield an end-product with the required properties. Thicker, large-format laminates require an autoclaving process that differs from that for thinner laminates such as windscreens.

Thicker plies have to be heated and cooled more slowly so that the laminated glass is free of stresses. The entire cycle time depends on the equipment and amount of glass and can vary between 1 and 6 hours, depending on the programming for pressure increase, pressure level and temperature curve. The process parameters can be optimised by conducting in-house tests.

Trosifol® autoclaving process – 90 minutes

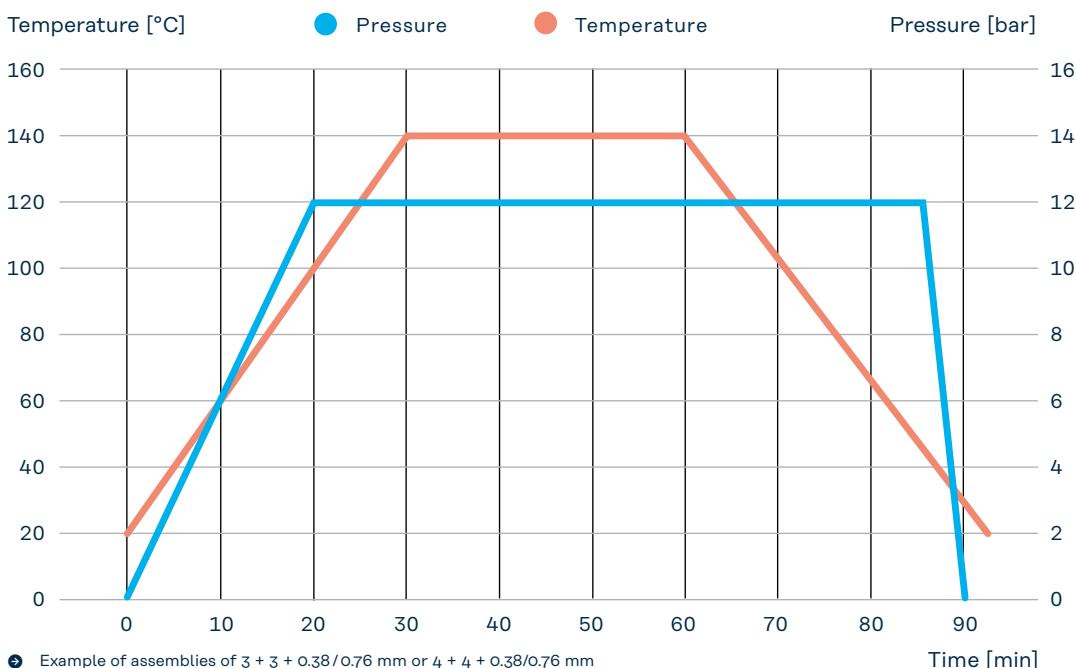

Temperature Metric/Imperial

°C	°F
160	320
140	284
120	248
100	212
80	176
60	140
40	104
20	68
0	32

Trosifol® autoclaving process – 135 minutes

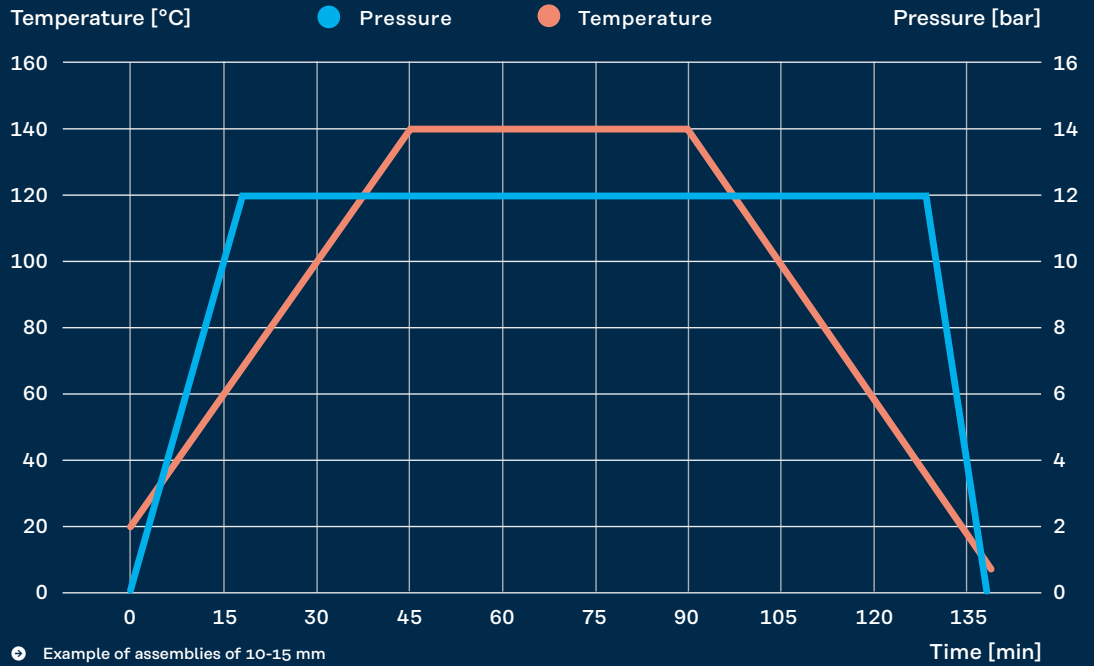

Pressure Metric/Imperial

bar	psi
16	232
14	203
12	174
10	145
8	116
6	87
4	58
2	29
0	0

Trosifol® autoclaving process – 165 minutes

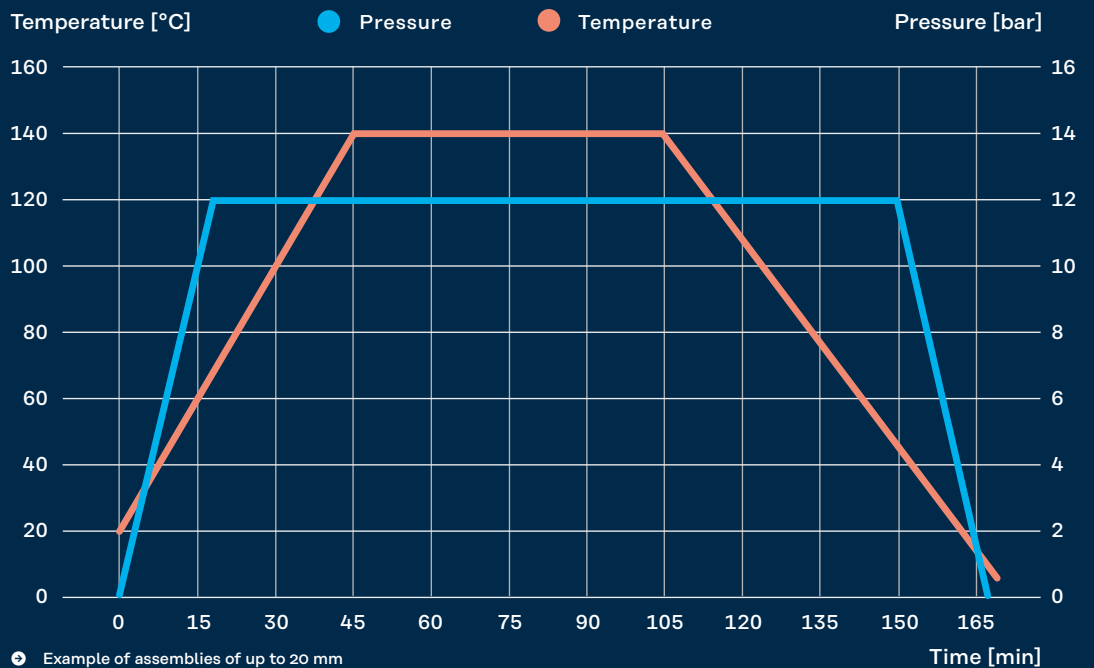

Trosifol® autoclaving process – 270 minutes

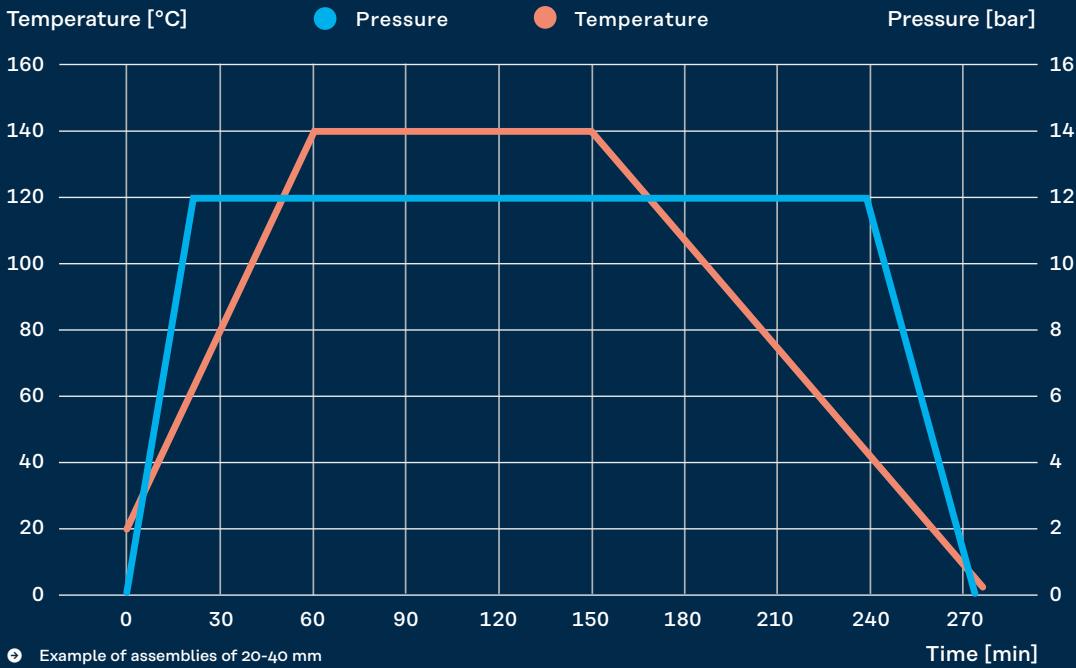

Temperature Metric/Imperial

°C	°F
160	320
140	284
120	248
100	212
80	176
60	140
40	104
20	68
0	32

Trosifol® autoclaving process – 360 minutes

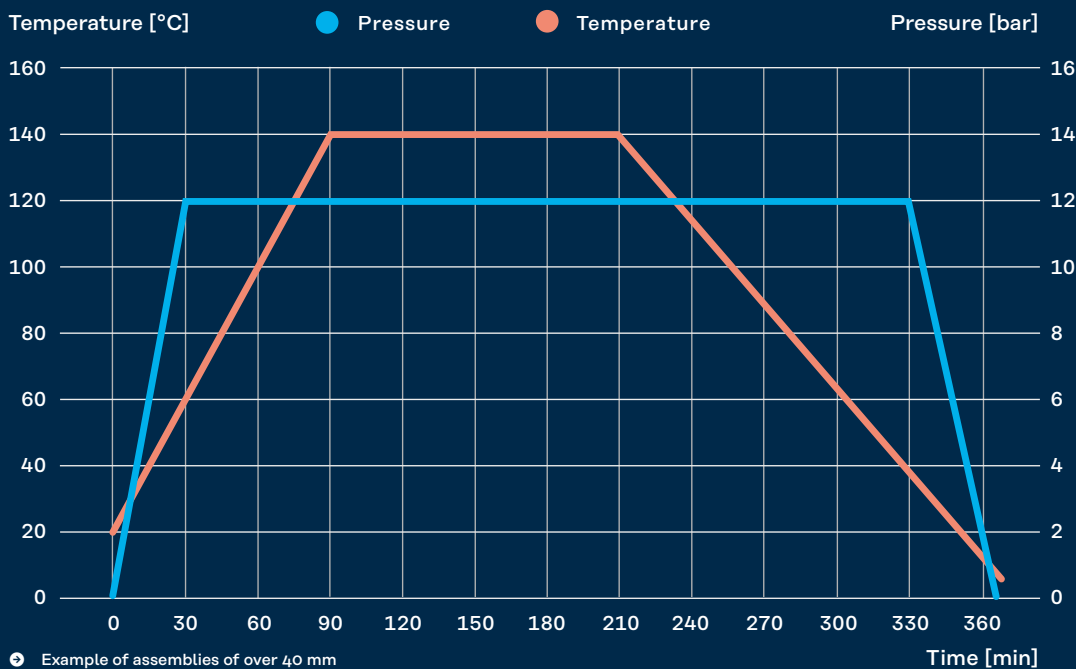

Pressure Metric/Imperial

bar	psi
16	232
14	203
12	174
10	145
8	116
6	87
4	58
2	29
0	0

FOR THE AUTOCLAVING OF TEMPERED GLASS OR HEAT-STRENGTHENED GLASS BASED LAMINATES SOME SPECIAL RULES ARE HELPFUL:

- Set slightly higher temperatures than for float glass
- Autoclave for longer cooling time compared to annealed glass laminates to avoid later delamination
- Pressure should be applied to the area around holes in perforated laminated glass if necessary before autoclaving

In the case of drilled holes, the film should be

- either given a single incision
- or incised with a cross-cut.

The production of flawless laminated safety glass consisting of two (or more) heat-strengthened glass plies is easier if these rules are observed.



• Clips/Clamps for laminate edges

3. COOLING

The glass in the autoclave is cooled to a surface temperature of approx. 40 °C / 104 °F, with the full pressure being maintained throughout the cooling phase. It is important that the autoclave is only depressurised after the cooling process. Premature opening of the autoclave at high temperature can cause tiny air bubbles to develop along the glass edges. Glass-film sandwiches that still have bubbles after autoclaving can only be successfully autoclaved a second time if the bubbles occur in small numbers and at the edges. Trapped air in the centre of the windscreen will not be removed in a second autoclaving process.

The glass temperature inside the autoclave should be checked at different points as soon as the autoclave is opened.

A number of maintenance and precautionary measures are recommended to ensure reliable autoclave process control in the long term:

AUTOCLAVE MAINTENANCE

- Prevent the accumulation of plasticiser within the autoclave/internal insulation/glass spacers.
- Regular interior tank cleaning by heating in accordance with the manufacturer's instructions, e.g.:
 - 1.) Heat to 150 °C / 302 °F at = 5 bar / 72 psi
 - 2.) Hold for 30 minutes
 - 3.) Reduce pressure to zero within 20 minutes
 - 4.) Reduce temperature
- Prevent the accumulation of flammable liquids, e.g. from lubricants, stacking aids, etc.
- Do not leave any auxiliary substances or other flammable materials in the autoclave (wood, paper, plastic, cleaning cloths, gloves, etc.).
- Regularly service the compressor's filter system.

4.6. Final Inspection / Post-treatment of laminated glass

The finished laminated safety glass is removed from the autoclave, inspected and packed.

Laminated glass for the building industry, including multiple laminates, can then be further processed. It can be drilled, cut into smaller sizes, and the edges can be ground and polished.

Laminated glass consisting of two glass plies and a film interlayer can be divided up by cutting on both sides with a glass cutter. Normally such laminated glass is broken along the line of cut after the first and second cut, while the film is cut by heat or with a thin sharp blade. Multiple laminates consisting of three or more plies of glass must be sawn with a diamond saw blade.

Other mechanical methods are cutting with a high-pressure water jet or with the aid of special lasers. These achieve precise cuts even of multiple laminates and unconventional glass geometries. The fraying of PVB films at the cut edge is absolutely excluded.

FINAL INSPECTION LAMINATED GLASS

Checks for

- Scratches, fragments and breakage in the glass
- Projecting PVB film (edge flow)
- PVB film shrinkage
- Delamination in the interior and at the edges
- Optical distortion
- Interlayer defects (inclusion, dirty spots, cloudy spots/ not molten PVB)
- Defects around drilled holes (delaminations, cloudy spots etc.)



4.7. Laminated glass production without autoclave

PRODUCTION PROCESS

Clean the glass and, for the last washing step, use demineralised water for rinsing, and then dry.

For autoclave-free processing, it is advisable to dry the PVB film – particularly suitable for this is Trosifol® HR – freely suspended for at least 12 hours at $\leq 10\%$ relative humidity (with autoclaving: 25 – 30%) at a temperature of less than $+25^\circ\text{C} / 77^\circ\text{F}$. Insufficiently dry Trosifol® has bubbles in the finished laminate!

To prevent renewed moisture absorption, the dried films should be quickly processed in an air-conditioned ($< 25\%$ relative humidity) and low-dust room. If air-conditioning in the assembly room is not possible, the PVB film must be immediately processed (with the risk of moisture absorption by the film and bubbles in the end-product).

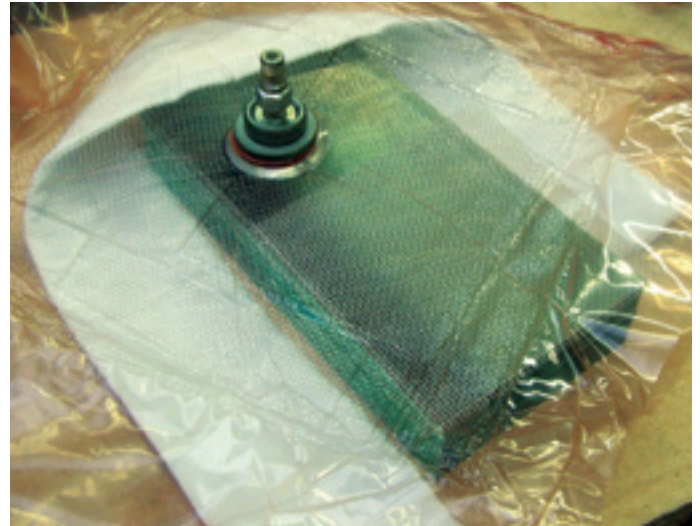

PROCESSING IN A PLASTIC VACUUM BAG

- Lay the heat-resistant ($> 135^\circ\text{C} / 275^\circ\text{F}$) vacuum film (twice the size of the laminate plus allowance) on a table and lay the first glass ply on it (possibly with a large allowance to ensure reuse of the bag).
- Lay a dry film on the glass, followed by the second glass ply.
- Enclose the glass assembly on all sides with a nonwoven fabric ('bleeder' or 'breather': reusable fabric – best of all reinforced with a metal lattice – sewn into a fabric tube). Affix the nonwoven fabric with heat-resistant adhesive tape to the laminate. Lay a strip of nonwoven fabric across the laminate so that it is in contact with the edge fabric. Incise a small cross-cut for the vacuum valve in the cross fabric, insert the valve and screw together.
- Wrap the heat-resistant vacuum film over the glass-film laminate and seal the three open sides. Two methods:
 - a) Use double-sided thick adhesive tape.
 - b) Seal with welding tongs/automatic welder.

PROCESSING IN A RUBBER VACUUM BAG

- Place the glass-film sandwich in the rubber bag and seal the bag.
- Ensure that the bag is vacuum-tight. Experience has shown that rubber bags tend to be less vacuum-tight than the other systems.

PROCESSING WITH A VACUUM RING

- Fasten the vacuum ring (rubber lip frame) to the glass-film sandwich. It is advisable to always produce vacuum rings with the same dimensions since they can be re-used.

PRODUCTION PROCESS

- Generate the required vacuum (0.1 bar / 14 psi or lower); a small vacuum pump is sufficient.
- Wait until the air trapped in the glass-film assembly has been almost completely evacuated.
- Check the vacuum: kink the feed hose by hand and wait for a few seconds. Hold the hose against your ear and unkink it; a hissing noise indicates flowing air and hence a leak in the system. Eliminate the leak.
- Generate a 'cold' vacuum; at least 20 min.
- In a force-air oven (with a uniform temperature distribution), heat to 135 °C / 275 °F at normal pressure and in a continuous vacuum.
- The holding time for thin laminates after(!) reaching 135 °C / 275 °F is approx. 30 minutes; the holding time is correspondingly longer for thicker laminates.
- Cool down in a vacuum (temperature of the glass laminate < 50 °C / 122 °F).
- Remove the laminated glass.

Example of a 140-minute autoclave-free process

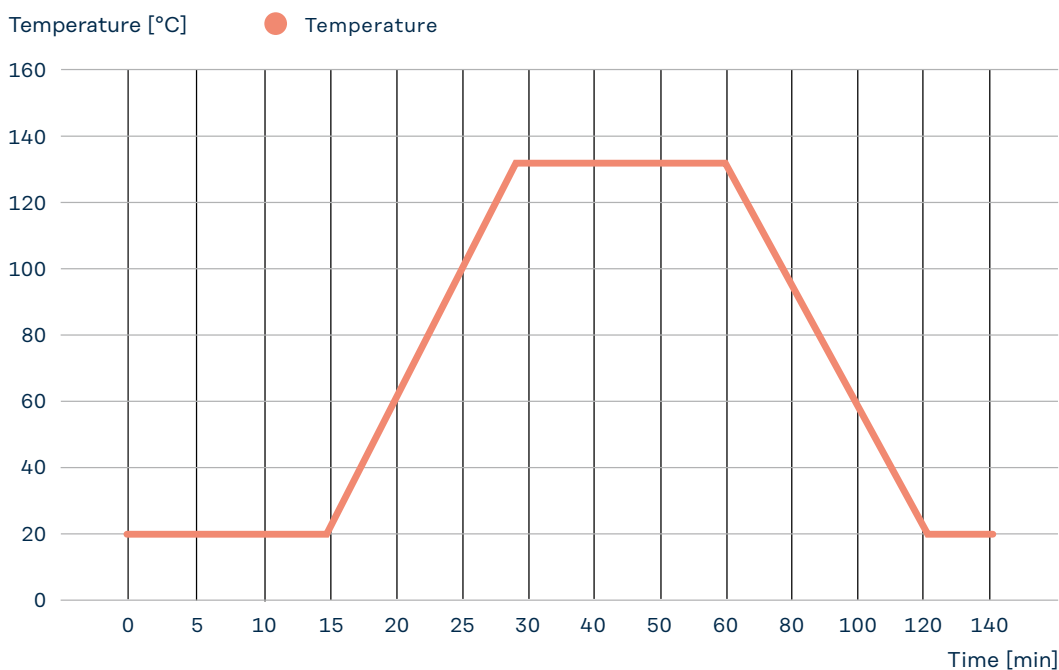

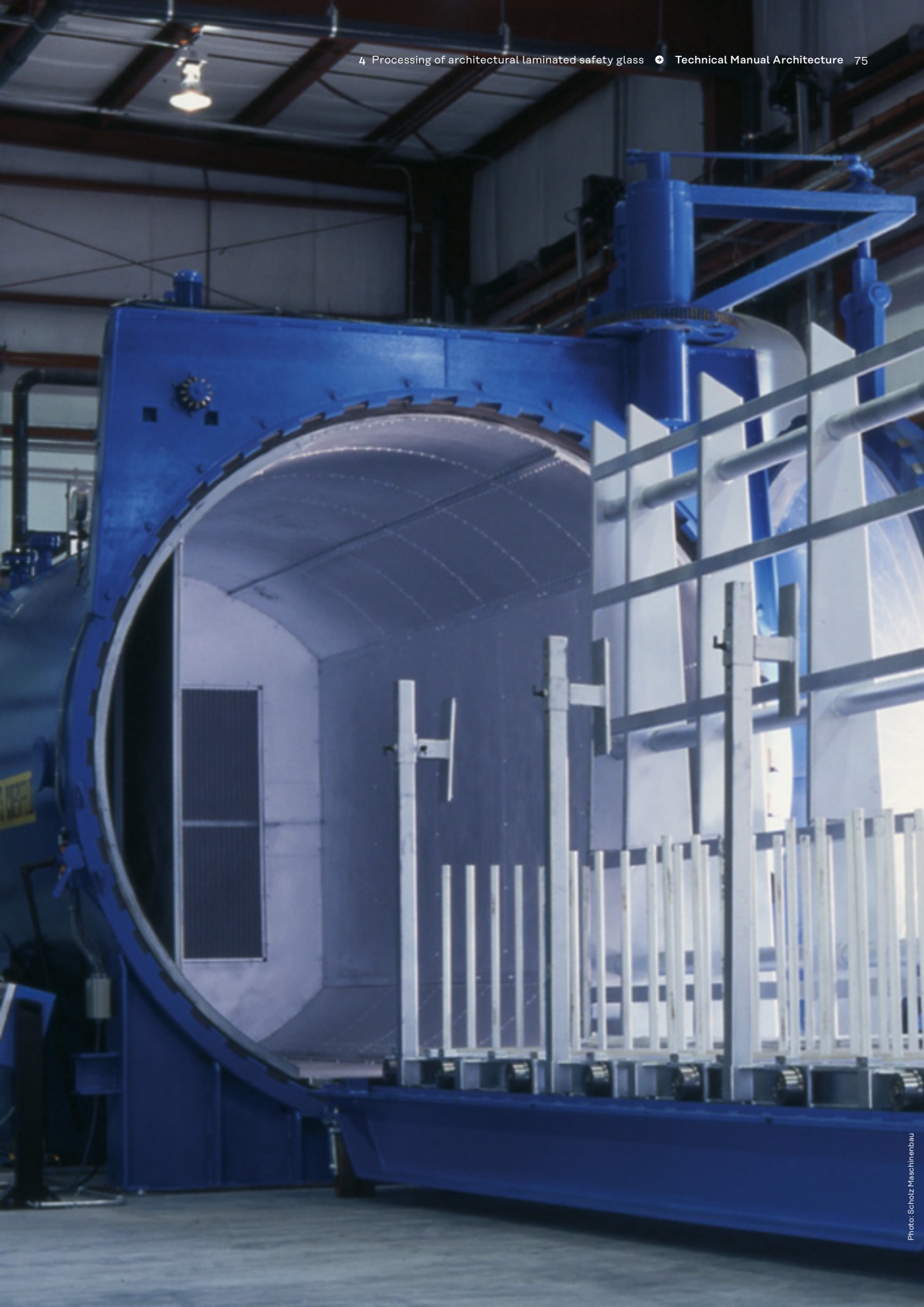

4.8. Further process instructions

In addition to the processing instructions given above, Trosifol® makes the following recommendations:

TROSIFOL® RECOMMENDATIONS

- The combined use of coloured/white translucent films with clear products is definitely not recommended (risk of haze in the laminated safety glass). The processor accepts responsibility for colour variations in the end-product.
- The combined use of white translucent and coloured films is not recommended either, for the same reasons.
- The visual effect of 0.38 mm / 15 mil white translucent film in laminated safety glass is largely the same as that of 0.76 mm / 30 mil. Consequently, given a total thickness of 0.76 mm / 30 mil, it is advisable to use 0.76 mm / 30 mil directly in order to exclude the risk of using of 0.38 mm (15 mil) clear/0.38 mm (15 mil) translucent, for the same reasons as above.
- When processing coloured Trosifol® products, account should be taken of the possible variable colouration of tinted glass. Trosifol® recommends the use of film from a single production lot as well as glass from the same batch for the production of laminated safety glass.
- Trosifol® always recommends the use of architectural products with the same glass adhesion. For instance, the combined use of Trosifol® films with different glass adhesion – for instance, Trosifol® UltraClear with Trosifol® Clear – as the interlayer in laminated glass may yield different results in tests relating to adhesion (e.g. ball drop test, etc.).
- If other materials that come into permanent contact with Trosifol® are used, it is essential to test their compatibility beforehand
- Trosifol® architectural films should never be combined with Trosifol® Sound Control Monolayer. Different acoustic properties can be expected in particular (lower R_w values than listed in the tables, for example on Chapter 6.5.
- Trosifol® architectural films must never be laminated with polycarbonate products instead of float glass. Plasticiser migration can cause stress cracking and corrosion, which result in delamination and optical distortion in the laminated safety glass.
- When integrally laminating extraneous materials such as plastics, metals, stone, wood, cotton etc. between two PVB films and plies of glass to achieve new designs or functions, their compatibility with Trosifol® must be checked beforehand. If these are water-containing or water-absorbent porous materials, they may impair the adhesion of PVB to glass. The same applies to contaminations of the surfaces of these materials with foreign substances (e.g. greases on metal, dust/abrasion between the layers), which, if unremoved, can significantly shorten the service life of the laminated safety glass.
- Some of the processing instructions are separately listed in the Trosifol® delivery documents.



Photo: © Reed Jones Christoffersen Ltd

Chapter 5

Architectural Glazing standards

5.1. Overview of global architectural laminated safety glass standards

There are a number of global standards relevant to glass and architectural glazing that specify the minimum compliance requirements. Historically and related to the market introduction of laminated safety glass based on

Trosifol® PVB interlayer the standards in Europe, North America, Japan and Australia were introduced firstly. In European market laminated safety glass is governed by the basic standard EN ISO 12543 as listed in the table below:

Standard EN ISO 12543

Standard	Description
EN ISO 12543: 2021 - part 1	Glass in building; Laminated glass and laminated safety glass: Definitions and descriptions of components
EN ISO 12543: 2021 - part 2	Glass in building; Laminated glass and laminated safety glass: Laminated safety glass
EN ISO 12543: 2021 - part 4	Glass in building; Laminated glass and laminated safety glass: Test methods for durability
EN ISO 12543: 2021 - part 5	Glass in building; Laminated glass and laminated safety glass: Dimensions and edge finishing
EN ISO 12543: 2021 - part 6	Glass in building; Laminated glass and laminated safety glass: Appearance

TAB 16 •

Next to this general standard there are a lot of other European glazing standards partly referring on EN ISO 12543. They are also listed in ascending numbering.

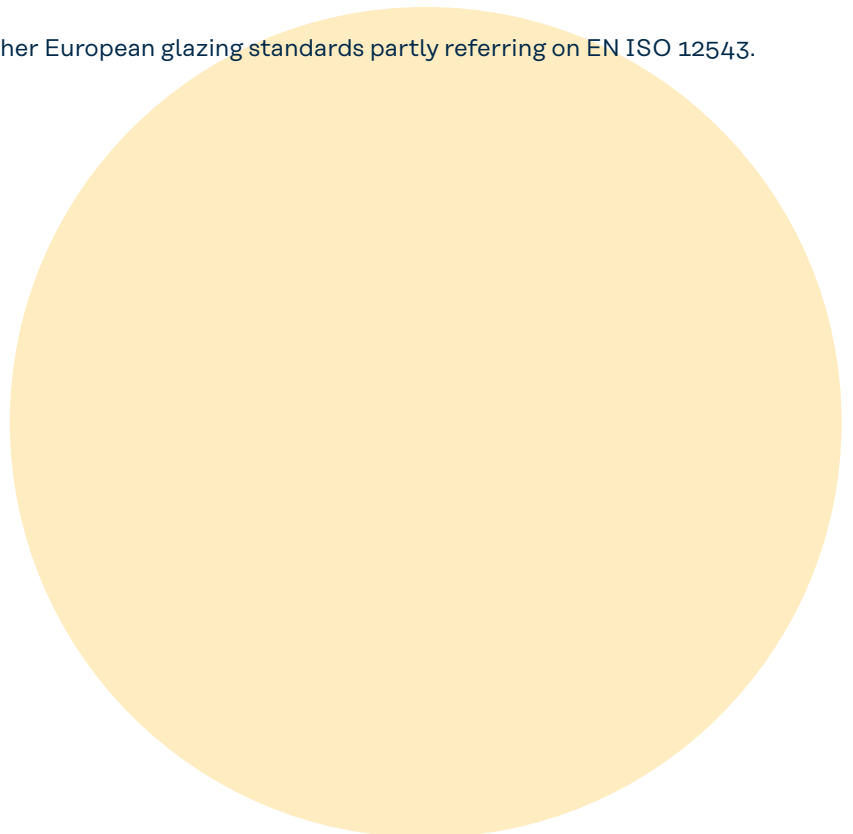

European LSG standards

Standard	Description
EN ISO 140	Acoustics; Measurement of sound-insulation in buildings and of building elements
DIN EN 356	Glass in building; Security Glazing – Testing and classification of resistance against manual attack
EN 410	Glass in building; Determination of luminous and solar characteristics of glazing
EN 1063	Glass in building; Security glazing – Testing and classification of resistance against bullet attack
EN 1522	Windows, doors, shutters and blinds – Bullet resistance – Requirements and classification
EN 1523	Windows, doors, shutters and blinds – Bullet resistance – Test method
EN 12600	Glass in building; Pendulum test – Impact test method and classification for flat glass
EN 12758	Glass in building; Glazing and airborne sound insulation – Product descriptions and determination of properties
EN 13123	Windows, doors & shutters – Explosion resistance; requirements and classification
EN 13541	Glass in building; Security glazing – Testing and classification of resistance against explosion pressure
EN 14449	Glass in building; Laminated glass and laminated safety glass – evaluation of conformity/ product standard
EN 16612	Glass in building – Determination of the lateral load resistance of glass panes by calculation
EN 16613	Glass in building – Laminated glass and laminated safety glass – Determination of interlayer viscoelastic properties
BS 5357	Code of practice for installation of security glazing
BS 6206	Specification for impact performance requirements for flat safety glass and safety plastics for use in buildings
BS 6262-4	Code for practice for safety related to human impact
DIN 12354	Building acoustics – Estimation of acoustic performance of buildings from the performance of elements, Part 1-4
DIN 18008	Glass in building – Design and construction rules, Part 1-5
EN 20140-3	Acoustics; Measurement of sound insulation in buildings and of building components
DIN 52308	Boil test on laminated glass
DIN 52338	Test methods for flat glass in building – Ball drop test for laminated glass

The glazing standards developed in North America (USA and Canada) have been also adapted in Mexico as well as in other Central and South American countries.

They can be classified for safety, security, resistance to wind debris as well as for structural and acoustic glazing.

American and Canadian LSG standards

Standard	Description
ANSI Z97.1 - 2015	Standard for Glazing Materials Used in Buildings – Safety Performance Specifications and Methods of Test (2009)
CPSC 16 CFR 1201	Consumer Products Safety Commission
CAN/CGSB 12.1-M90	Tempered or Laminated Safety Glass (1990)
ASTM C 1172-19	Standard Specification for Laminated Architectural Flat Glass
ASTM E 90-90 (2016)	Laboratory Measurement of Airborne Sound Transmission Loss of Building Partitions and Elements
ASTM E 413-16	Classification of Rating Sound Insulation
ASTM E 1300-16	Standard Practice for Determining Load Resistance of Glass in Buildings
ASTM E 1332-16	Standard Classification for Determination of Outdoor-Indoor Transmission Class (2016)
ASTM E 1425-14	Standard Practice for Determining the Acoustical Performance of Windows, Doors, Skylight and glazed Wall Systems (2014)
ASTM E 1886-19 & E 1996-20	Standard Test Method and Specification for Windborne Debris
ASTM E 2352-21 & E 2358-17	Standard Test Methods for Performance of Glazing in Permanent Railing Systems, Guards and Balustrades (2016)
ASTM F 1233-08 (2019)	Standard Test Method for Security Glazing Materials and Systems
ASTM F 1641: 1995	Standard Test Method for Measuring Penetration Resistance of Security Glazing using a Pendulum Impactor
ASTM F 1642-204	Standard Test Method for Glazing and Glazing Systems Subject to Air Blast Loadings
ASTM F 2248-19	Standard Practice for Specifying an Equivalent 3-Second Duration Design Loading for Blast Resistant Glazing Fabricated with Laminated Glass (2019)
GSA/ISC TS 01	Standard Test Method for Glazing and Window Systems Subject to Dynamic Overpressure Loadings (2003)
NIJ 0108.01	Ballistic Resistant Protective Materials (1985)
SBCCI SSTD 12	Test Standard for Determining the Impact Resistance from Windborne Debris (1997)
UL 972 (2006)	Burglary Resistant Glazing Materials
UL 752 (2015)	Standard for Safety Bullet-Resisting Equipment
GANA	Laminated Glass Design Guide

LSG standards Asia Pacific

Country	Standard	Description
Japan	JIS R 3205: 2005	Laminated Glass
China	GB 9656	Safety technical specification for glazing materials used in power-driven vehicles > for automotive application.
China	GB 15763.3	Safety glass for buildings – part 3: laminated glass > for automotive application.
Australia	AS 1288: 2021	Glazing in buildings – Selection and installation.
Australia	AS 2080:2019	Safety glazing for land vehicles
Australia/ New Zealand	AZ/NZS 2208: 1996	Safety Glazing Materials in Buildings
New Zealand	NZS 4223.3:2016	Glazing in buildings. Part3: Human impact safety requirements.
India	IS 2553-01: 2018	Safety glass specification: part 1 architectural, building and general uses
	IS 2553 Part 2 (2018)	Safety Glass Specification: Road Transport
	IS 2553 Part 3 (2018)	Safety Glass Specification: Solar Applications
	IS 16231 Part 1: 2019	Use of Glass in Buildings – Code of Practice (General Methodology for Selection)
	IS 16231 Part 2: 2019	Use of Glass in Buildings – Code of Practice (Energy & Light)
	IS 16231 Part 3: 2019	Use of Glass in Buildings – Code of Practice (Fire & Loading)
	IS 16231 Part 4: 2019	Use of Glass in Buildings – Code of Practice (Safety Related to Human Impact)
	IS 17004 Part 4: 2018	Testing Methods for Processed Glass
	IS 16978 Part 1: 2018	Glass in Buildings – Forced Entry Security Glazing (Test & Classification by Repetitive Ball Drop)
	IS 16978 Part 1: 2018	Glass in Buildings – Forced Entry Security Glazing (Test Classification by Repetitive Impact of a Hammer & Axe at Room Temperature)
	IS 16978 Part 1: 2018	Glass in Buildings – Forced Entry Security Glazing (Test and Classification by Pendulum Impact Under Thermally and Fire Stressed Conditions)
Thailand	TIS 1222-2560 (2017)	Laminated safety glass
	TIS 2602-2556 (2013)	Automotive Standard: Safety glazing materials for vehicles
Korea	KS L 2004: 2019	Laminated Glass

TAB 19 •

Global ISO Glazing Standards

Standard	Description
ISO 9050	Glass in Building – Determination of light transmittance, solar direct transmittance, total solar energy transmittance and ultraviolet transmittance
ISO 16932	Destructive windstorm-resistant security glazing – Test and Classification Glass in building
ISO 16933	Glass in building – Explosion-resistant security glazing – Test and classification for arena air-blast loading
ISO 16934	Explosion resistant security glazing – Test and classification by shock tube loading
ISO 16935	Glass in building; Bullet resistant security glazing – Test and classification
ISO 16936	Glass in building – Forced-entry security glazing, Part 1-4
ISO 16940	Glass in building – Glazing and Airborne Sound Insulation- Measurement of the Mechanical Impedance of Laminated Glass
ISO 29584	Glass in building – Pendulum Impact Testing and Classification of Safety Glass

TAB 20 •

5.2. Laminated safety glass resistance categories

For laminated safety glass (LSG) with Trosifol® PVB interlayer different categories are defined to differentiate from single pane tempered or heat-strengthened glass. All of them are defined as "Safety glass", but only LSG possesses the characteristic property after an external impact to reduce the risk of injury of a human being in the event of a fracture.

Other main LSG properties like solar, sound, structural and design properties are discussed in other chapters of this manual.

THE 2 MAIN CATEGORIES ARE:

- Passive safety
- Security (active safety)

5.2.1. (PASSIVE) AND ACTIVE SAFETY

In practice a distinction is made between passive and security (active safety); for this purpose different types of glass can generally be used.

5.2.1.1. PASSIVE SAFETY

Passive safety involves providing protection against injury by the glazing itself. Typical application for this injury-reducing glazing are glass doors, partition walls, stairwell, vestibules, table tops, overhead- and floor glazing etc. Sloping, roof or overhead glazing refers to single laminated or to insulating glazing containing minimum one pane of LSG (inside because of fall-preventing properties) that is installed with an inclination of more than 10° from the vertical. Depending of a variety of factors like dimensions and frame-supporting mounting, it is essential in case of sloping glazing that in the event of glass fracturing, individual glass pieces or even entire glass elements cannot fall down and injure people. Balustrade glazing used in stairway or grandstand, façade and balcony areas have to meet specific safety requirements. In particular, they should prevent anyone from injuring themselves or falling out of framing or fixing elements. Glazing in sports facilities like school sport or public arenas generally require resistance to ball impact as well as injury reduction, which is best fulfilled by the use of laminated safety glass.

5.2.1.2. SECURITY (ACTIVE SAFETY)

Security or active safety involves protection by the glazing against any external attack, by so-called attack-resistant glass.

THEY ARE INTENDED TO PROVIDE PROTECTION AGAINST:

- Thrown objects (e.g. attack with a stone etc.)
- Break-in or break-out and penetration
- Attack with firearms
- Attack by explosion pressure (blast)

In most cases, glass test in accordance with the global and regional standards is used in practice as attack-resistant or security glazing. The tools for the attack to the glazed and mostly framed/fixed unit can also be divided into the following categories:

CATEGORIES

- Blunt tool attack (simulated by a steel ball, pendulum)
- Sharp tool attack (simulated by bullet, arrow)
- Cutting tool attack (simulated by an axe) and
- Blast attack (simulated by explosion compressed air shock wave).

Each tool has his characteristic geometry, weight and - in case of explosion – its wave propagation and destruction pattern, influenced by the force / speed and at least energy level in the moment of impact. This level of energy (or impulse / area) makes is necessary to define minimum glass/PVB thickness to withstand the attack. In the glazing standards the resistance classes are always defined with laminates with annealed glass. As soon as the laminate is changed from annealed with heat-strengthened or tempered glass, the relevant resistance class is changing, although the overall film thickness stays the same.

The main parameter, which governs the strength and attack resistance of the laminated glass, is the thickness of the PVB interlayer. The greater the PVB thickness, the higher the resistance as compared to annealed glass alone. But finally the requested safety property decides which is the best performing LSG make-up for each safety or security glazing class.

The Matrix below shows the comparison of some safety and security properties of a single pane glass vs. a double-pane laminate. As shown only laminated safety glass has the optimum safety performance compared to single

ply glazing. Bullet and blast resistant glazing are not listed here because they request a multi-ply laminate which can consist of different glass type in the make-up.

Comparison safety / security properties vs. glass types in LSG

Glass type	Injury-reducing	Shard-retaining	Resistant to ball impact	Burglar-resistant	Fall-preventing	Residual load-bearing capacity after fracture
Annealed glass						
Fully tempered glass	✓		✓*			
Heat strengthened glass						
LSG made of annealed glass	✓	✓	✓*	✓*	✓*	✓
LSG made of fully tempered glass	✓	✓	✓*		✓**	✓****
LSG made of heat strengthened glass	✓	✓	✓*	✓***	✓*	✓

TAB 21 • ✓ suitable * Observe structure/thickness ** Only when held on 4 sides in the frame *** Only under certain conditions ****Only with SentryGlas® /Trosifol® ES

5.3. Safety performance test of laminated safety glass

By far the most important safety performance test is the pendulum impact test. It is the standard for classifying flat glass products by performance under impact and by mode of breakage. The first standards developed to categorize different safety classes were using a soft swing bag – a lead filled leather ball – which is still in use in American and Asia/Pacific regions according to ANSI Z97.1. In Europe the standard EN 12600 uses a 50 kg pneumatic tyre pendulum swinging from 3 different falling heights.

5.3.1. PENDULUM IMPACT TEST ACCORDING TO EN 12600

The pendulum test to EN 12600 is used to simulate impact stressing and the resultant breakage behaviour of laminated safety glass. A 50 kg double tyre (so-called twin tyre with a tyre pressure of 3.5 bar) suspended from a rope swings from a defined falling height against a 876 x 1938 mm size pane of glass mounted in a frame.

The test distinguishes between three classes according to the falling height of the twin tyres.



Safety classes according to EN 12600

Classification	Mode of breakage types	Drop height [mm]
3	A, B, C	190
2	A, B, C	450
1	A, B, C	1200

TAB 22 •

The left column is the drop height class at which the glass did not break or where it broke in accordance with the 2 types of breakage as follows:

TYPES OF BREAKAGE

- Numerous cracks appear, but no shear or opening that allows 76 mm sphere to pass through when a maximum force of 25 N is applied. Additionally, if particles are detached from the test piece up to 3 minutes after impact, they shall weigh no more than a mass equivalent to 10,000 mm² of the original test piece.
- Disintegration occurs and the 10 largest crack free particles are collected within 3 minutes and weigh no more than a mass equivalent to 6,500 mm² of the original test piece.

The second column is the mode of breakage defined as:

MODES OF BREAKAGE

- Type A: Numerous cracks with many sharp-edged fragments (float glass)
- Type B: Numerous cracks where the fragments are held together and do not disintegrate (laminated glass)
- Type C: Disintegration into a large number of relatively small fragments (toughened glass)

The right column is the drop height at which the product did not break or when it broke in accordance with the classification described above in the classification.

Classification of the pendulum test to DIN EN 12600

Classification	Falling height [mm]	Example of LSG assembly Trosifol® Clear*	Example of LSG assembly Trosifol® UltraClear*
3(B)3	190	33.1	33.2, 44.2
2(B)2	450	33.1, 44.1, 44.2	44.2
1(B)1	1200	33.2, 44.2	44.2

TAB 23 • * LSG assembly with annealed glass and Trosifol® Clear (reduced glass adhesion)

5.3.2. PENDULUM IMPACT TEST ACCORDING TO ANSI Z.97.1

The pendulum impact test according to the US standard ANSI Z97.1 operates with a different impact tool, namely a lead filled shot bag with 45 kg (100 lb) mass, at slightly different falling heights. The sample size is 1930 x 864 mm (96" x 34"), and up to 12 samples are used to determine the relevant safety class. Samples which are not broken at a given falling height, might be re-used for the next higher impact level. Also climate exposed samples are measured according to the ANSI standard. The defined drop height classes are:

Drop height classes

Class A	Class B
Glazing material that complies with the requirement when tested at a drop height between 1219 mm and 1232 mm	Glazing material that complies with the requirement when tested at a drop height between 457 mm and 470 mm

TAB 24

A glazing material shall be judged to pass if one of below described criteria is met:

PASSING CRITERIA

- When breakage occurs with the appearance of numerous cracks and fissures, but remains substantially in one piece and no shear, tear or opening occurs within the tested specimen through which a 3" (76 mm) diameter sphere can pass using a horizontally applied force of 4.0 lb. (18 N) or less.
- When breakage occurs, the crack-free particles shall weigh no more than the equivalent weight of 100 cm² of the original specimen.

5.4. Security performance test of laminated safety glass

For glazing providing resistance to manual attack, the following security properties can be achieved with Trosifol® PVB interlayer based laminated safety glass:

SECURITY PROPERTIES

- **Impact resistant glazing**
Protection from forced entry or vandalism
- **Penetration resistant glazing**
Resistance to hand-held impact bodies
- **Bullet-proof glazing**
Resistance to bullets/firearm projectiles
- **Blast-resistant glazing**
Resistance to explosions/shock waves

For each of these security classes both the European and the American standards are described. Target of each standard is to determine the minimum glass/PVB thickness with laminates on the base of annealed glass. The first two above listed security classes are mostly fulfilled with single ply laminates and one layer of PVB (except burglary proof glazing/axe test). The other security classes can only be fulfilled with multi ply laminates with minimum 3 plies and 2 PVB layers.

5.4.1. IMPACT RESISTANT GLAZING/BALL DROP TEST

To define the minimum requirement of a laminated safety glass, a so called ball-drop test was adapted from the Automotive glazing standard which simulated the impact of a stone onto a car windscreen in the 1970ties also for the architectural glass industry. The first standard was the German norm DIN 52338.

5.4.1.1. BALL DROP TEST ACCORDING TO DIN 52338

This test simulates the hard impact of a falling stone of low weight and relative high speed onto a glass roof. The main conditions of this ball drop test are:

MAIN CONDITIONS OF BALL DROP TEST

- Steel ball of 1030 g (2.27 lb.)
- Center punch on framed glass sample, only one hit per sample
- Minimum falling height 4 m (15.75''), Impact energy 40 Joule
- Test at room temperature 23°C (73°F)
- 3 samples of each laminate type
- Test is passed if the steel ball doesn't penetrate the glass



Passed



Not passed

5.4.1.2. AXE TEST ACC. TO EN 356 CONDITIONS

Impact resistant safety glass provides protection from burglary and vandalism in buildings. The standard EN 356 specifies the requirements and test methods for glass designed to be resistant against manual attack. The test has the following set-up:

TEST SET-UP BURGLARY PROOF GLAZING (EN 356)

- Steel ball of 4.11 kg (9 lb) weight, diameter 10 cm (4")
- Test sample size 900 x 1100 mm (35,4" x 43,3")
- Sample framed 4 sided
- 3 balls hit in a triangle
- Test temperature: 23°C (73°F)
- 5 classes with different drop heights (P1A to P5A, see table)

The test is passed if none of the 3 balls in an triangle shape penetrates the glass. The following table shows the summary of the resistance classes and the minimum LSG composition (based on annealed glass) that fulfills the requirement.



Classification of impact resistance

Standard	Class of resistance	Drop height [mm]	Number of strikes in triangle shape	LSG with Trosifol® Clear
EN 356	P1A	1500	3	33.2, 44.2
	P2A	3000	3	33.4/44.2*/44.3
	P3A	6000	3	44.3
	P4A	9000	3	44.4
	P5A	9000	3 x 3	44.6

5.4.1.3. BURGLARY PROOF GLAZING ACCORDING TO UL 972

Similar to the above described EN 356 the American standard UL 972 describes the impact resistance of burglary proof glazing by using the ball drop test. This test method subjects the glazing sample to withstand a number of strikes from a single steel ball dropping vertically from different heights. The conditions are:

TEST SET-UP BURGLARY PROOF GLAZING (UL 972)

- Steel ball 5 lb. (2.26 kg)
- Ball diameter 3-1/4" (82 mm)
- Test sample size 24" x 24" (610 x 610 mm)
- Sample framed 4 sided
- 10 samples per type
- Different test temperatures (as in the table below)

The test is passed if minimum 9 of the 10 tested samples are not penetrated by all 5 hits of the steel ball (for indoor use application, for others different).

1. Test conditions as listed above.
2. The steel ball shall not penetrate the laminate on any 5 impacts for 9 of the 10 samples tested.
3. The steel ball shall not penetrate the laminate on any of the 3 samples tested.

A typical 2 ply-laminate to pass the UL 972 ball drop test requirements is a 1/4 inch (6 mm) thick laminated glass with the make-up 3 mm / 0.030" PVB / 3 mm and Trosifol® Clear as interlayer.

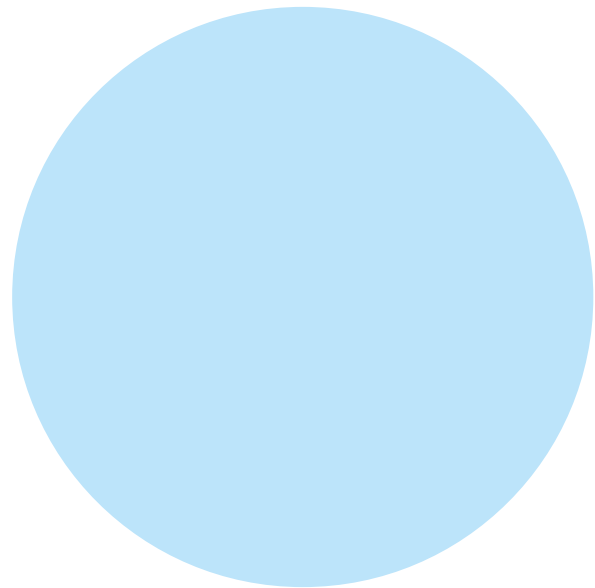

Test requirements burglary resistant glazing material

UL 972 tests	Impacts per sample	Impact energy [joules]	Impact energy [ft – lbs]	Temperature [°C]	Temperature [°F]
Multiple impact	5	68	50	21-27	70-80
Outdoor use	5	54	40	-10	14
Indoor use	5	54	40	49	120
	5	68	50	35	95
High energy impact	5	68	50	13	55
	1	271	200	21-27	70-80

5.4.2. BURGLARY PROOF GLAZING ACCORDING TO EN 356 (AXE TEST)

In connection with protection from forced entry and vandalism, reference is made to burglar-resistant glazing, where the classification, based on a penetration test with a cutting implement, assumes an attack with maximum energy.

Tests of penetration-resistant glazing against attack with a cutting tool in conformity with EN 356 are carried out with an axe machine that simulates attack with a hand-held axe weighing 2 kg. The test establishes the number of impacts required to produce a 400 x 400 mm hole in a 900 x 1100 mm test specimen. The machine swings the axe at a velocity of approx. 11 m/s and generates impact energy of approx. 300 J.

The above described impact tests for burglary-proof glazing are also part of the international standard ISO 16936 with the title "Forced-entry security glazing". In part 1 of this standard the repetitive ball drop, in part 2 the impact test by hammer and axe is defined and classified.



REQUIREMENTS EXPECTED OF PENETRATION-RESISTANT LSG

- Must achieve the longest possible resistance time to repeated assault with simple or complex implements in the maximum time for attack available
- Best-possible protection with the laminated glass chosen on the basis of the expected performance features, the value of the objects in need of protection and the foreseeable action time in the event of vandalism and forced entry
- Its frame design and installation must afford the maximum possible protection.

Test requirements burglary proof glazing according EN 356

Category of resistance	Hammer strikes		Cutting strikes		Total number of strikes
	Impact velocity [m/s]	Impact energy [N/m]	Impact velocity [m/s]	Impact energy [N/m]	
P6B	12,5	350	11	300	30 - 50
P7B	12,5	350	11	300	51 - 70
P8B	12,5	350	11	300	> 70

TAB 27 •

EN356 performance levels by construction

EN 356	Level	SentryGlas® ionoplast	SentryGlas® Xtra™ ionoplast	Trosifol® PVB
Ball drop test	P1A	3 mm (1/8") 0.89 mm (35 mil) 3 mm (1/8")	3 mm (1/8") 0.76 mm (30 mil) 3 mm (1/8")	3 mm (1/8") 0.76 mm (0.30 mil)* 3 mm (1/8")
	P2A	4 mm (5/32") 1.52 mm (60 mil) 4 mm (5/32")	4 mm (5/32") 1.52 mm (60 mil) 4 mm (5/32")	4 mm (5/32") 0.76 mm (0.30 mil)* 4 mm (5/32")
	P3A	4 mm (5/32") 1.52 mm (60 mil) 4 mm (5/32")	4 mm (5/32") 1.52 mm (60 mil) 4 mm (5/32")	4 mm (5/32") 1.14 mm (45 mil) 4 mm (5/32")
	P4A	4 mm (5/32") 2.28 mm (90 mil) 4 mm (5/32")		4 mm (5/32") 1.52 mm (60 mil) 4 mm (5/32")
	P5A	4 mm (5/32") 3.04 mm (120 mil) 4 mm (5/32")		4 mm (5/32") 2.28 mm (90 mil) 4 mm (5/32")
Axe test	P6B	4 mm (5/32") 3.04 mm (120 mil) 4 mm (5/32")	4 mm (5/32") 3.04 mm (120 mil) 4 mm (5/32")	3 mm (1/8") 1.52 mm (60 mil) 10 mm (3/8") 2.28 mm (90 mil) 5 mm (3/16")
	P7B	4 mm (5/32") 3.04 mm (120 mil) 4 mm (5/32")		4 mm (5/32") 0.76 mm (30 mil) 8 mm (5/16") 0.76 mm (30 mil) 5 mm (3/16") 0.76 mm (30 mil) 3 mm (1/8")
	P8B	4 mm (5/32") 2.28 mm (90 mil) 4 mm (5/32") 2.28 mm (90 mil) 4 mm (5/32") or 4 mm (5/32") 4.56 mm (180 mil) 4 mm (5/32")	4 mm (5/32") 2.28 mm (90 mil) 4 mm (5/32") 2.28 mm (90 mil) 4 mm (5/32") or 4 mm (5/32") 4.56 mm (180 mil) 4 mm (5/32")	4 mm (5/32") 0.76 mm (30 mil) 6 mm (1/4") 0.76 mm (30 mil) 5 mm (3/16") 0.76 mm (30 mil) 6 mm (1/4") 0.76 mm (30 mil) 4 mm (5/32")

TAB 28 • * not valid for Trosifol® UltraClear

5.4.3. FORCED-ENTRY SECURITY TESTS IN USA

Beside the described US standard security tests some other test procedures are described to evaluate glazing performance in the medium and high security glazing section. One is the H.P. White Laboratories Test Procedure HPW-TP-0500.03. The other is the WMFL Procedure, which is referring on ASTM F 1233 standard which describes both forced-entry and ballistic glazing performance. A detailed description will not be given here; a good reference is the NGA Laminated Glazing Reference manual in the latest issue published in 2019.

5.4.4. BULLET-PROOF GLAZING

The next higher level of security of glass is the resistance against ballistic attack. The standards specify the performance requirements and test methods for the classification of bullet-resistant glass, based on attack by handguns, rifles and shotguns. The make-up of the laminate is a multi-ply composition of layered glass and PVB interlayer.

For confidential and safety reason only the total thickness of laminate is published, not the details of the glass make-up which is part of the laminator's know-how. In Europe the ballistic attack on safety glass is described in the standard EN 1063, in USA bullet-resistant glazing is tested in accordance with either the method described in ASTM F1233 or the requirements of Underwriter's Laboratories test UL 752.

5.4.4.1. BULLET PROOF GLAZING STANDARD EN 1063 (EU)

Glazing is considered bullet-proof if it prevents the passage of various ammunition projectiles and satisfies EN 1063. Several layers of Trosifol® film are combined with glass plies of differing thickness to produce bullet-proof glass. Testing involves firing three bullets at the glazing at fixed distances apart at a test temperature of $18^{\circ}\text{C} \pm 5^{\circ}\text{C}$. The resistance categories differ according to the bullet calibre. A distinction is made between "No Splinters" (NS) and "Splinters" (S). The fragments are collected on a sheet of aluminium foil suspended 500 mm behind the test target. The resistance categories of the two standards are compared in the subsequent table.

Classification of bullet-proof glazing to EN 1063

Calibre	Bullet type*	Bullet mass [g]	Firing class Splinters	Firing class No splinters	Firing distance [m]	Velocity [m/s]
22 LR	URN	2.6±0.10	BR1-S	BR1-NS	10±0.5	360±10
9 x 19 mm	VMR/Wk	8.0±0.10	BR2-S	BR2-NS	5±0.5	400±10
357 Magnum	VMKS/Wk	10.25±0.10	BR3-S	BR3-NS	5±0.5	430±10
44 Magnum	VMF/Wk	15.55±0.10	BR4-S	BR4-NS	5±0.5	440±10
5.56 x 45 mm	FJ/PB/SCP1	4.0±0.10	BR5-S	BR5-NS	10±0.5	950±10
7.62 x 51 mm	VMS/Wk	9.45±0.10	BR6-S	BR6-NS	10±0.5	830±10
7.62 x 51 mm	VMS/Hk	9.75±0.10	BR7-S	BR7-NS	10±0.5	820±10
Shotgun 12/70	Brenneke	31.0±0.50	SG1-S**	SG1-NS**	10±0.5	420±20
Shotgun 12/70	Brenneke	31.0±0.50	SG2-S	SG2-NS	10±0.5	420±20

TAB 29 • * FJ: Full metal jacket bullet
L: Lead
PB: Pointed bullet
RN: Round nose
SCP1: Soft core and steel penetrator

VMF/Wk: Full metal jacket flat nose bullet with soft core
VMKS/Wk: Full metal jacket, conical tip bullet with soft core
VMR/Wk: Full metal jacket, round nose bullet with soft core
VMS/Hk: Full metal jacket, pointed bullet with hard core
VMS/Wk: Full metal jacket, pointed bullet with soft core

** Test carried out with single shot fired

The resistance categories BR1 to BR7 refer to laminated safety glazing in increasing thicknesses. The assembly tested for a certain category automatically satisfies the requirements of the lower categories. If the test is carried out in an enclosed room, the test temperature is 18°C . For tests outdoors, the temperature is not defined by the standard, but is decided upon by the tester after prior consultation with the client.

Bullet-proof glass is installed, for instance, in banks, military installations and government, judiciary and commercial buildings. Non-splintering bullet-proof glazing is used where, in extreme cases, people may be right behind the glazing.

All bullet-proof glazing composed of several asymmetrical layers of laminated safety glass inevitably provides a higher standard of burglary resistance. Recommendations for possible glass assemblies can be obtained from Trosifol® Technical Service. The American standard ASTM F 1233 applies to different weapons/calibres and provides a different classification from that given in EN 1063 (see table on page 94).



TEST PROCEDURE ACC. EN 1063 FOR THE CLASSIFICATION OF BULLET RESISTANT GLASS

- Target: to determine the resistance of a glazing against certain levels of attack, always 3 strikes
- 2 types of classification:
 - a) no perforation of the glazing by the bullet or parts of the bullet and no perforation of the witness foil by glass splinters from the rear face (no splinters)
 - b) no perforation of the glazing by the bullet or parts of the bullet, but with perforation of the witness foil by glass splinters from the protected face (splinters)

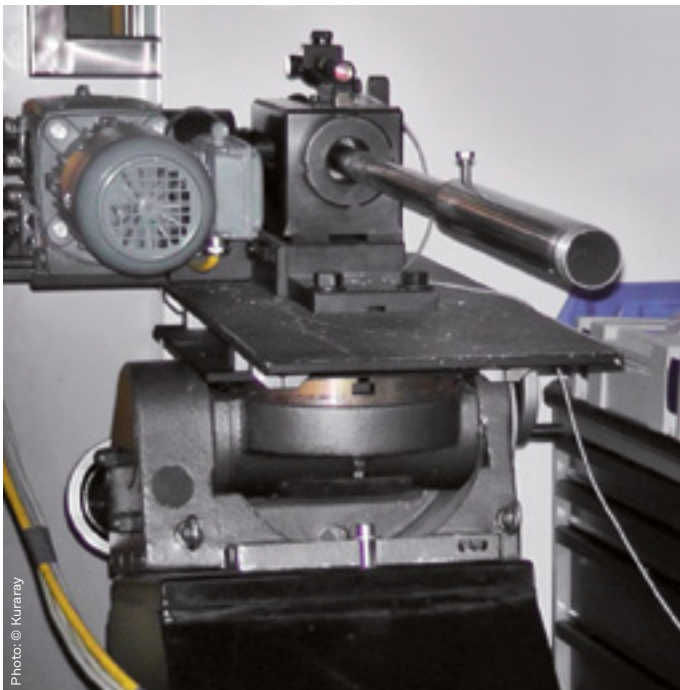

➔ Passed



➔ Not passed

Examples of bullet-resistant assemblies to EN 1063*

Class	Calibre	Total thickness S/NS [mm]	Glass plies S	Layers of PVB S	Layers of glass NS	Layers of PVB NS
BR 1	0.22 LR	13/18	2	1	2	1
BR 2	9 mm Luger	20/28	3	2	4	3
BR 3	0.357 Magnum	24/38	4	3	5	4
BR 4	0.44 Magnum	29/45	4	3	6	5
BR 5	5.56 x 45	36/54	5	4	7	6
BR 6	7.62 x 51	45/68	5	4	8	7
BR 7	7.62 x 51	70/82	8	7	8	7
SG 1	Cal. 12/70	33/54	5	4	6	5
SG 2	Cal. 12/70	42/68	5	4	8	7

TAB 30 • * List of published assemblies; these have not been tested by Trosifol®

The resistance categories BR1 to BR7 refer to laminated safety glazing in increasing thicknesses. The assembly tested for a certain category automatically satisfies the requirements of the lower categories. If the test is carried out in an enclosed room, the test temperature is 18°C. For tests outdoors, the temperature is not defined by the standard, but is decided upon by the tester after prior consultation with the client.

Bullet resistant configurations that comply with two of the EN 1063 standard threat levels are shown below:

European standard EN 1063

Threat level	Ammu- nition	Required velocity		Composition	Thickness		Weight		Number of shots
		[mps]	[fps]		[mm]	[in]	[kg/m ²]	[lbs/ft ²]	
BR 4 NS	0.44 Magnum	430- 450	1411- 1476	6 mm (¼") Annealed glass/ 0.9 mm (35 mil) SentryGlas®/ 6 mm (¼") Annealed glass/ 5 mm (⅜") SentryGlas®/ 2.5 mm (⅜") Annealed glass/ 1.52 mm (60 mil) Trosifol® UltraClear/ 0.18 mm (7 mil) Trosifol® Spallshield® CPET	21.3	0.84	41.72	8.5	3
BR 6 NS	7.62 x 51 mm (M80)	820- 840	2690- 2755	8 mm (⅝") Annealed glass/ 0.76 (30 mil) mm Trosifol® Clear/ 8 mm (⅝") Annealed glass/ 0.76 mm (30 mil) Trosifol® Clear/ 8 mm (⅝") Annealed glass/ 0.76 mm (30 mil) Trosifol® Clear/ 6 mm (¼") Annealed glass/ 5 mm (⅜") SentryGlas®/ 2.5 mm (⅜") Annealed glass/ 1.52 mm (60 mil) Trosifol® UltraClear/ 0.18 mm (7 mil) Trosifol® Spallshield® CPET	39.5	1.55	85.92	17.6	3

TAB 31 •

SentryGlas® Xtra™ (SGX) constructions

Threat level	Ammunition	Required velocity		Composition	Thickness		Weight		Number of shots
		[mps]	[fps]		[mm]	[in]	[kg/m ²]	[lbs/ft ²]	
BR 4 NS	0.44 Magnum	430- 450	1411- 1476	6 mm (¼") Annealed glass/ 0.9 mm (35 mil) SentryGlas® Xtra™/ 6 mm (¼") Annealed glass/ 5 mm (⅜") SentryGlas® Xtra™/ 2.5 mm (⅜") Annealed glass/ 1.52 mm (60 mil) Trosifol® UltraClear/ 0.18 mm (7 mil) Trosifol® Spallshield® CPET	21.3	0.84	41.72	8.5	3
BR 6 NS	7.62 mm x 51 mm (M80)	820- 840	2690- 2755	8 mm (⅝") Annealed glass/ 0.9 mm (35 mil) SentryGlas® Xtra™/ 8 mm (⅝") Annealed glass/ 0.9 mm (35 mil) SentryGlas® Xtra™/ 8 mm (⅝") Annealed glass/ 0.9 mm (35 mil) SentryGlas® Xtra™/ 6 mm (¼") Annealed glass/ 5 mm (⅜") SentryGlas® Xtra™/ 2.5 mm (⅜") Annealed glass/ 1.52 mm (60 mil) Trosifol® UltraClear/ 0.18 mm (7 mil) Trosifol® Spallshield® CPET	41.4	1.63	87.39	17.9	3
BR 6 NS	7.62 mm x 51 mm (M80)	820- 840	2690- 2755	8 mm (⅝") Annealed glass/ 0.76 mm (30 mil) Trosifol® PVB/ 8 mm (⅝") Annealed glass/ 0.76 mm (30 mil) Trosifol® PVB/ 8 mm (⅝") Annealed glass/ 0.76 mm (30 mil) Trosifol® PVB/ 6 mm (¼") Annealed glass/ 5 mm (⅜") SentryGlas® Xtra™/ 2.5 mm (⅜") Annealed glass/ 1.52 mm (60 mil) Trosifol® UltraClear/ 0.18 mm (7 mil) Trosifol® Spallshield® CPET	39.5	1.55	85.92	17.6	3

TAB 32 •

5.4.4.1. AMERICAN BULLET RESISTANT GLAZING STANDARDS

Bullet resistant laminated safety glass for ballistic ratings in USA is tested according to different standards and regulations. Mainly these are:

US STANDARDS AND REGULATIONS FOR BULLET RESISTANT LSG

- ASTM F 1233
- Underwriters Laboratories Standard UL 752
- National institute of Justice (NIJ) Standard O108.1
- HP White Laboratories test HPW-TP-0500.02

In case of all-glass-laminates multi-ply compositions with PVB (or Ionoplast) interlayer are necessary to prevent bullet penetration. Typical laminate thickness begins at 1 ¼ inches (32 mm) and is available up to 3 inches (76 mm) thick. All laminates have to provide an improved safety barrier against bullets and related flying fragments or glass pieces (spall). The all-glass laminates performance covers the low to mid-range of ballistic performance. In order to achieve higher ballistic performance ranges, multi-ply glass and plastic (e.g. Polycarbonate PC) combinations are used, where glass/glass contact is made with Trosifol® PVB and PC/glass or PC/PC contacts are made with SentryGlas® Ionoplast or interlayers other than PVB.

The following tables show the ballistic performance levels of bullet resistant glazing according to the first two above listed standards ASTM F 1233 and UL 752.

Bullet resistant configurations that have been tested and found to comply with commonly specified Indoor UL Standard threat levels are shown below:

Indoor UL 752 Standard for Bullet Resisting Equipment

Threat level	Ammunition	Nominal bullet mass		Required velocity		Composition	Thickness		Weight		Number of shots
		[g]	[grains]	[mps]	[fps]		[mm]	[in]	[kg/m ²]	[lbs/ft ²]	
1	9 mm full metal copper jacket with lead core	8.0	124	358-394	1175-1293	6 mm (¼") Annealed glass/ 0.9 mm (35 mil) SentryGlas®/ 6 mm (¼") Annealed glass/ 4.5 mm (177 mil) SentryGlas®/ 3 mm (⅛") Annealed glass/ 0.76 mm (30 mil) Trosifol® UltraClear/ 0.18 mm (7 mil) Trosifol® Spallshield® CPET	21.6	0.85	44.24	9.1	3
2	0.357 Magnum jacketed lead soft point	10.2	158	381-419	1250-1375	3 mm (⅛") Annealed glass/ 0.9 mm (35 mil) SentryGlas®/ 5 mm (⅜") Annealed glass/ 0.9 mm (35 mil) SentryGlas®/ 5 mm (⅜") Annealed glass/ 4.5 mm (177 mil) SentryGlas®/ 3 mm (⅛") Annealed glass/ 0.76 mm (30 mil) Trosifol® UltraClear/ 0.18 mm (7 mil) Trosifol® Spallshield® CPET	22.4	0.88	44.78	9.17	3
3	0.44 Magnum, lead semi-wadcutter gas checked	15.6	240	411-441	1350-1447	4 mm (⅝") Annealed glass/ 0.9 mm (35 mil) SentryGlas®/ 6 mm (¼") Annealed glass/ 0.9 mm (35 mil) SentryGlas®/ 6 mm (¼") Annealed glass/ 4.5 mm (177 mil) SentryGlas®/ 3 mm (⅛") Annealed glass/ 0.76 mm (30 mil) Trosifol® UltraClear/ 0.18 mm (7 mil) Trosifol® Spallshield® CPET	25.4	1.00	52.20	10.7	3
4	0.30-60 caliber rifle lead core soft point	11.7	180	774-852	2540-2794	8 mm (⅝") Annealed glass/ 0.76 mm (30 mil) Trosifol® Clear/ 10 mm (⅜") Annealed glass/ 0.76 mm (30 mil) Trosifol® Clear/ 8 mm (⅝") Annealed glass/ 5 mm (⅜") SentryGlas®/ 3 mm (⅛") Annealed glass/ 0.76 mm (30 mil) Trosifol® UltraClear/ 0.18 mm (7 mil) Trosifol® Spallshield® CPET	36.4	1.43	79.63	16.3	1
5	7.62 mm rifle lead core full metal copper jacket, military ball	9.7	150	838-922	2750-3025	8 mm (⅝") Annealed glass/ 0.76 mm (30 mil) Trosifol® Clear/ 10 mm (⅜") Annealed glass/ 0.76 mm (30 mil) Trosifol® Clear/ 8 mm (⅝") Annealed glass/ 5 mm (⅜") SentryGlas®/ 3 mm (⅛") Annealed glass/ 0.76 mm (30 mil) Trosifol® UltraClear/ 0.18 mm (7 mil) Trosifol® Spallshield® CPET	36.2	1.43	78.67	16.1	1
6	9 mm full metal copper jacket with lead core	8.0	124	427-469	1400-1540	8 mm (⅝") Annealed glass/ 0.76 mm (30 mil) Trosifol® Clear/ 10 mm (⅜") Annealed glass/ 0.76 mm (30 mil) Trosifol® Clear/ 8 mm (⅝") Annealed glass/ 5 mm (⅜") SentryGlas®/ 3 mm (⅛") Annealed glass/ 0.76 mm (30 mil) Trosifol® UltraClear/ 0.18 mm (7 mil) Trosifol® Spallshield® CPET	36.5	1.44	79.42	16.3	5



Bullet resistant configurations that comply with several of the NIJ Standard threat levels are shown below:

NIJ 0108.01 Ballistic Protective Glazing Materials

Threat level	Ammunition	Nominal bullet mass		Required velocity		Composition	Thickness		Weight		Number of shots
		[g]	[grains]	[mps]	[fps]		[mm]	[in]	[kg/m ²]	[lbs/ft ²]	
I	0.22 long rifle high velocity lead	2.6	40	320±12	1050±40	3 mm (1/8") Annealed glass/ 5 mm (3/16") SentryGlas®/ 2.5 mm (3/32") Annealed glass/ 0.76 mm (30 mil) Trosifol® UltraClear/ 0.18 mm (7 mil) Trosifol® Spallshield® CPET	11.6	0.46	19.92	4.1	5
	0.38 special round nose lead	10.2	158	259±15	850±50						
II-A	0.357 Magnum jacketed soft point	10.2	158	381±15	1250±50	4 mm (5/32") Annealed glass/ 0.9 mm (35 mil) SentryGlas®/ 4 mm (5/32") Annealed glass/ 5 mm (3/16") SentryGlas®/ 2.5 mm (3/32") Annealed glass/ 1.52 mm (60 mil) Trosifol® UltraClear/ 0.18 mm (7 mil) Trosifol® Spallshield® CPET	18	0.71	33.5	6.9	5
	9 mm full metal jacket	8.0	124	332±12	1090±40						
II	0.357 Magnum jacketed soft point	10.2	158	425±15	1395±50	4 mm (5/32") Annealed glass/ 0.9 mm (35 mil) SentryGlas®/ 4 mm (5/32") Annealed glass/ 5 mm (3/16") SentryGlas®/ 2.5 mm (3/32") Annealed glass/ 1.52 mm (60 mil) Trosifol® UltraClear/ 0.18 mm (7 mil) Trosifol® Spallshield® CPET	18	0.71	33.5	6.9	5
	9 mm full metal jacket	8.0	124	358±12	1175±40						
III-A	0.44 Magnum lead semi-wadcutter gas checked	15.5	240	426±15	1400±50	6 mm (1/4") Annealed glass/ 0.9 mm (35 mil) SentryGlas®/ 6 mm (1/4") Annealed glass/ 5 mm (3/16") SentryGlas®/ 2.5 mm (3/32") Annealed glass/ 1.52 mm (60 mil) Trosifol® UltraClear/ 0.18 mm (7 mil) Trosifol® Spallshield® CPET	21.4	0.84	42.2	8.6	5
	9 mm full metal jacket	8.0	124	426±15	1400±50						
III	7.62 mm (.308 Winchester) full metal jacket	9.7	150	838±50	2750±50	2.5 mm (3/32") Annealed glass/ 0.76 mm (30 mil) Trosifol® Clear/ 8 mm (5/16") Annealed glass/ 0.76 (30 mil) mm Trosifol® Clear/ 10 mm (3/8") Annealed glass/ 0.76 (30 mil) mm Trosifol® Clear/ 8 mm (5/16") Annealed glass/ 5 mm (3/16") SentryGlas®/ 2.5 mm (3/32") Annealed glass/ 1.52 mm (60 mil) Trosifol® UltraClear/ 0.18 mm (7 mil) Trosifol® Spallshield® CPET	37.9	1.49	81.2	16.63	5

TAB 34 •

Typical applications for bullet-resistant glazing are military installations, banks, prisons, detention centers, prisons and embassies.



Photo: © futuristman/shutterstock.com

Bullet resistance classification to ASTM F1233

Calibre	Weapon type	Class/level	Bullet mass/type	Velocity [ft./s.]
0.38 Special	Handgun low	HG1	158 gr*	875
0.357 Magnum	Handgun medium	HG2	158 gr*	1400
9 mm	Handgun medium	HG3	124 gr*	1250
0.44 Magnum	Handgun high	HG4	240 gr*	1425
9 mm	Submachine gun	SMG	124 gr*	1450
0.233 (5.56 mm)	Rifle light	R1	55 gr*	3100
0.30-'06	Rifle heavy	R2	180 gr*	2925
0.308 Winchester	Rifle heavy jacketed	R3	147 gr*	2750
0.30-'06	Rifle armor-piercing	R4-AP	164 gr*	2800
12 gauge	Shotgun buckshot	SH1	00 buckshot	1200
12 gauge	Shotgun slug	SH2	1 oz. rifle	1650

TAB 35 • * gr = grain (100 grain = 6.5 grams)

Bullet resistance classification acc. to standard UL 752

Rating	Ammunition	Grain	G	Velocity min/max fps	Velocity min/max mps	Number of shots
Level 1	9 mm Full metal copper jacket with lead core	124	8.0	1175/1293	358/394	3
Level 2	357 Magnum jacketed lead soft point	158	10.2	1250/1375	381/419	3
Level 3	0.44 Magnum lead semi-wadcutter gas checked	240	15.6	1350/1485	411/441	3
Level 4	0.30 Caliber rifle lead core soft point	180	11.7	2450/2794	774/852	1
Level 5	7.62 mm Rifle lead core full metal copper jacket military ball	150	9.7	2750/3025	838/522	1
Level 6	9 mm Full metal copper jacket with lead core	124	8.0	1400/1540	427/469	5
Level 7	5.56 mm Rifle full metal copper jacket with lead core	55	3.56	3080/3388	939/1033	5
Level 8	7.62 mm Rifle lead core full metal copper jacket, military ball	150	9.7	2750/3025	838/922	5
Level 9	Armor-piercing, .30 Caliber rifle steel core lead point filer full metal jacket	166	10.8	2715	828	5
Level 10	0.50 Caliber rifle lead core full metal copper jacket military ball	710	45.9	2910	856	-
Supplementary Shotgun	12-gauge rifled lead slug	437	28.3	1585/1744	483/532	3
	12-gauge 00 lead buckshot (12 pellets)	650	42	1200/1320	366/402	3

TAB 36 • * gr = grain (100 grain = 6.5 grams)

5.5. Hurricane resistant security glazing

5.5.1. INTRODUCTION

The effects of winds in hurricanes are particularly harsh. Turbulent winds can affect a building for hours. These winds change slowly in direction as the storm approaches and passes over a building. Debris can be progressively dislodged from nearby structures, accelerated by sustained winds that can impact all elevated parts of a building. Following impact, the building can be buffeted by sustained and cyclic wind pressures for hours prior to the storm moving away.

Hurricane impact protection of buildings did not exist in the US until the 1994 South Florida building code was established. Miami-Dade County was the first to act on the need for building code requirements that address impact resistant glazing. Since then, states along the Gulf and Atlantic coasts from Texas to Massachusetts have followed suit. As laminated glass is a critical component of glazing systems designed to withstand hurricane-force wind and rain, it is essential that engineers, designers and architects have an understanding of the performance, testing and wide-ranging benefits of various types of laminated glass.

Post-storm investigations by the Miami-Dade County building code Evaluation Task Force determined that the most significant hurricane damage was from the loss of integrity of the building envelope when the exterior of a structure was breached. The primary cause of this property damage was windborne debris traveling at speeds of up to 233 kph (145 mph), which penetrated windows and doors, resulting in many cases, in internal pressurization and ultimately, collapse of the building structure.

As a result of these findings, Miami-Dade County worked with industry representatives to develop requirements that addressed impact protection of building openings that directly applied to windows, doors, skylights, retail storefronts and façade curtain wall systems. The South Florida building code with its hurricane mitigation provisions was implemented in September 1994. In 2002, the improved structural parts of this Code were absorbed into the Florida building code as the 'High Velocity Hurricane Zone' provisions. Building code requirements for impact protection have expanded beyond Florida as states have adopted the International building codes.



5.5.2. WHAT IS HURRICANE RESISTANT SECURITY GLAZING?

Hurricane impact resistant glazing is glass that is capable of resisting violent storms, wind and rain, and the resulting impact forces from flying / windborne debris (large or small missiles) such as roof tiles, gravel, timber, satellite dishes, etc.

It is found in hurricane-prone areas on retail storefronts, offices, private and public buildings. It is used to protect exterior windows and doors primarily, but also skylights, canopies, façades and curtain-wall systems and in some cases, balcony railings on high-rise buildings. Main purpose is to maintain the integrity of the building envelope by resisting the forces of high winds and rain, as well as resisting high impact forces from windborne debris. In addition, secondary considerations are to retain the glass in place if it breaks, providing security and preventing additional debris contribution during the wind event.

5.5.3. TEST REQUIREMENTS AND STANDARDS

Globally, there is a need for a common set of standards relating to hurricane impact resistant glazing for buildings. To date none exist, so many countries or regions of the world are guided by standards established in North America.

TWO STANDARDS ARE USED TO ESTABLISH TESTING PROCEDURES AND PERFORMANCE SPECIFICATION OF HURRICANE IMPACT RESISTANT GLAZING IN NORTH AMERICA:

- ASTM E1886 'Test Method for Exterior Windows, Curtain Walls, Doors, and Impact Protective Systems Impacted by Missile(s) and Exposed to Cyclic Pressure Differentials'.
- ASTM E1996 'Standard Specification for Performance of Exterior Windows, Curtain Walls, Doors, and Storm Shutters Impacted by Windborne Debris in Hurricanes'.

In 2006, ISO published its ISO 16932 Glass in Building – Destructive windstorm resistant security glazing – Test and Classification standard. A working group of international experts participated in the development of this standard. Similar to the ASTM standards, the ISO standard contains methods for large and small missile impact testing, as well as air pressure cycling.

5.5.4. WINDBORNE DEBRIS AND MISSILES

In urban areas, analysis of window damage after hurricanes has shown that pea gravel used for roof ballast is the principle form of small missile debris that causes damage to windows in the upper floors of high rise buildings. Most building codes / specifications, including the ASTM, have adopted 2 gm as the standard size of small missile. To provide integrity to the testing, a 2 g steel ball bearing is used to represent roof gravel in small missile impact testing, and the impactors must be accounted for after the test.

In residential areas, analysis of window damage after hurricanes has shown that timber from wood framed houses is the principal form of large missile debris. Other large missiles include roof tiles and satellite dishes. These types of objects can break windows, penetrate walls and roofs. Local and international building codes will vary from region to region, but the ASTM has adopted a 2 x 4 piece of timber, 2.4 m (8 ft 4 in) in length, weighing 4.1 kg (9 pounds) as the standard Level 'D' large missile to be used in impact tests. Level 'C' and 'E' missiles will have different spec's and impact speeds.



➤ Jennie Sealy Hospital, Galveston/Texas, USA



Photo: © Johnny Milano

➤ House still standing after Hurricane Michael 2018, Mexico Beach, Florida



Photo: © Kuraray

➤ Miami Courthouse, USA



Photo: © Lena Seditova / shutterstock.com

5.5.5. BENEFITS OF LAMINATED GLASS IN HURRICANE APPLICATIONS

Laminated glass, two plies of glass bonded together by an interlayer, can be engineered to provide very high levels of protection from hurricanes and windborne debris. Depending on the location, size of the glass panels and design pressures, the interlayer used in the glass laminate may be of different thicknesses or types. The strength and performance properties of laminated glass can be tailored to meet specific needs.

Laminated safety glass with Trosifol® PVB and SentryGlas® ionoplast interlayer remains intact even if broken, providing a weather barrier that reduces the likelihood of total collapse of the building or widespread water damage. The plastic adhesive interlayer absorbs the energy of the impact resisting penetration. It prevents injuries related to flying glass or exposed shards. When a hurricane advisory warning is issued, there is no need to board up window openings or to activate / mount shutters.

Basic advantages of using an ionoplast interlayer such as SentryGlas® in lieu of PVB based interlayers include higher design loading capacity, larger glass lite sizes, higher resistance to penetrations, greater intrusion resistance, dry-glazing capability and better edge stability / durability.

More information to the use of Trosifol® PVB and SentryGlas® ionoplast in Hurricane glazing application can be found in the product brochure and the SentryGlas® technical manual on the website www.trosifol.com.



Photo: © NicoElNino/shutterstock.com

Chapter 6

Acoustic Interlayer

6.1. Acoustic basics

Ambient noise consists of a multitude of sounds of different frequencies and intensities coming from different sources. The measurement of noise intensity takes account of what is perceived by the human ear, which varies from person to person especially at different age.

Sound in physics term is a mechanical wave that propagates through a transmission medium such as gas, liquid or solid. In human psychology sound is the reception of sound waves and their perception by the brain.

Since sound is a wave, we can relate the properties of sound to that of a wave. The basic properties of sound are:

CHARACTERISTICS OF A SOUND WAVE

- Amplitude (Pa), (The size of the wave) = "Loudness"
- Frequency F (Hz), (Number of cycles per second) = "Pitch"
- Wavelength λ (m), (Wavelength and frequency are inversely proportional; double the wavelength and the Frequency is halved) = "Regularity"
Wavelength (λ) = speed (s)/frequency (f).

Noise is defined as any type of unwanted sound that is considered disturbing, annoying or painful.



Sound wave

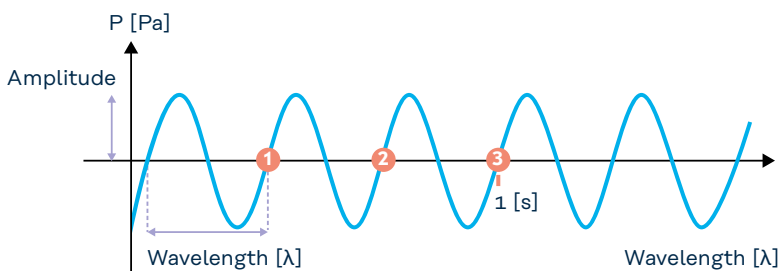

The example shows $3 \cdot f = 3 \text{ Hz}$

In addition to this also the sound pressure is a characteristic item. It is defined as the local pressure deviation from the ambient atmospheric pressure, caused by the sound wave. It is a force applied per unit area and is therefore given by the unit N/m^2 (Pa). On the other hand dB is a widely used unit of sound measurement and represents a logarithmic ratio of the power of the sound relative to the power at the threshold of the human hearing. The following graph shows typical sounds with their volumes and subjectively perceived intensities.

The range of human hearing covers the range of 0 dB to 120 dB sound pressure level. A difference of 3 dB is perceptible, a difference of 5 dB clearly noticeable. Doubling or halving of sound power equates to 10 dB increase in sound pressure level.

As a practical example one can estimate the external sound level of 65 dB, which is typical for road traffic as shown in the above graph. With an internal noise level of a living room with closed window of 35 dB the chosen glass construction needs in this example the sound reduction of $75 \text{ dB} - 35 \text{ dB} = 40 \text{ dB}$.

It is a proven fact that noise causes illness. People who are constantly exposed to unwanted, continuous noise nuisance suffer from such ailments as stress, nervousness, sleeplessness, poor concentration and cardiovascular disorders. To keep the effects of such problems within acceptable bounds, designers and architects are increasingly called upon to incorporate noise mitigation in building design. It is particularly important in this connection that the glazed surfaces of buildings in zones exposed to noise are correctly designed.

Noise sources and perception

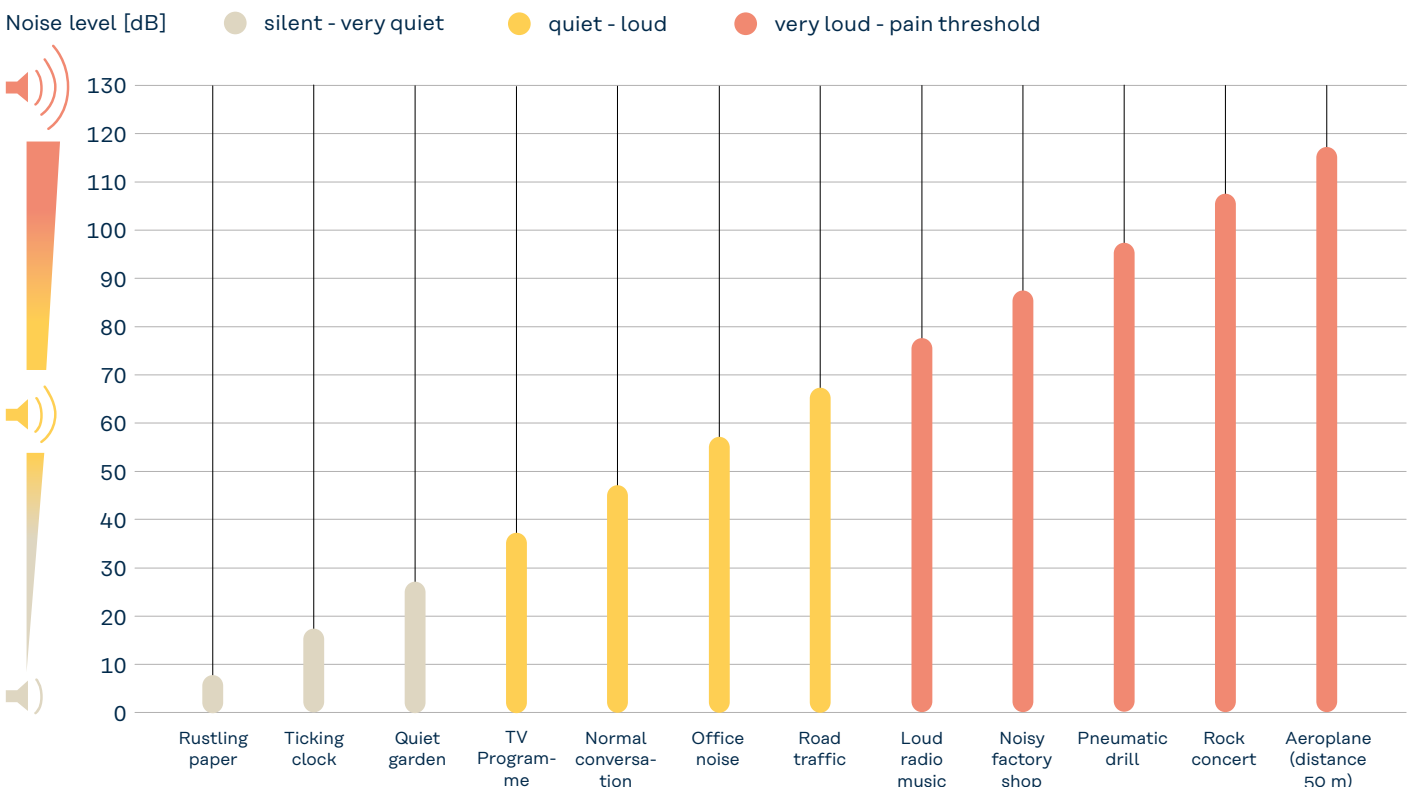

Air traffic

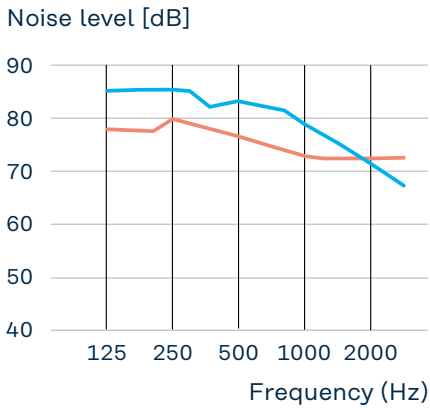

- Aeroplanes (taking off)
- Aeroplanes (landing)

Road traffic

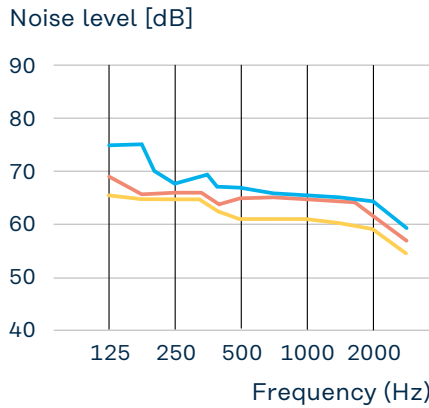

- Road junction
- Motorway
- Open and closed residential settlements

Rail traffic

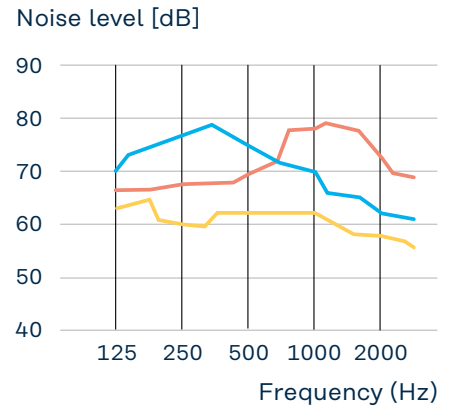

- Suburban trains
- High-speed trains
- Passenger trains/urban transport

In terms of noise source, a distinction is made between airborne sound (e.g. outdoor and indoor noise in buildings, interior inherent noise), footfall (interior noise) and structure-borne sound (equipment noise, water pipes, heating etc.). Effective sound protection means screening off the interior of buildings from noise generated outside.

The terms "sound reflection" and "sound absorption" must be clearly distinguished. In the first case, the sound energy is not converted into a different energy form, but its direction of propagation is changed by reflection.

To mitigate an existing noise nuisance perceived as noisy, two fundamental physical effects of wave propagation can be exploited:

- Noise mitigation by sound reflection
- Noise mitigation by sound absorption



6.2. Acoustic glazing for façades and windows

The most effective way of minimising the effects of noise entering a building from outside is by insulating the window. The glass surface itself as well as the glass frames and the window's installation position in the façade are crucial for effective sound insulation (reflection). For use in buildings, a large number of basic glass types and specially treated glass products are available.

The easiest way of a noise barrier in the facade or window glazing is the use of monolithic annealed glass as initial material out of a lot number of functional glass types. The sound insulation properties are – however – very weak: doubling the glass thickness improves sound insulation by about 5 dB. On the other hand, the glazing weight also doubles, and thermal insulation as well as safety and security properties are still poor.

By using a combination of two glass plies of the same thickness, only a slight improvement in the sound insulation values is usually achieved. This is because of the complex interactions between the two plies of glass and the cavity or air space between the two plies – similarly to the physical system of mass / spring / mass. To minimise this effect, the two glass plies must have at least a 30% difference in thickness. An improvement in the sound insulation performance is achieved by increasing the width of the cavity.

The cavity between the plies is usually filled with air; for better thermal insulation, noble gases such as argon or krypton are often employed. The latter gas is heavier than air and additionally enhances sound protection.

New demands relating to energy efficiency and climate protection in buildings have resulted in marked improvement in thermal insulation. In the window glazing sector, this has encouraged the further shift from existing double glazing to triple glazing for several times better thermal insulation. In double glazing, one or both plies of monolithic glass can be replaced with laminated safety glass to improve sound insulation, and in triple glazing one or both of the outer plies can be replaced with laminated safety glass containing Trosifol®. This achieves, firstly, significantly higher sound protection and, secondly, additional benefits in terms of safety/security, solar protection and design. Here again, sound protection can be considerably enhanced with a suitable choice of gas in the cavities between the three glass plies.



6.3. Laminated safety glass with Trosifol® Sound Control

6.3.1. LAMINATED ACOUSTIC SAFETY GLASS

With the development of Trosifol® Sound Control (SC) Monolayer and Multilayer PVB film, both special PVB acoustic grades, Trosifol® made a breakthrough in offering high performance acoustic glazing in the early 2000's years. Both interlayers being used in laminates and insulating glass constructions based on laminated glass combine the advantages of outstanding acoustic properties with all the safety and security features of a conventional laminated safety glass. The benefits of both products are summarized in the following figure.

Trosifol® SC Multilayer can be processed with the same parameters as Trosifol® Clear / UltraClear.

Owing to its similar composition, however the Trosifol® SC film has a flow behavior differing from that of standard PVB Film and must be processed slightly differently, the instructions as described below.

Compared to a monolithic glass of e.g. 8 mm thickness, an improvement of 5 dB can be achieved by using a laminated glass ply with Trosifol® Sound Control. By reducing the laminated glass thickness from 8 mm to 6 mm (= 25% weight reduction) the benefit in sound damping is still 3 dB compared to thicker monolithic glass.

Sound Control – select the right interlayers for acoustic and optical performance

Property	Trosifol® Clear / UltraClear	Trosifol® SC Multilayer	Trosifol® SC Monolayer
Acoustic performance	some	excellent	excellent
Optic	great good	risk for orange peel	great good
Films' combination	yes, standard and color	yes, standard and color	no
Ball drop performance*	P2A	P2A	P1A

TAB 37 * Between 2 x 4 mm + 0.76 mm (30 mil) interlayer

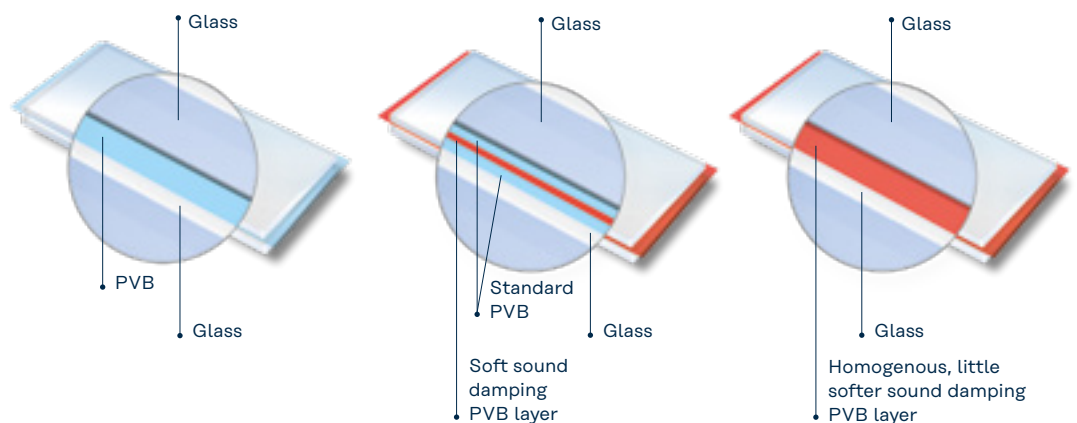

Owing to its softness, Trosifol® SC film has a flow behaviour differing from that of standard PVB films.

Cooling the rolls (to, for instance, 3 °C, if possible) has proven effective. Even reducing the temperature in the assembly room (e.g. to 13 °C) has a positive effect. The temperature of the washing water should also be reduced in order to cool the glass temperature.

- These two measures diminish the risk of film stretching with subsequent shrinkage.

It is possible to insert dual layers of Trosifol® SC film.

- With dual layers, it is essential to ensure complete de-airing as now there are not two but three layers of air between the glass plies and relatively soft PVB films.

We recommend a higher roll pressure than for our standard films. The nip should be at least 2 mm narrower than the sandwich thickness (narrower still for thicker sandwiches).

- The springy, soft PVB needs to be pressed well so that no residual air is trapped in the laminate.

The glass temperature after the first pair of rolls (assuming a 1st heating tunnel) should be $\leq 37^{\circ}\text{C}$ and never more than 40°C .

- Excessively high temperatures at the first pair of rolls may cause "over-rolled" residual air to be left in the assembly.

After the second pair of rolls, glass surface temperatures of 65°C or higher must be achieved.

- Excessively low temperatures at the second pair of rolls can prevent the PVB from bonding sufficiently with the glass and cause air to remain in the laminate.
- With thick plies, the glass surface temperature may be high, but the interior PVB/glass contact surfaces may not be sufficiently heated.

- Heat-reflecting coatings may prevent the glass core from being sufficiently heated and prevent contactless temperature measurement.
- Heat-reflecting glass with films removed from the edges may overheat at the edges and encourage premature edge sealing.
- Reducing the speed of the laminate in the second pair of rolls towards the tail edge of the glass can be useful.
- Watch out for differences in temperature on the left- and right-hand sides of the prelaminating line.
- Regularly check the contactless temperature sensors for correct indication.

In the autoclaving process, excessively short holding times (time at maximum pressure and temperature) and excessively low temperatures must be urgently prevented.

Acoustic performance of annealed vs. laminated glass

Monolithic glass



$R_w = 32 \text{ dB}$

STC 32

OITC 29

Laminated glass



$R_w = 35 \text{ dB}$

STC 35

OITC 31

Acoustic laminated glass



$R_w = 35 \text{ dB}$

STC 35

OITC 30



$R_w = 37 \text{ dB}$

STC 37

OITC 32

By reducing the glass thickness from 10 mm to 8 mm the sound damping benefit between monolithic glass and laminated glass with Standard PVB (Trosifol® Clear) and Acoustic PVB is again 2 dB or 5 dB in the latter case. The below graph shows a typical sound measurement curves as function of the frequencies and the measured data as column in direct comparison.

6.3.2. ACOUSTIC INSULATING GLASS

A similar effect of acoustic performance improvement can be observed in an insulating glass unit (IGU) with 2 or 3 plies, where monolithic glass on one or both sides can be replaced by a laminated glass unit. An example is shown in the next graph with double IGU and one unit of laminated glass, one with Standard PVB and the other with Acoustic PVB based laminate each with the PVB film thickness of 0.76 mm (30 mil).

Sound insulation with monolithic glass

Sound insulation [dB]

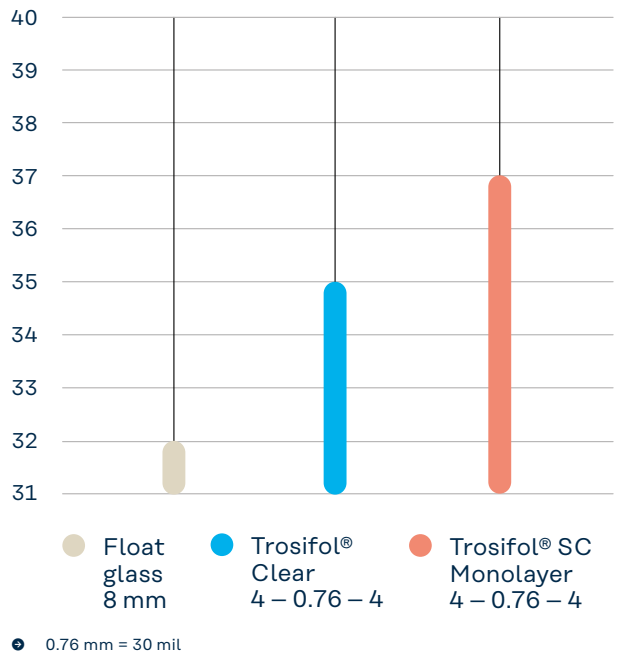

Comparison of the sound insulation of monolithic glass, LSG with standard PVB and LSG with Trosifol® Sound Control Multilayer

Sound insulation [dB]

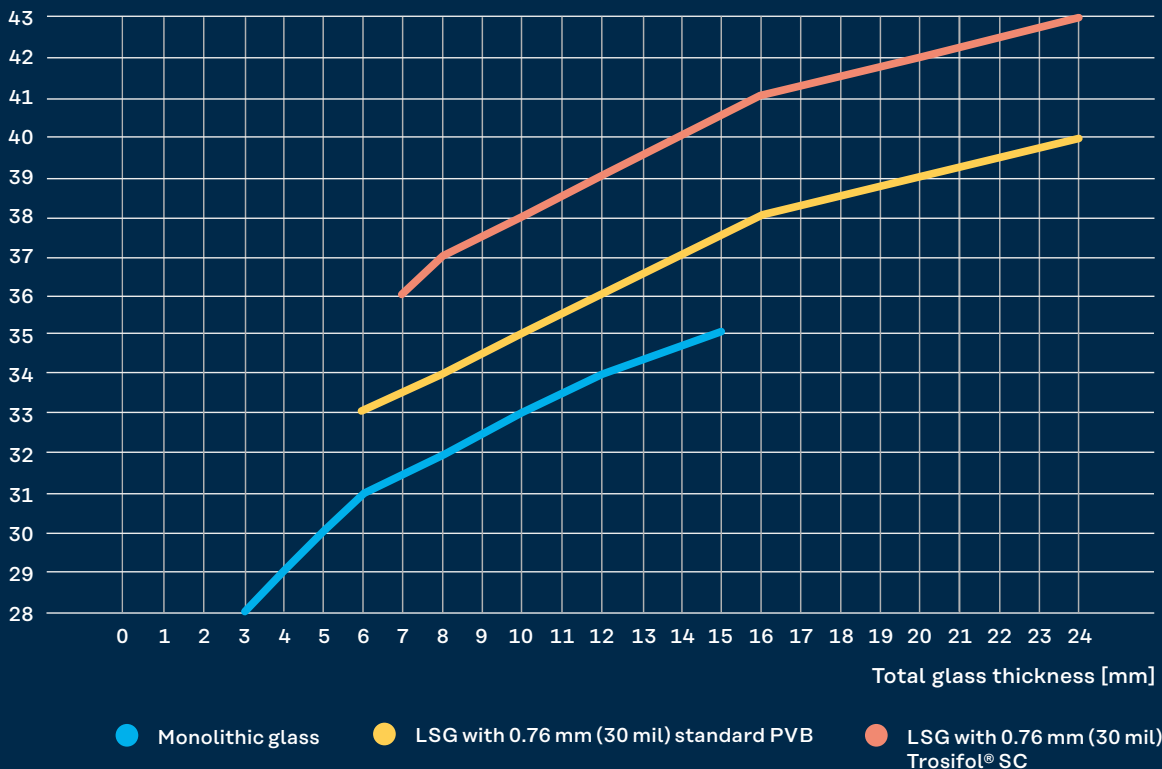

Acoustic performance IGU with different make-up

Laminated glass

Acoustic laminated glass



$R_w = 38 \text{ dB}$

STC 38

OITC 30



$R_w = 41 \text{ dB}$

STC 41

OITC 32

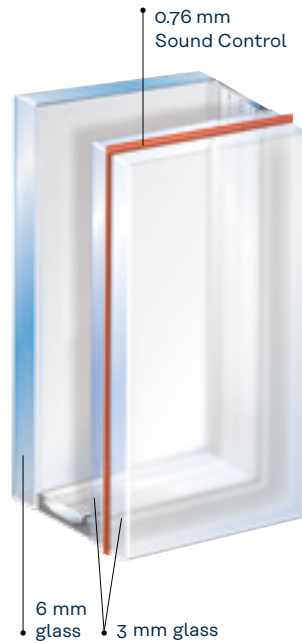

$R_w = 40 \text{ dB}$

STC 40

OITC 31

TAB 39 • 0.76 mm = 30 mil



An IGU fitted with a LSG and Acoustic PVB inside does not only improve the sound damping, but also can reduce the total window element thickness by keeping the high level of acoustic performance. This allows lower weight constructions – as already shown in chapter 6.3.1. - also in the window frame and other mounting systems thus saving costs. The following example shows the difference:

Sound insulation with multiple insulating glass

Sound insulation [dB]

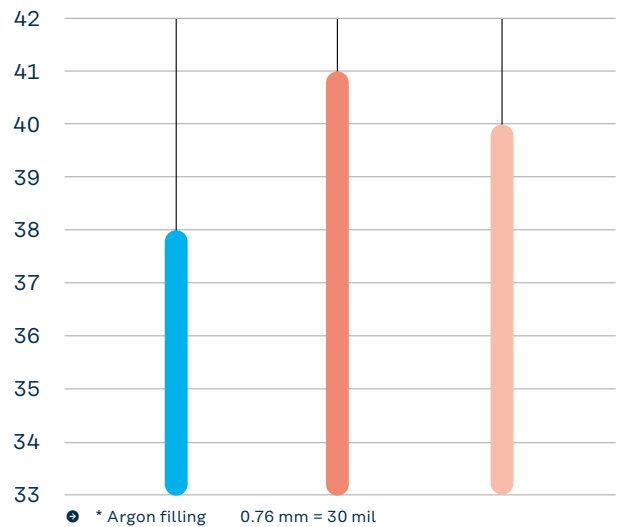

* Argon filling 0.76 mm = 30 mil

● 6 – 16* – 4 – 0.76 Trosifol® Clear – 4

● 6 – 16* – 4 – 0.76 Trosifol® SC Monolayer – 4

● 6 – 16* – 3 – 0.76 Trosifol® SC Monolayer – 3



THUMB RULES

- Doubling the laminate mass + 3dB
- Monolithic → standard PVB laminate: + 1 dB
- Monolithic → acoustic PVB laminate: + 4-5 dB
- Standard PVB Laminate → acoustic PVB laminate: + 3 dB
- Laminate → PVB thickness increase + 0 dB
- Laminate → Asymmetry/Symmetry + 0 dB

Trosifol® has measured a lot of laminated glass elements as well as double and triple IGU based on laminated safety glass acoustic PVB interlayers. The summary of the measured data is shown in the next graph, which gives the range of sound damping values with Trosifol® Sound Control film dependent on the laminate or IGU thickness.

1. LSG containing Trosifol® Sound Control film



2. Double glazing containing Trosifol® Sound Control film



3. Triple glazing containing Trosifol® Sound Control film

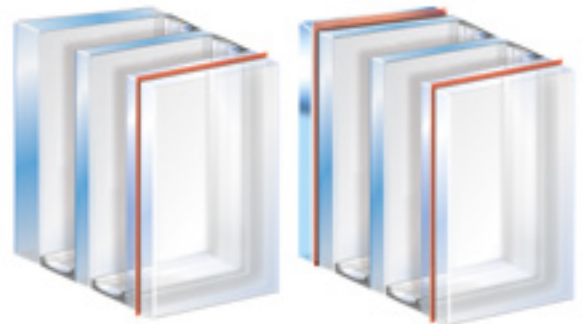

1. $R_w = 35-43$ dB

2. $R_w = 36-52$ dB

3. $R_w = 40-52$ dB

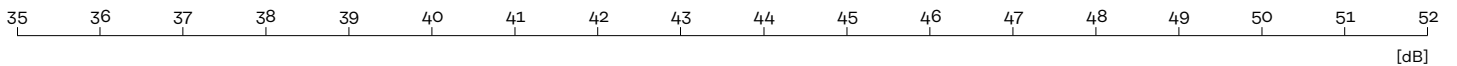

6.4. Measurement principle of glazing sound damping

The sound attenuation of different types of glass can be measured on a sound test installation in an accredited test laboratory. A glass unit, always of the same standardized size, is fitted with putty in an opening of the wall. At the front, a sound source projects sound of a given frequency – mostly between 50 to maximum 5000 Hz against the glass surface. Behind the glass is a microphone that measures the admitted sound volume in relation to the frequency.

A computer program then calculates a “mean sound attenuation value” from the measured values. The measurement is done always under defined climate conditions and temperature, which is given by the relevant acoustic glazing standard and has a big influence on the final result.

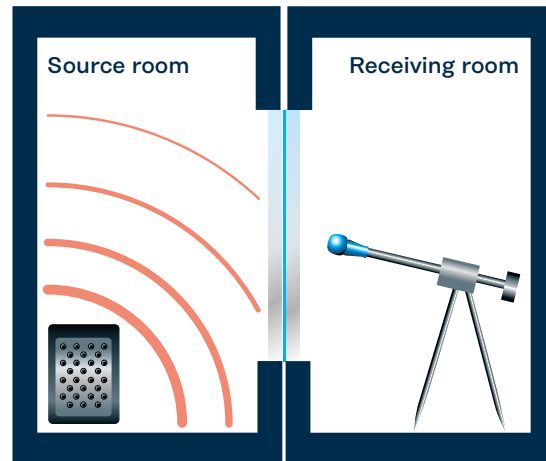

Acoustic performance levels are expressed using index R_w (C ; C_{tr}), expressed in decibels, as follows:

ACOUSTIC GLAZING TERMS AND DEFINITIONS

- R_w /STC is used to categorize glazing products and compare them to each other. Values are given in dB (decibel) according to standard EN 20140-3 (USA/ CND: STC ratings according to standard ASTM E 90, E 413)
- For noise containing predominantly high- and medium-range frequencies, sound insulating level is determined using the index R_w /+ C (e.g. noise from trains, schools, motorways, living areas etc.)
- For noise containing predominantly low- and medium range frequencies, sound insulating level is determined using the index R_w /STC + C_{tr} (e.g. noise from airports, traffic/trucks, disco music etc.)
- Low level noises is R_w + C_{tr} and for ASTM it is OITC per (ASTM E90, ASTM E1332).

6.5. Acoustical properties of Trosifol® Sound Control Monolayer and Multilayer

The following tables list all relevant sound reduction values R_w determined in external acoustic testing laboratories according to the standards EN 717 and EN 20140. The corresponding STC ratings were internally calculated according to the US standard ASTM 1332-10a on the base of originally measurement results.

0.76 mm (30 mil) Monolayer products – test results

Glass [mm]		Cavity air or argon [mm]	Glass [mm]		Cavity [mm]	Glass [mm]	R_w [dB]	C, C _{tr} [dB]	STC	OITC
3	SC Mono*	0.76	3				35	(-1/-4)	35	30
4	SC Mono	0.76	4				37	(-1/-3)	37	32
5	SC Mono	0.76	5				38	(0/-2)	38	34
6	SC Mono	0.76	6				39	(0/-2)	39	35
8	SC Mono	0.76	8				41	(-1/-3)	41	37
10	SC Mono	0.76	10				42	(0/-3)	42	38
12	SC Mono	0.76	12				43	(0/-3)	43	39
4	SC Mono	0.76	4	16	4		39	(-1/-5)	39	31
4	SC Mono	0.76	4	16	6		41	(-2/-6)	41	33
4	SC Mono	0.76	4	16	8		42	(-3/-8)	42	31
6	SC Mono	0.76	6	16	8		43	(-2/-6)	43	34
4	SC Mono	0.76	4	16	10		44	(-2/-6)	44	35
4	SC Mono	0.76	4	16	6	SC Mono 0.76 6	47	(-2/-6)	48	37
4	SC Mono	0.76	4	20	6	SC Mono 0.76 6	49	(-2/-7)	49	38
4	SC Mono	0.76	4	12	4	12	41	(-2/-6)	41	32
4	SC Mono	0.76	4	12	4	12	42	(-2/-6)	42	33
4	SC Mono	0.76	4	12	6	12	47	(-2/-7)	47	38

TAB 40 • *SC Mono = Trosifol® SC Monolayer

0.50 mm (20 mil) Multilayer products – test results

Glass [mm]		Cavity air or argon [mm]	Glass [mm]		Cavity [mm]	Glass [mm]	R_w [dB]	C, C_{tr} [dB]	STC	OITC
3	SC Multi**	0.50	3				36	(-1/-4)	35	30
4	SC Multi	0.50	4				37	(0/-2)	37	33
5	SC Multi	0.50	5				39	(-1/-3)	38	35
6	SC Multi	0.50	6				40	(-1/-3)	40	36
8	SC Multi	0.50	8				41	(0/-2)	41	38

TAB 41 • ** SC Multi = Trosifol® SC Multilayer



0.76 mm (30 mil) Multilayer products – test results

Glass [mm]			Cavity air or argon [mm]	Glass [mm]		Cavity [mm]	Glass [mm]	R _w [dB]	C, C _{tr} [dB]	STC	OITC		
3	SC Multi**	0.76	3					36	(-1/-4)	36	30*		
4	SC Multi	0.76	4					37	(0/-2)	37	33		
5	SC Multi	0.76	5					38	(-1/-3)	38	33*		
6	SC Multi	0.76	6					40	(-1/3)	39	36*		
8	SC Multi	0.76	8					41	(-1/-3)	41	37*		
10	SC Multi	0.76	10					42	(-1/-3)	42	38		
12	SC Multi	0.76	12					43	(-1/-3)	43	39		
3	SC Multi	0.76	3	16	4			36	(-2/-6)	36	28		
3	SC Multi	0.76	3	16	6			40	(-2/-6)	40	31		
3	SC Multi	0.76	3	16	8			42	(-3/-7)	42	32		
4	SC Multi	0.76	4	16	4			39	(-3/-7)	37	30*		
4	SC Multi	0.76	4	16	6			41	(-2/-6)	41	33*		
4	SC Multi	0.76	4	16	8			42	(-3/-8)	42	31*		
6	SC Multi	0.76	6	16	8			43	(-2/-6)	43	34		
4	SC Multi	0.76	4	16	10			44	(-2/-6)	44	36		
4	SC Multi	0.76	4	20	10			46	(-2/-6)	46	37		
6	SC Multi	0.76	6	16	10			44	(-1/-5)	44	36		
4	SC Multi	0.76	4	16	6 SC Multi	0.76	6	48	(-2/-7)	48	38*		
4	SC Multi	0.76	4	20	6 SC Multi	0.76	6	49	(-2/-7)	49	38*		
8	SC Multi	0.76	6	16	6 SC Multi	0.76	6	51	(-2/-6)	51	42		
8	SC Multi	0.76	8	16	6 SC Multi	0.76	6	51	(-1/-6)	51	42		
8	SC Multi	0.76	8	24	4 SC Multi	0.76	6	52	(-2/-6)	51	44*		
4	SC Multi	0.76	4	12	4	12	6	42	(-3/-8)	41	30		
4	SC Multi	0.76	4	14	4	14	6	43	(-2/-7)	44	33		
4	SC Multi	0.76	4	12	4	12	8	43	(-2/-7)	43	33		
4	SC Multi	0.76	4	16	4	16	8	45	(-3/-7)	45	34		
5	SC Multi	0.76	5	12	6	12	8	44	(-2/-7)	44	35		
6	SC Multi	0.76	6	12	6	12	8	45	(-1/-5)	46	37		
6	SC Multi	0.76	6	14	6	14	8	46	(-2/-6)	46	38		
4	SC Multi	0.76	4	12	4	12	4 SC Multi	0.76	4	46	(-2/-7)	47	35
4	SC Multi	0.76	4	12	6	12	4 SC Multi	0.76	6	47	(-2/-7)	47	37
6	SC Multi	0.76	6	12	6	12	4 SC Multi	0.76	4	49	(-1/-7)	50	39
6	SC Multi	0.76	6	14	6	14	4 SC Multi	0.76	4	50	(-2/-7)	51	40

TAB 42 • * Internally calculated according ASTM 1332-10a based on the originally measurement results ** SC Multi = Trosifol® SC Multilayer



6.6. Trosifol® SoundLab calculation program

Trosifol® and SentryGlas® has developed a specific software called SoundLab allowing the calculation of sound acoustic data on the base of the above listed originally measured data base. It is available on our website and can be downloaded from the apple Store and Googleplay. Target is to receive test certificates relative to the glazing composition choice of input and requirements of acoustical performance.

SOUNDLAB

For calculating acoustic performance of monolithic, double and triple glazed units.

<https://www.trosifol.com/trosifol-soundlab/>



SOUNDLAB AI

First global acoustic calculator based on artificial intelligence for calculating/estimating acoustic performance of monolithic, double and triple glazed units.

<https://www.trosifol.com/soundlab-ai>

kuraray
SoundLab AI

52.1 Trosifol® Clear / Trosifol® UltraClear - 2 mm Air - 43.2 Trosifol® SC Monolayer - 10 mm Air - 42.4 Trosifol® Extra BFR

#	Type	Thickness [mm]
1	Glass	5
2	Trosifol® Clear / Trosifol® UltraClear	0.38
3	Glass	2
4	Air	2
5	Glass	4
6	Trosifol® SC Monolayer	0.76
7	Glass	5
8	Air	10
9	Glass	4
10	Trosifol® Extra BFR	1.52
11	Glass	2

Layer structure

Area related mass = 52.85 kg/m²

Standard	Type	AI [dB]	Database [dB]
EN ISO 717-1	RW	39.7	No entry
ASTM E919-10	SFC	40.0	No entry
ASTM E932-10a	OITC	33.0	No entry

Standard **Type** **AI [dB]** **Database [dB]**

EN ISO 717-1 RW 39.7 No entry

ASTM E919-10 SFC 40.0 No entry

ASTM E932-10a OITC 33.0 No entry

Bestwertes Schallschirmmaß und Spektrum-Anpassungswerte nach DIN EN ISO 717-1

$R_w, C_2, C_1, C_2 + C_1, C_2 + C_1 + C_3$

39 | 10 | 5 | 6 | 5 | 68

Trosifol® SentryGlas® trosifol.com © M&H Network-Ing UG

Schallschirmmaß nach DIN EN 20 140-3:1995

Auftraggeber: HT TROPLAST AG
53840 TROSDORF

Prüfnummer: P-BA 2270003
886 1

Prüfgegenstand:

Isoliertescheibe (Prüfobjekt S 83291-01) mit folgendem Aufbau:
4 mm Floatglaslinde mit 2k Reflexionschicht
10 mm Scheibensand
9 mm Verbundstehverriegelungsscheibe (S.M.754/1mm, Typ: TROSIFOL SOUND CONTROL, Füllung des Zwischenraumes mit 89 % Argon-SC-Auslage vom 5. November 2003 wurde in einem Prüflaboratorium des IGB durchgeführt, das nach DIN EN 45 001 durch das DA-C-0095-06-00 akkreditiert ist.)
Abstandhalter aus Metallhöfprofil
Dichtung am Abstandhalter mit Butyl
Randverriegelung mit Polysulfid
Dicke der Scheibe in der Mitte: 29,5 mm
Dicke der Scheibe am Rand: 28,3 mm
Abmessung des Prüflings: 1230 mm x 1480 mm
Flächenbezogene Masse: 32,4 kg/m²

Prüffläche: 1,875 m²

Empfangsraum:
Volumen: $V_1 = 67 \text{ m}^3$
 $V_2 = 57 \text{ m}^3$

Art: Prüfstand
Zustand: leer
Flächenabmessung des Prüfstands:
 $R_{\text{max}} = 55 \text{ dB}$

Prüfbedingungen:
Lufttemperatur: 21 °C
rel. Feuchte: 54 %

Prüfmeth: 10a Rauchen

Prüfdatum: 8. Sept. 2000

Bestwertes Schallschirmmaß und Spektrum-Anpassungswerte nach DIN EN ISO 717-1

$R_w, C_2, C_1, C_2 + C_1, C_2 + C_1 + C_3$

39 | 10 | 5 | 6 | 5 | 68

Fraunhofer Institut Bauphysik

Die Prüfung wurde in einem Prüflaboratorium des IGB durchgeführt, das nach DIN EN ISO 17025 durch das DA-PL der W. DA-PL/2136.17 akkreditiert ist.
(Ultingen, 11. November 2000)

Prüfbedeutender: *i.v. v. lueck*



Photo: © SOM

Chapter 7

Specialized Interlayers

7.1. Trosifol® Spallshield® CPET

7.1.1. PRODUCT DESCRIPTION

Trosifol® Spallshield® CPET is a two layer composite structure of PET/hard-coat. The hardcoat is highly durable, chemically resistant, and virtually indistinguishable from glass. Trosifol® Spallshield® CPET provides superior lightweight anti-spall properties to glazing structures.

The PET and hardcoat help provide an inner shield to protect occupants from glass spalling and lacerations. Spalling is the term used to describe the action of glass splintering and flying inward after the glazing is struck by an object or bullet from the outside. Trosifol® Spallshield® CPET helps create a protective barrier between people and glass.

Because Trosifol® Spallshield® CPET laminates are glass/plastic all of the best features of glass are combined with those of plastic. The result is a glazing which is very lightweight, thin, and strong.

KEY BENEFITS

- **No spalling**
Anti-spalling feature of Trosifol® Spallshield® CPET composites helps provide safety to occupants of buildings, trains or autos when an object impacts the glass side of the glazing.
- **Weight reduction**
Trosifol® Spallshield® CPET laminates only require one lite of glass, making them lightweight.
- **Stronger**
Significantly higher penetration resistance with thinner glass vs. any other comparable laminated or monolithic glass constructions.
- **All the benefits of standard laminated glass**
UV protection, noise reduction, IR control when combined with special films or coated glass.
- **Excellent optics**
Glass + Trosifol® Spallshield® CPET composites meet all the automotive optics requirements.
- **Glass-like durability**
Highly abrasion, chemical and scratch resistant. Outstanding weathering.

Typical glazing construction using Trosifol® Spallshield® CPET

CPET is on the inside as the protective layer from spall.

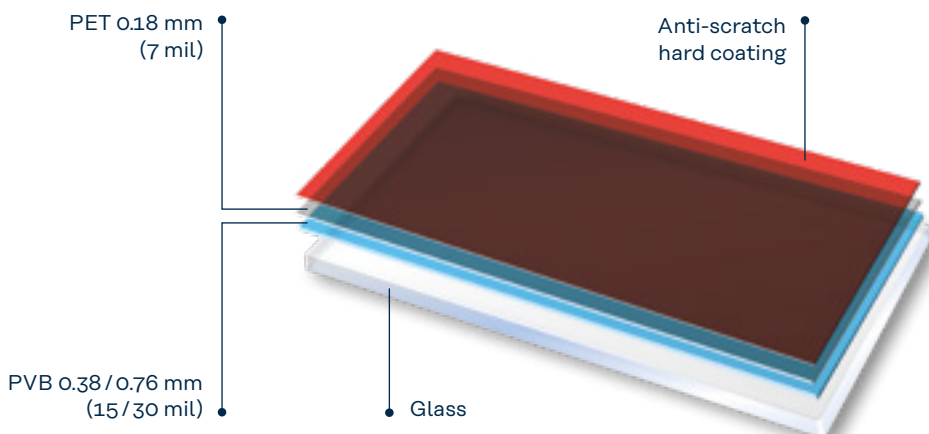

7.1.2. APPLICATIONS

Trosifol® Spallshield® CPET is used in applications where light-weight, penetration resistance and anti-spalling are desired attributes. Originally in use for many years in automotive glazing application (see Product Flyer and Technical Manual Automotive), Trosifol® Spallshield® CPET has also a widespread range of application in the architectural glazing sector like:

ARCHITECTURAL GLAZING

The anti-spalling and features of Trosifol® Spallshield® CPET composites make it an excellent choice in laminated glass glazing systems for embassies and other high risk public buildings. Trosifol® Spallshield® CPET helps protect occupants of a building from glass splinters even after a bullet or missile has been stopped, helping to keep people in the protected space from injury.

BULLET RESISTANT GLAZING

Traditional bullet resistant glazing performs as it is designed to perform which is to stop full penetration of a bullet; however, it does not prevent the spalling of glass, which can severely lacerate. Using Trosifol® Spallshield® CPET composite in bullet resistant glazings prevents this dangerous spalling of glass.

INTRUSION RESISTANT GLAZING

Glazing which is made from Trosifol® Spallshield® CPET are highly resistant to penetration and intrusion. This makes Trosifol® Spallshield® CPET ideal for use in high crime areas and storefront glazing by preventing the “smash and grab” crime.

TORNADO RESISTANT GLAZING

Trosifol® Spallshield® CPET enables laminated glass systems to meet the no spall requirements of FEMA 361 for EF tornado protection.

SKYLIGHTS

Trosifol® Spallshield® CPET provides protection of building occupants from spall which may occur from impact of falling object on the laminated safety glazing of the skylight.



7.1.3. PHYSICAL PROPERTIES

Technical data

Property	Test method	Unit	Trosifol® Spallshield CPET
Density	-	g/cc	1.4
Tm	DSC	°C (°F)	251 (483)
Self Ignition Temp	ASTM 1929	°C (°F)	460 (860)
Refractive index	-	-	1.44
Tear Propagation Machine Direction Transverse Direction	ASTM D2582	Tear Resistance (Newtons/Pounds-Force)	47.5 /10.6 40.3/9.08
Graves Tear Machine Direction Transverse Direction Machine Direction Transverse Direction	ASTM D1004-8 ASTM D1004-8 ASTM D1004-8 ASTM D1004-8	Max Force (Newtons/Pounds-Force) Max Force (Newtons/Pounds-Force) Extension (mm/in) Extension (mm/in)	90.8/20.4 94.2/21.1 9.24/.36 9.11/.36
Tensile Modulus Machine Direction Transverse Direction	ASTM D882-02	MPa (KPSI)	3884 (563) 5483 (795)
Tensile Strength Machine Direction Transverse Direction	ASTM D882-02	MPa (PSI)	156 (22) 205 (30)
Yield Stress Machine Direction Transverse Direction	ASTM D882-02	MPa (PSI)	103 (14.9) 123 (17.8)
Yeild Strain Machine Direction Transverse Direction	ASTM D882-02	%	6.97 6.66

TAB 43

OPTICAL AND UV PROPERTIES

Optical properties of Trosifol® Spallshield® CPET are equivalent to glass, resulting in clear, non-yellowing, very low haze laminates that are flat and free of wavy distortions. Trosifol® Spallshield® CPET provides superior UV protection over standard glass. Typical data is shown in tables: no iridescence can be seen. Iridescence is not seen under normal fluorescent lighting or outdoor lighting. This iridescence is not a defect but a phenomenon seen under specific lighting conditions.

ADHESION OF PET / PVB AFTER AUTO-CLAVE

When properly laminated, *Trosifol® Spallshield® CPET* has excellent adhesion to *Trosifol® PVB* interlayers. The laminates have excellent PVB to PET adhesion and PVB to glass adhesion is equal to or greater than traditional laminated glass structures. This ensures long term integrity of the final glass/plastic composite structure.

Optical properties and UV transmission data

Product	With PVB		Tvis [%]	YID 1925 (2/c)	UV transmission ISO 9050 282.5-377.5 nm
	[mm]	[mil]			
3 mm Float glass	-	-	92.2	- 0.59	64.37
Trosifol® Spallshield® CPET	0.76	30	91.3	1.35	0.48

TAB 44 •

CHEMICAL AND SOLVENT RESISTANCE, SCRATCH RESISTANCE

Trosifol® Spallshield® CPET laminates have superior chemical and solvent resistance to polycarbonate and acrylics. All samples were abraded with the Taber Abrader (ANSI Z26.1-1996 Test 17) and stressed to simulate actual end-use conditions. The abraded area was then exposed to solvents, wiped clean and graded.

Trosifol® Spallshield® CPET – chemical resistance

Chemical	Polycarbonate	Acrylic	Trosifol® Spallshield® CPET laminate
Methanol	No effect	Small cracks	No effect
Toluene	Deep cracks	Destroyed	No effect
Acetone	Destroyed	Many cracks	No effect
MEK	Cracks/tacky	Many cracks	No effect
Methylene chloride	Tacky	Cracks/tacky	No effect
Gasoline	Destroyed	Many cracks	No effect

TAB 45 •



• Glass room in former US Embassy

7.1.4. TROSIFOL® SPALLSHIELD® CPET TESTS

Trosifol® Spallshield® CPET is a two-layer composite structure of PET and hard coat. The hard coat is a proprietary formulation developed by Kuraray with the following features:

HIGHLIGHTS OF TROSIFOL® SPALLSHIELD® CPET

- Highly scratch resistant
- Chemically resistant
- Very durable
- Superior optical quality, indistinguishable from glass

Trosifol® Spallshield® CPET have superior abrasion resistance compared to acrylics and polycarbonates.

Taber Abrasion Resistance

Plastic sheet type	TBR (delta haze) without coating [%]	TBR (delta haze) with coating [%]
Polycarbonate	27.5	1.8
Acrylic	23,9	1.4
Trosifol® Spallshield® CPET	30.2	0.7
Glass	0.1	not applicable

TAB 46 •

IRIDESCENCE

Iridescence is caused by light being refracted off of thin coatings. The hard coat applied to Trosifol® Spallshield® CPET is a very thin coating with micro variations in coating thickness. This will cause the hard coat to iridesce under certain types of indoor fluorescent lighting and is only visible under reflective lighting. If the composite is viewed at a 90-degree angle no iridescence can be seen. Iridescence is not seen under normal fluorescent lighting or outdoor lighting. This iridescence is not a defect but a phenomenon seen under specific lighting conditions.

BOIL TEST

Conducting 6-hour boil testing per ANSI Z26.1 test method tests durability of hard coat. Tests are conducted on laminates autoclaved at 135 °C (275 °F) for 30 minutes. The hard coat is evaluated for adhesion and appearance.

Trosifol® Spallshield® CPET composites have 100% hard coat adhesion after the six hour boil. Hard coat appearance remains excellent.

COFFIN TESTS

Trosifol® Spallshield® CPET laminates are exposed to 50 °C (122 °F) at 95% RH for a period of 2 weeks. After the test, the hard coat adhesion remained at 100%. Optical appearance remained unchanged.

CYCLING TESTS

Cycling tests are conducted to predict the effects of exposing the Trosifol® Spallshield® CPET composite to extreme temperatures and humidity. Trosifol® Spallshield® CPET composites were tested by the PV1200 protocol. Trosifol® Spallshield® CPET composite is placed in a chamber and exposed to the following cycle 10 times:

TROSIFOL® SPALLSHIELD® CPET CYCLING TESTS

- 60 minutes heat up to 80 °C from 23 °C (up to 176 ° F from 73°F)
- 240 minutes at 80 °C (176 °F) and 80% RH
- 120 minutes to cool down to –40 °C (-40 °F)
- 240 minutes at –40 °C (-40 °F)
- 60 minutes to 23 °C (73°F)

Peel tests were measured after equilibrium of 21 hours at 20.5 °C (69 °F). Used Permalel 1.13 kg (40 oz.) tape for peels.

Trosifol® Spallshield® CPET coffin tests

Hard coat	Adhesion [%]
Unscribed	100
6 Line Scribed	100
X-Scribed	100

TAB 47 •



Photo: © vchal/shutterstock.com

Hardcoat adhesion performance (ASTM 3359)

Autoclave temps [°C]	Autoclave temps [°F]	Crosshatch – Scribed	Unscribed	X Scribed	Adhesion rating
125	257	100/5B	100	5/5	100
135	275	100/5B	100	5/5	100
150	302	100/5B	100	5/5	100

TAB 48 •

7.1.5. WEATHERING AND TECHNICAL DATA

Trosifol® Spallshield® CPET composites have excellent weathering durability. Sidelites made from Spallshield® composites were installed in a test vehicle 20 years ago and they still look outstanding!

Trosifol® Spallshield® CPET composites have undergone extensive weathering testing. The following weathering tests have been conducted on Spallshield® composites:

TROSIFOL® SPALLSHIELD® CPET WEATHERING TESTS

- EMMA
- Natural Florida
- XENON-ARC SAE-J1960

EMMA

	b color	Tvis [%]	Haze [%]	ISO 9050 UV transmission [%]
0 mega-joules of UV radiation per m ²	1.42	91.7	0.97	0.46
2000 mega-joules of UV radiation per m ²	1.62	91.4	0.78	0.68

TAB 49

2,000 mega-joules is equivalent to nine years Arizona. Laminates autoclaved at 135 °C (275 °F) for 30 minutes.

Natural Florida

	YID	b color	Haze [%]	Tvis [%]
Initial	2.8	2.35	0.62	91.7
2 years exposure	1.76	1.67	0.63	91.7

TAB 50

Samples were exposed two years in Florida.

XENON-ARC SAE J1960

	Laminate haze [%]	Laminate Tvis [%]	Laminate b color	PET/PVB adhesion [lb/in]
Initial	1.91	91.7	1.12	24.8
2,500 MJ	2.1	91.6	1.42	22

TAB 51

All samples were coated in the lab. Commercially produced Trosifol® Spallshield® CPET. Composite has haze value of < 1.

Trosifol® Spallshield® CPET with 0.76 mm (30 mil) PVB laminated to 2 mm glass

ANSI Z26.1 tests

Test	Name	Description	Measures	Requirement	Trosifol® Spallshield® CPET results
16	Luminous transmittance and weathering	Tvis is measured after exposing samples to type D twin enclosed (violet arc) chamber under standard operation for 1667 hours.	Tvis Change %	Less than 5%	-4.91%
1	Light stability and luminous transmittance	Samples exposed to a UV Arc test radiation for 100 hours	Tvis retention %	70%	99.70%
26	Ball drop	5 lb ball drop from 3.7 m (12 ft) at room temperature	Penetration	No penetration	No penetration
12	Ball drop	1/2 lb ball dropped 9 m (30 ft) at room temperature	Penetration	No penetration	No penetration
9	Dart test	0.2 kg (7 oz) steel dart dropped from 9 m (30 ft) at room temperature	Penetration	No penetration	No penetration
19	Chemical resistance	Laminated specimens are exposed on the plastic sides both in non-stressed and stressed conditions to five different specified chemicals for 10 min each using separate specimens in each case. The laminate must show no signs of tackiness, crazing, or cracking.	Haze %	4%	< 4%
24	Flammability	Three laminated specimens measuring 1.3 x 15.2 cm (0.5 x 6 in) are inclined at a 45 degree angle and are subjected to a flame on the plastic side at the lower end. Once the flame is removed, the burn rate must not exceed 8.9 cm/min (3.5 in/min).	Burn rate in/min	Max. 8.9 cm/min (3.5 in/min)	< 8.9 cm/min (< 3.5 in/min)

TAB 52 •

7.1.6. PROCESS INSTRUCTIONS

7.1.6.1. INTRODUCTION

This guide describes processes associated with lamination of Kuraray CPET to B500JR grade Kuraray Trosifol® Clear PVB. Lamination of Kuraray CPET to interlayer films other than Butacite® B500JR will require additional compatibility testing be done at the customer facility to achieve optimum quality laminates and long-term performance. Kuraray CPET can be laminated to glass using techniques similar to those used in producing laminated safety glass, with CPET taking the place of one of the glass lites. Please review Butacite® Laminating Guide if you are not familiar with standard laminating practices.

7.1.6.2. KEY DIFFERENCES TO STANDARD GLASS LAMINATION

1. The layup is de-aired using vacuum technology, either vacuum bags or vacuum rings. If planning to use vacuum rings, contact your Kuraray representative for further assistance.
2. The de-aired laminate must remain under vacuum throughout the autoclave cycle.
3. A removable glass cover plate covering the polyester surface is necessary if high quality optics is required.

7.1.6.3. SPECIAL CONSIDERATIONS – GENERAL

1. Kuraray CPET must not be sharply bent or kinked, as this will break the thin, hard coating. It must be handled with care. When unwinding, suspend CPET roll and assure that roll will rotate easily. Do not pull film CPET film with excessive force to unwind.

2. Cleanliness in the manufacturing environment should be particularly good as polyester generates static electricity when unwound and tends to attract dust and dirt. A class 10,000 environment is desirable, but if airborne particles 3-5 microns and larger are eliminated, excellent results will be obtained. Soft, lint-free gloves should be worn when handling CPET to avoid fingerprints/smudge marks on the surfaces. Smudges on the hard-coated side can be easily wiped off, but any on the non-coated side cannot be wiped away without permanently abrading the soft PET film surface. See the following section on contamination control.

No refrigeration is necessary, and moisture control is not critical. Layup room humidity of about 30 to 40% will reduce static electricity charges which tend to attract airborne dust. Relative humidity over 70% should be avoided. When storing the roll, the material should be protected, either with the original packaging material or by enclosing in some sort of wrap. Returning the roll to the original bag is suggested.

3. To facilitate cover plate removal after laminating, wash the cover plate in water of 100 to 300 ppm total hardness hard water solution. A solution of anhydrous Magnesium Sulfate mixed 0.300 g per liter of water will produce a 300 ppm solution. A solution of Epsom Salt ($MgSO_4 \cdot 7H_2O$) mixed 0.614 g per liter of water also produces a 300 ppm solution.
4. De-airing must be done with a vacuum system when cover plates are used. Polyester reinforced silicone rubber bags, silicone rubber vacuum rings, or throw-away bags of polyester or nylon sealed with „sticky tape“ are most commonly used. If planning to use vacuum rings, contact your Kuraray representative for further assistance.
5. To develop the best properties, we recommend that autoclave maximum temperature be 135 to 150 degrees Centigrade (275 to 300 degrees Fahrenheit).

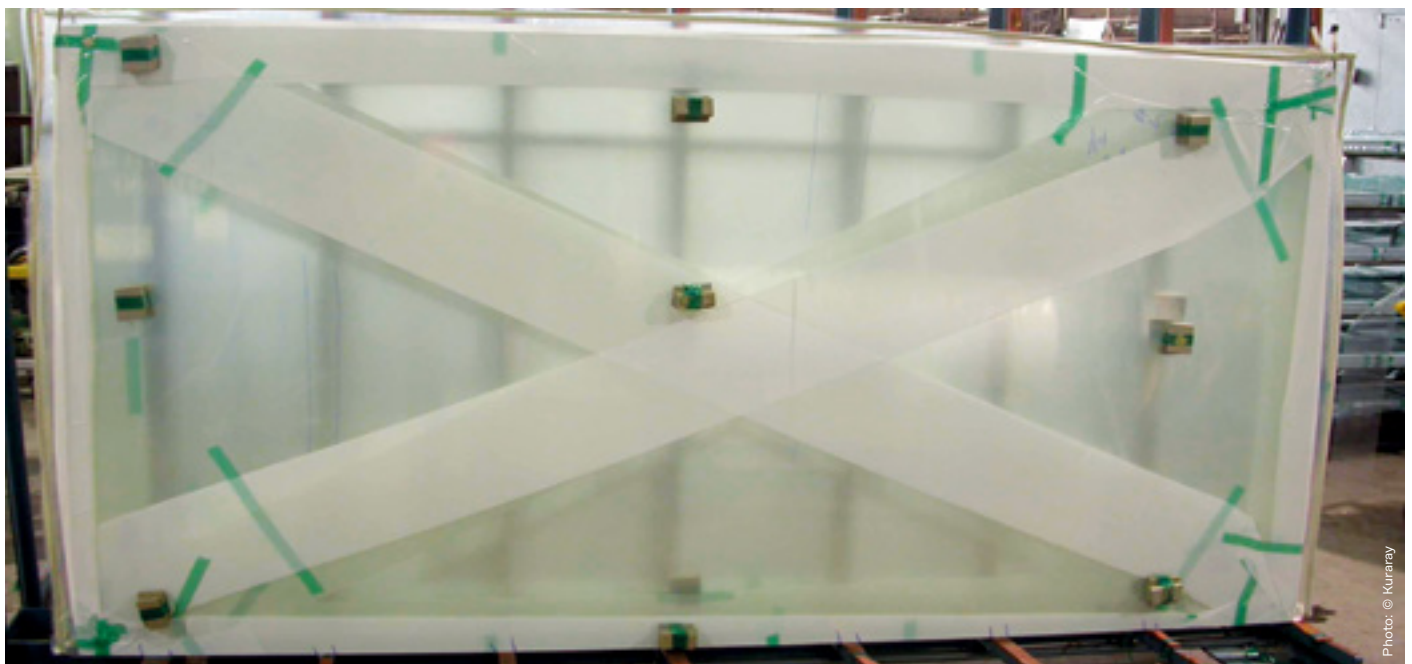

➤ Properly prepared CPET pre-press laminate

Avoid laminating CPET above 150C. Temperatures as low as 120 degrees C (250 degrees F) have been successfully used.

6. Kuraray CPET exhibits a “normal” iridescence pattern under certain types of lighting, both in raw film and finished laminate form. This pattern can show up very heavily under high efficiency fluorescent or mercury vapor lighting. When viewed in sunlight, yellow light, or soft white fluorescent lighting, the pattern is nearly invisible. The “normal” pattern is not a defect, but should be considered when finished laminate will be used indoors where high efficiency fluorescent or mercury vapor lighting is utilized.

7.1.6.4. SPECIAL CONSIDERATIONS LAY-UP AND LAMINATING

The lay-up step is the key to good results. The exact method varies, but some suggestions which generally improve results are listed below:

1. A good match between the curvature of the glazing and the cover plate is essential. If they do not „nest“ well, the cover plate will not contact the polyester surface completely, and the result will be areas of distortion on the surface of the plastic.
2. Assure that the hard-coated side of the CPET contacts the cover plate, with the uncoated side contacting the interlayer material. A 38 dyne poly test pen may be used to test the CPET. The pen will mark on the uncoated side, but will “bead up” on the hard-coated side. If a 38 dyne poly test pen is not available, many (but not all) commercial marking pens will also work the same way. One that is known to work is the Pilot® Fineliner.
3. The layup may be built up starting with the cover plate, then adding the CPET, then the interlayer sheeting, then the glass and then the rest of the construction (in the case of multi-layer laminate constructions). It is also possible to start with the glass lite, and then build the unit up from there, finishing with CPET and the cover plate.
4. Each surface must be inspected for cleanliness as it is placed. To better assure freedom from particulates at the interfaces, clean each surface before the next sheet/lite is positioned in the stack. The use of a cleaning device with antistatic capability, such as a TekNek cleaning machine, is recommended. Additional spot-cleaning as the laminate is laid up can be accomplished by wiping carefully with a lint-free wiping material, or by using a roller cleaner such as a handheld TekNek cleaning roller. Make sure that any surface that contacts either side of the CPET is clean! Never place CPET on the floor.
5. Be sure that there is a path for air removal using wicking material, and that the edges of the glazing are not sealed off by the bag, or pinched by the vacuum ring. It is recommended to have wicking material around the entire perimeter of the construction. In the case

of some larger constructions, additional wicking material and multiple vacuum ports may be required to obtain good results.

6. Cold Vacuum: 0.8 Bar (or deeper) vacuum is recommended. The evacuation time is dependent on the size and curvature of the glass. Minimum suggested cold de-airing time is typically 1 hour for large flat laminates and 20 minutes for smaller, curved laminates such as automotive side lights. Optimum time will be found through experience.
7. Autoclaving: Maintain vacuum continuously from cold vacuum throughout the entire autoclave cycle. Recommended autoclave cycle:
 - Temperature: 135 - 150 C hold temperature recommended if the interlayer is PVB;
 - 30 minutes at maximum temperature;
 - Pressure: 10 - 14 Bar;
 - Assure a good air circulation in the autoclave and avoid fold over of vacuum bags or other air flow restrictions along the laminates.

After autoclaving, be sure that laminate is cooled down well before releasing pressure. If the pressure is released too soon, the cover plate may prematurely release from the polyester surface. If this happens, a permanent distortion mark will be left on the surface.



7.2. UV Control PVB interlayer

Ultraviolet is electromagnetic radiation with a wavelength from 10 nm to 400 nm, shorter than that of visible light but longer than X-rays. UV radiation is present in sunlight, and constitutes about 10% of the total electromagnetic radiation output from the Sun. Ultraviolet (UV) light is invisible to the human eye. It is both vital yet potentially hazardous. Excessive exposure to this spectrum of natural light can damage the human skin and other materials.

UV-A RADIATION (315 NM TO 400 NM), which is called “near UV” and „black light“, is the least photo-biologically-active, but exposure can produce tanning and some burning of the skin, and can lead to the formation of cataracts. It is efficiently transmitted by air and common glass.

UV-B RADIATION (280 NM TO 315 NM), which is called “middle UV” and has shorter wavelengths and higher energy levels. It is partially absorbed by the ozone layer, but some rays still get through. About 5 percent of the UV rays that reach the ground are UV-B rays.

UV-C RADIATION (100 NM TO 280 NM), which is called “far UV” has the shortest wavelengths and highest energy levels of the three types of UV rays. As a result, it can cause serious damage to all life forms. Although not considered a risk for skin cancer, UV-C rays can cause severe damage to human eyes and skin, including burns, lesions, and ulcers on the skin. It is blocked by common glass and by air.

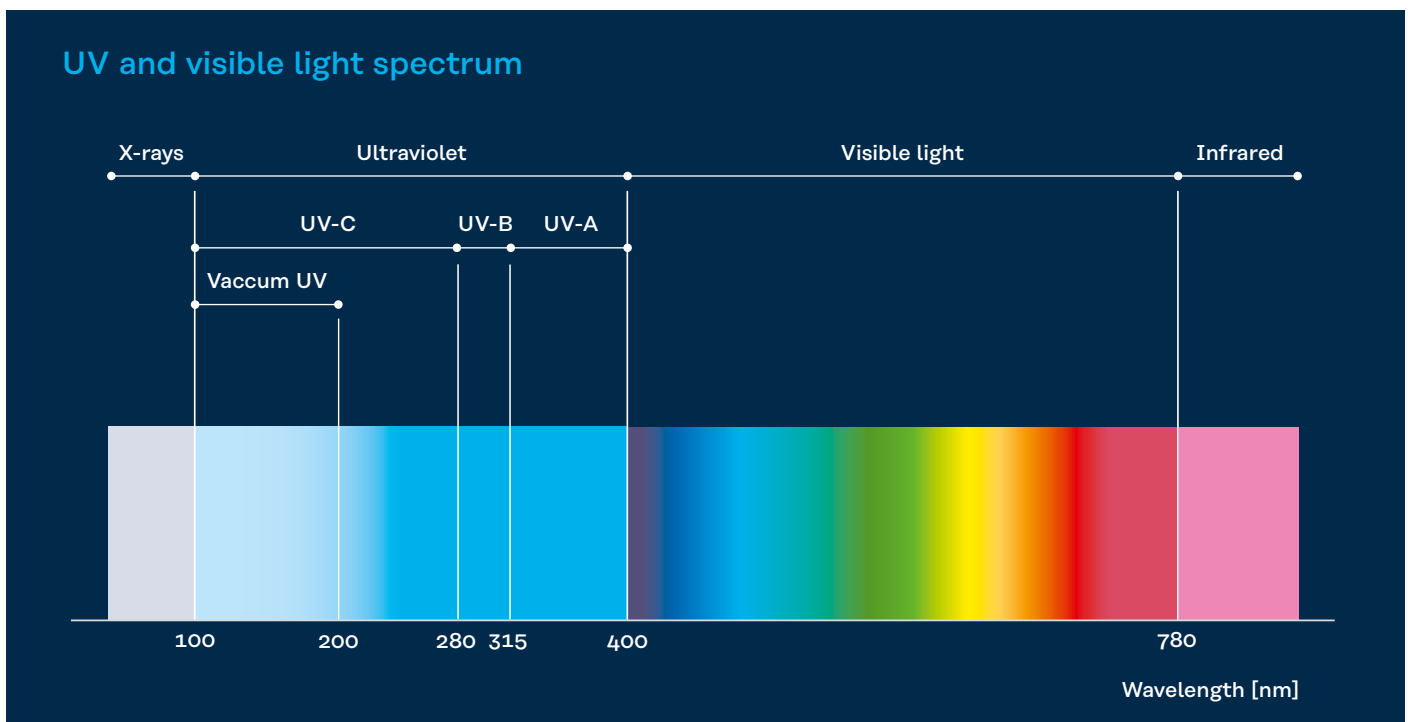

7.2.1. TROSIFOL® UV EXTRA PROTECT

Conventional Trosifol® PVB interlayer have about 99% UV filtering capability at 380 nm wavelength. Trosifol® UV Extra Protect, however, blocks 100% of the UV radiation at 400 nm in laminated glass. It therefore protects the human skin from damage, it protects e.g. carpets, curtains, furniture, wallpaper, photographs and things made of plastic against bleaching and/or embrittlement.

APPLICATIONS

- Museums
- Archives
- Galleries
- Hotels
- Restaurants
- Hospitals
- Shop windows
- Libraries
- Kindergarten
- Holiday resorts



• Botanical garden, Berlin, Germany

7.2.2. TROSIFOL® NATURAL UV

Trosifol® Natural UV PVB was developed to allow total UV-permeability for solar radiation through laminated glass with enhanced permeability for short-wave UV-A and UV-B radiation. It has on the other hand a remarkable resistance to environmental factors and enables long service life on exposure to heat and moisture in laminated safety glass. Applications include libraries, quarantine life science areas, zoos, aquariums, greenhouses, shopping malls with greenings and other areas where full-spectrum light is beneficial.

7.2.3. SPECTRAL DATA OF UV CONTROL PVB

Spectral data UV Control

Transmission	Trosifol® Natural UV / N-UV	Trosifol® Clear / UltraClear	Trosifol® UV Extra Protect
UV-Transmission / % EN410:2011	72.6	0.4	0.0
UV-Transmission / % @400 nm	89.3	77.2	0.5
Light Transmission / % EN410:2011	90.9	90.0	89.6

TAB 53 • * LSG with 2 x 4 mm Floatglass according EN 410/ISO 9050

Both interlayer products have identical lamination process compared to Standard Trosifol® PVB Series products, but should not be combined with them just not to lose their outstanding UV blocking or transmitting properties. For better safety and security properties they should only be combined with the same film type (double, triple layer etc.).

APPLICATIONS

- Greenhouses
- Botanical gardens
- Zoos

UV Transmission curve

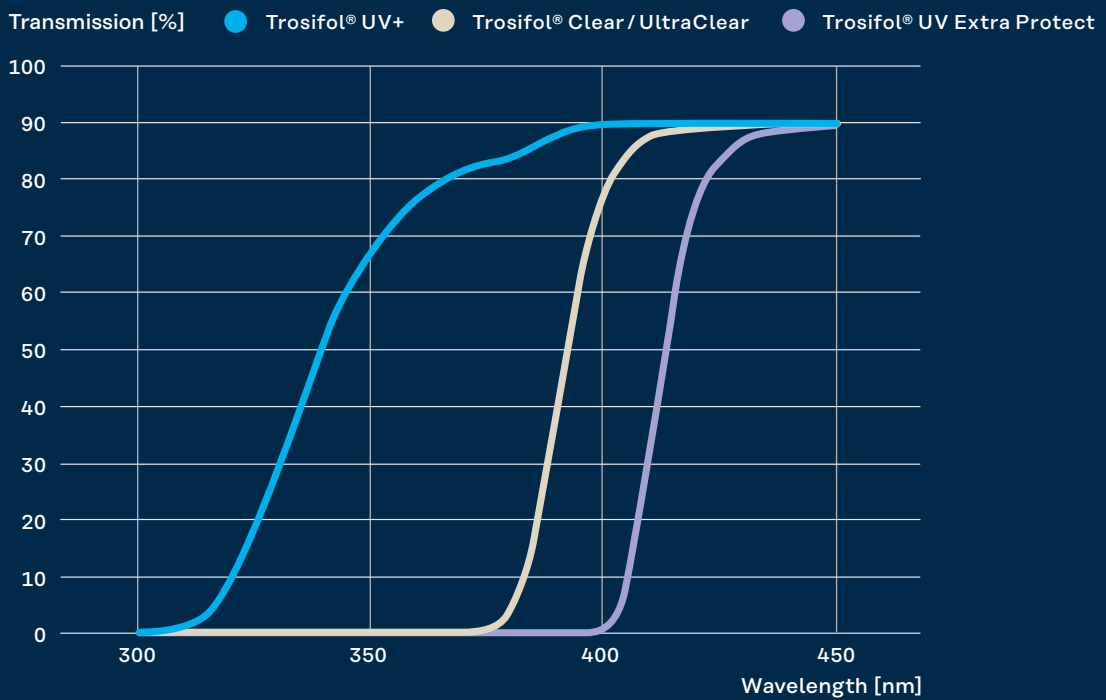

To calculate spectral data of Trosifol® UV Extra Protect, Trosifol® Natural UV and other interlayer out of the product portfolio the user can use the WIN SLT software from the website www.trosifol.com, also as an App on a mobile phone. It allows the calculation values for solar radiation and temperatures of glazing combined with sun and heat protection.

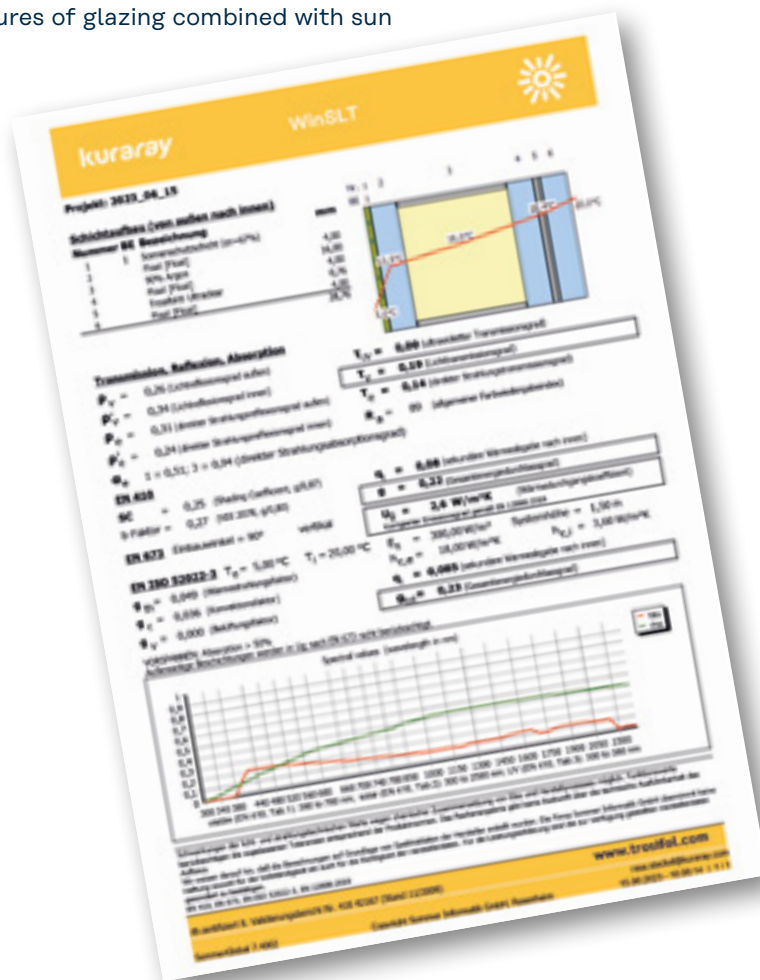



Chapter 8

Structural Interlayers

8.1. Introduction

The demands for high performance facades, where the infill glazing element plays an expanded functional roll, are continuing the drive for selection of laminated glass in modern architectural projects. Ionoplast (ionomer based) interlayers have been existing for several decades now. However, the most significant market introduction was in 1998 with the market launch of the SentryGlas® Plus (SGP) interlayer by the former DuPont Glass Laminating Solution (GLS). This product was designed especially for construction applications, with the focus on improving the structural properties and weather resistance of the laminated glass. Over more than two decades this interlayer has seen several improved developments, including the launch of SGP2000 in 2002 and of SGP5000 in 2006. From 2006, this product was renamed to SentryGlas®.

Under the leadership of Kuraray from 2014 the latest product modification SentryGlas® Xtra™ was launched in the year 2019.

Beside of ionoplast interlayer based on a non-PVB polymer and high-end solution a stiff interlayer on the base of PVB was developed by Kuraray named Trosifol® Extra Stiff. Being launched in 2013, this modified interlayer is stiffer than a Standard PVB like Trosifol® Clear or UltraClear, enabled by a lower plasticizer content which leads to a higher shear modulus, improved structural properties at higher temperatures and better edge stability compared to Standard PVB. More properties and laminating process conditions are described in detail in the following descriptions.



➤ Bell South Building, Fort Lauderdale, USA – One of the first buildings using laminated glass with SentryGlas®

8.2. Trosifol® Extra Stiff PVB

Trosifol® Extra Stiff allows maximum strength for minimum deflection at minimum laminate thickness up to 30°C/86°F, e.g. for indoor glazing applications like stairs, floors, walkways or railings and in moderate outdoor climate conditions.

Trosifol® Extra Stiff is available in the caliper 0.76 mm (30 mil) clear color up to a maximum roll width of 3210 mm. Delivery form details can be seen in chapter 2.5. It is handled and stored under the same condition as the Standard product Trosifol® Clear or UltraClear. The following table gives an overview of some physical data:

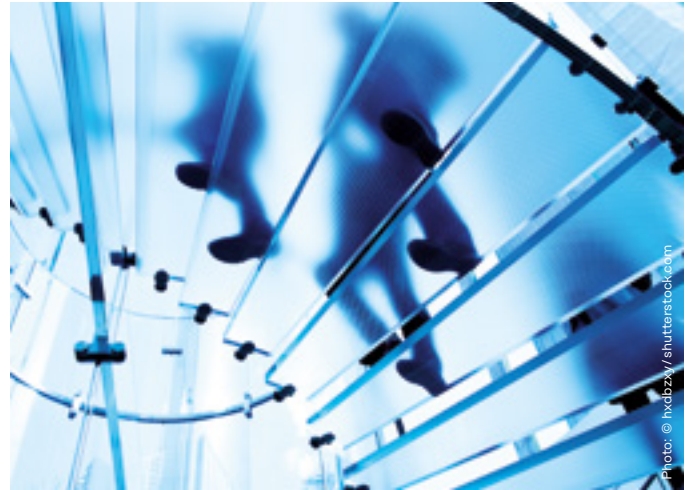

Technical data – Trosifol® Extra Stiff

Property	Test method	Unit	Trosifol® Extra Stiff
Density	DIN EN ISO 1183-1	g/cm ³	1.08
Refractive index	DIN EN ISO 489	-	1.486
Thermal conductivity	DIN EN 993-15	W/mK	0.22
Thermal expansion coefficient	ISO 11359-2	1/K	1.2E ⁻⁴
Specific heat capacity		J/g K	1.9
Surface resistivity	DIN 53482	Ω	> 10 ¹²
Tensile strength	ISO 527-3	N/mm ²	> 30
Elongation at break	ISO 527-3	%	> 180
Glass Transmission Temperature T _g	DMA, 3K/min, 1 Hz	°C	47

TAB 54 •



• People on Zhangjiajie Glass Bridge, China

The film process ability is equivalent to the conditions described for Standard PVB in chapter 3. Due to the higher stiffness at temperatures in the climatic conditioned lay-up room the manual cutting and edge trimming needs a bit more force and causes higher cutting knife consumption and change.

8.3. SentryGlas® Ionoplast interlayer

8.3.1. INTRODUCTION

Initially developed for the building envelope protection required for the hurricane glazing in USA and large missile impact in the late 90's, the use of SentryGlas® has now expanded considerably as structural engineers have recognized that the performance benefits for hurricane application could also be beneficial for many other components of a building, including facades, overhead glazing, balustrades, glass floors, staircases, doors and partitions.

Compared to PVB interlayers, SentryGlas® ionoplast interlayer is 5 times stronger and up to 100 times stiffer and performs better over a wide range of temperature. If PVB is loaded, it creeps away at very low stress levels, whereas SentryGlas® needs much higher forces to deform it. In addition, coupling effect are almost 100% with an ionoplast interlayer, enabling larger glass spans and a reduction of fixing points for frameless glazing. By changing interlayers, glass thicknesses can be down-gauged by around 30%, reducing embodied energy and supporting structures through lower weight. SentryGlas® also provides excellent weather resistance as well as exceptional edge stability under extreme climatic conditions.

Chemically an ionoplast in general terms consists – in difference to PVB – of a hydrocarbon backbone containing pendant acid groups which are partially or completely neutralized. In special case of SentryGlas® ionoplast the hydrocarbon

Chemical structure of ionoplast

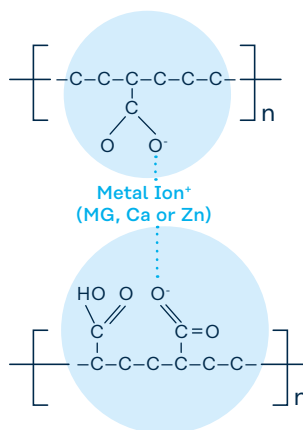

backbone is constituted by Ethylene and Methacrylic acid copolymer. The polymer does not contain any plasticizer different to the PVB interlayer, but behaves as a thermoplastic material but with a significant higher melting temperature (55°C/131°F). Therefore the ionoplast, which is stabilized by additives like a UV-filter, can be extruded - in a similar way to PVB – to a film thickness of 0.76 mm or 0.89 mm (30 or 35 mil); if thicker than 1 mm (from 40 mil upwards) it is extruded to sheets up to a caliper of 3.04 mm (180 mil).

To summarize the structural performance of stiff interlayers in comparison to Standard PVB, the following statements are valid:

Interlayer performance comparison

Properties	Trosifol® Clear / UltraClear			Trosifol® Extra Stiff			SentryGlas® ionoplast		
	Good	Advanced	Superior	Good	Advanced	Superior	Good	Advanced	Superior
Post breakage performance at room temperature	✓					✓			✓
Post breakage performance at elevated temperature	✓				✓				✓
Structural properties/ coupling effect at room temperature	✓					✓			✓
Structural properties/ coupling effect at elevated temperature	✓				✓				✓
Clarity		✓*	✓**		✓				✓
Sealant compatibility/ edge stability	✓*	✓**			✓				✓

TAB 55 • * Valid for Trosifol® Clear ** Valid for Trosifol® UltraClear



8.4. Processing of SentryGlas®



8.4.1. PACKAGING

Kuraray offers SentryGlas® interlayer both as sheets that are packed horizontally on a pallet (Figure 1) and in roll form (Figure 2). Both come hermetically sealed in foil bags to protect the sheets from moisture and contamination. The foil package is encased in cardboard to prevent damage that can occur during shipping.



FIG1 • SentryGlas® interlayer sheet package on pallet



FIG2 • SentryGlas® interlayer roll package on pallet

8.4.2. HANDLING AND STORAGE

Unopened sheeting and rolls require no temperature control for storage because SentryGlas® does not “block” like PVB interlayer does. SentryGlas® sheeting maintains its properties and overall quality consistency for many years under moisture proof storage conditions. Since moisture pick up over time can lead to deterioration in glass adhesion performance, it is recommended that SentryGlas® sheets or rolls in unopened packages be tested for moisture level and post lamination adhesion performance if the product is stored beyond three years from its original manufacturing date.

SentryGlas® will however, absorb water when opened packages and rolls are exposed to ambient conditions. *While the water absorption rate is very slow compared to PVB, water absorption of SentryGlas® will adversely affect adhesion.* It is recommended that the interlayer not be used if the moisture exceeds 0.2 % (when measured by Karl Fischer titration).

Figure 3 is the graph showing water absorption rate for 90-mil sheeting exposed to 3 different relative humidity levels. Upon opening, all packages or rolls of SentryGlas® need to be *properly resealed*.

90-mil SentryGlas® 5000 Water absorption Vs % RH

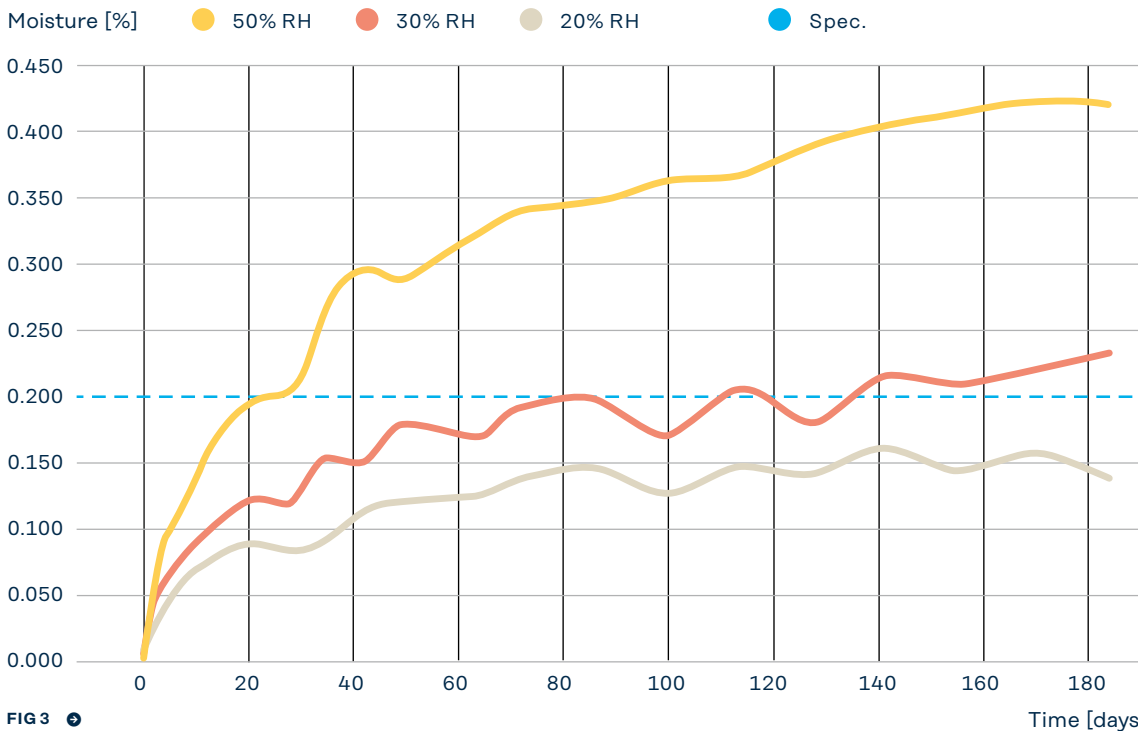

The recommended procedures for storing and handling of SentryGlas® differ for sheets versus rolls. SentryGlas® sheets are packaged horizontally in stacks that are wrapped in a moisture resistant foil packaging film and shipped on pallets. Cardboard is used to both support the package and minimize sheet deformation. The packages should be stored so that the sheets do not become deformed which could impact lamination. Heavy loads placed on SentryGlas® sheet stacks can deform the sheets through the packaging foil. The protective cardboard top layer should always be as the barrier between stacks. Product pallets can be stacked on one another, up to 5 pallets, provided that the stack top surfaces are supported with the cardboard flat to prevent pallet runner boards from imprinting product sheets through the foil packaging. The use of overhead racks (see Figure 4) is a good alternative to stacking pallets on the floor since it minimizes sheet deformation while reducing the overall storage footprint. The recommended procedure for opening the foil packaging, removing sheets and then resealing it is:

1. Use a utility knife or scissors to trim off the excess foil just inside the heat sealed line (see red arrow in figure 5) leaving as much excess foil as possible for resealing.
2. Using lint free gloves, remove the top sheet by lightly “wafting” it once prior to pulling it out of the bag. This process forces air underneath the sheet allowing for easy removal.
3. Close the bag and fold over the excess foil. Seal the entire seam to the bulk of the package using either a medium tack tape (see Figure 6) or a heat gun.

Resealed packages can be stored in either a humidity-controlled environment or under ambient conditions. If there is a concern regarding the moisture level of an opened package please contact your Kuraray sales or technical representative prior to use.

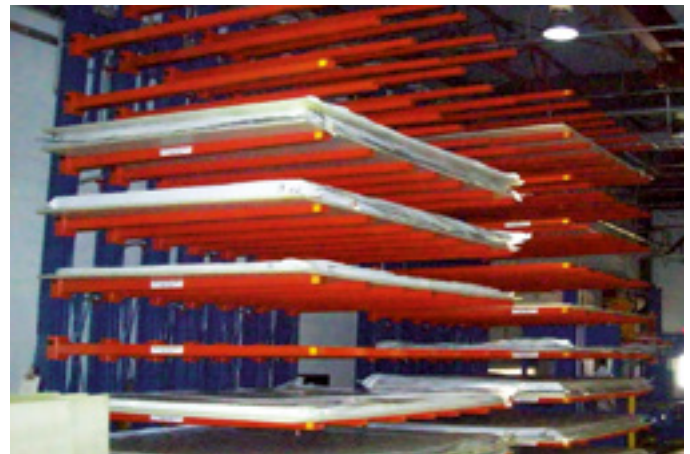

FIG 4 • Overhead storage racks



FIG 5 • Heat sealed line in foil packaging

RECOMMENDATIONS FOR STORAGE CONDITIONS OF SENTRYGLAS® ROLLS OR SHEETS:

- **Originally sealed:**
 - Roll or sheet can be stored in temperatures **not exceeding 30°C (86°F)**
- **Opened packaging:**
 - **If roll or sheet is directly used:**
In an air-conditioned room **at 18-20°C (64-68°F) and 25-30% RLH** (same conditions as PVB)
 - **If the material is stored for longer time:**
In an air-conditioned room **at 18-20°C (64-68°F) and ≤10% RLH**

RECOMMENDED PROCEDURE FOR STORING AND HANDLING THE ROLLS

1. Always store and handle a SentryGlas® interlayer roll horizontally not vertically.
2. The roll crates can be double stacked.
3. Open the crate and then using straps (see figure 7) lift the roll and place it onto a cradle (please note when using straps ensure the roll is properly balanced). Remove the endplates and core plugs.
4. Using either a horizontal roll lift (see figure 8) or another similar device suspend the roll off the cradle. Then carefully open the moisture proof packaging by either:
 - a. Trimming open one end of the foil and sliding the foil off over the roll or
 - b. Cutting the foil near the seal to retain as much original packaging material as possible and removing it.
5. Retain the moisture resistant bag for future use.
6. Place the SentryGlas® interlayer roll into the desired carousel
7. Cut the sheeting to the desired size using a Rosenthal or similar type sheeter and stack the sheets with the edge curl face down.
8. After sheeting is complete remove the roll from the carousel. Cover the SentryGlas® interlayer roll with the original moisture resistant packaging. Collapse the moisture resistant packaging around the roll to remove as much air as possible. Seal any opening in bag with tape.
9. Insert the excess foil from each end into the core and re-insert the end plates and core plugs.
10. Inspect the roll for holes or tears in the foil packaging.
11. Place sealed SentryGlas® interlayer roll in storage.



FIG 6 SentryGlas® interlayer package – properly resealed with tape

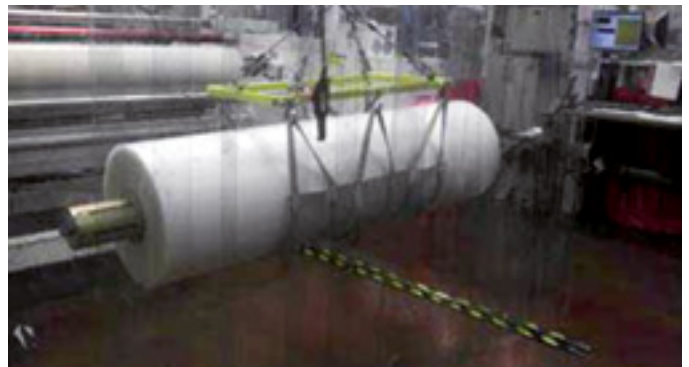

FIG 7 Horizontal roll sling

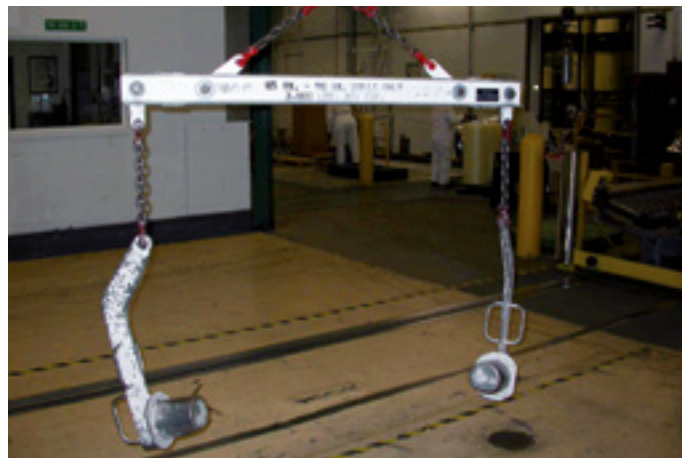

FIG 8 Horizontal roll lift

8.4.3. CUTTING AND TRIMMING

The SentryGlas® interlayer sheeting needs to be properly sized prior to lay-up if not purchased cut-to-size. The recommended methods for sizing involve using a shear cutter or an automated table cutter, since these minimize the cutting debris compared to other methods such as sawing. Since the sheeting has excellent dimensional stability, it can be cut to nominal glass dimensions and post-assembly trimming may not be required.

SIX TYPICAL METHODS USED TO CUT SENTRYGLAS®

1. Shear type guillotine
2. Static automated table cutters (e. g. Eastman)
3. Utility knife: Score → Fold over → Tear
4. Die cut
5. Machine score then snap out
6. Size with a Rosenthal or similar sheeter 0.76 mm / 35 mil sheeting only)



FIG 9 • Cutting SentryGlas®: Score pattern using a utility knife

For initial trials, the most straightforward and economical method to cut SentryGlas® is to use a utility knife. The recommended procedure for this method is detailed below.

1. Use a template to ensure the interlayer is cut to the proper dimensions. If laminating a curved or irregular shape surface (like a sidelite) an unbent sidelite or glass lite works very well. Trace the template with a utility knife or a razor cutter leaving a light score mark (Figure 9).
2. Fold the sheet along the entire scored perimeter.
3. Tear/snap-out along the scored boundary (figure 10).
4. Remove any debris using a Tek Nek roller or a lintless wipe.

The use of a saw is not a recommended method for sizing the interlayer unless the cuts can be made with little or no edge debris.

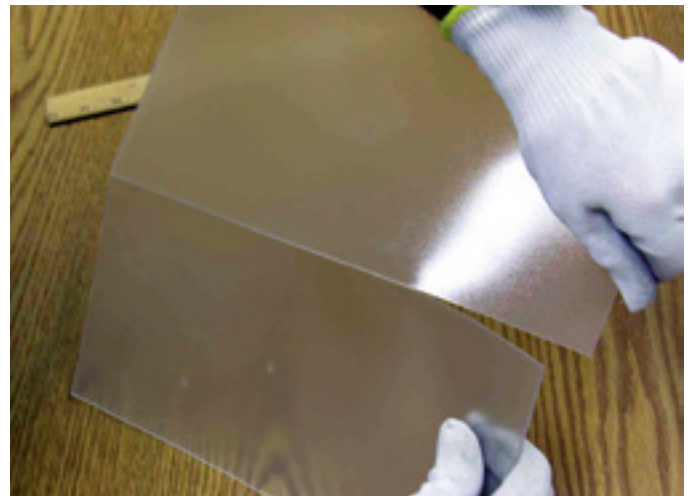
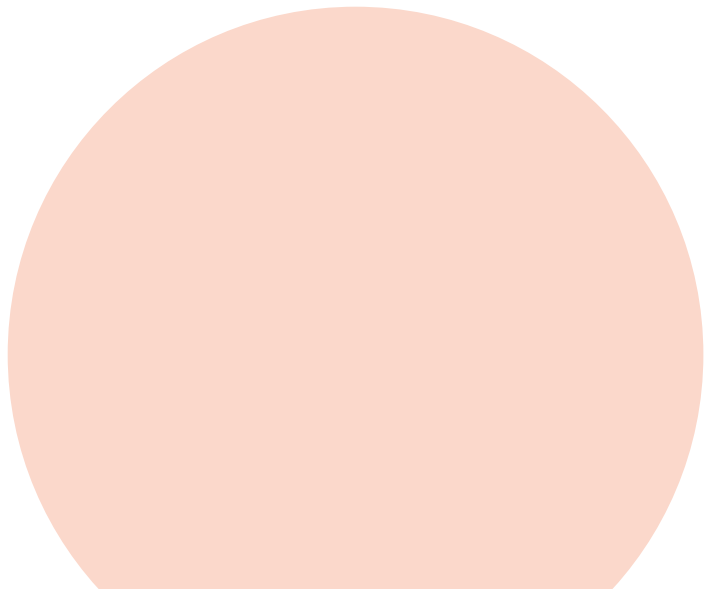

FIG 10 • Cutting SentryGlas®: Tear along scored pattern



8.4.4. CLEANING

SentryGlas® interlayer sheets are delivered clean but they are electrostatic. This can result in surface contamination if not cleaned during lay-up. Prior to assembly a final cleaning step is recommended especially if the sheets are cut or trimmed. Cleaning can be done by using one of the following methods:

- Contact tacky roller (e.g. Tek Nek or SDI (see Figure 11). Ensure that when purchasing the tacky rollers and cleaning pads that they are silicone free.
- Ionized air
- Lintless wipe

Use of a glass washer for cleaning SentryGlas® is not recommended. If the interlayer is cut using a saw (not recommended), it may be necessary to remove sheet shavings using a glass washer. If a glass washer is necessary, the following details are suggested:

- Do not use detergent.
- Use de-ionized (DI) water.
- Ensure water temperature is kept below 100°F (38°C). The use of hot water increases the potential for sheets to get caught in the glass washer.

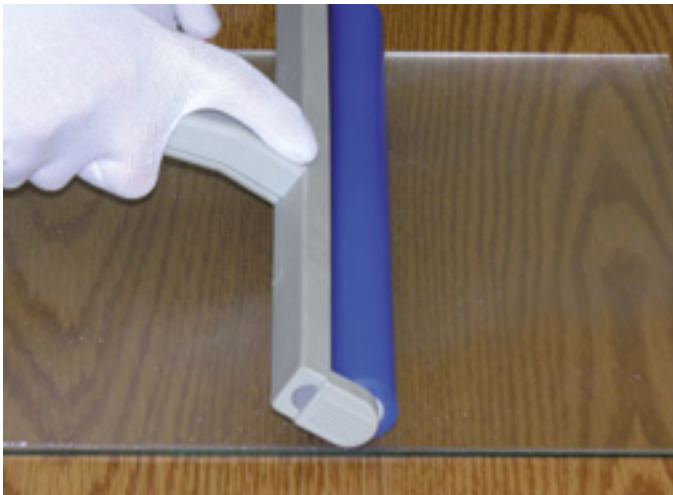

FIG 11 → Cleaning SentryGlas® with contact roller

8.4.5. GLASS WASHING

The recommended method for cleaning the glass is to wash with detergent and rinse the lites with de-mineralized or de-ionized water. The use of unfiltered (hard) water or simple ion exchange (soft) water to clean the glass is not recommended since it may lower the laminate's adhesion. Excellent results have been obtained using various commercial grade detergents such as Basic H; however, the effect of specific detergents on the adhesion of SentryGlas® has not been detailed. Each detergent should be evaluated prior to routine production. Good adhesion can also be obtained without the use of detergent but the temperature of the wash water should be > 54 °C /130°F to ensure the best results.

8.4.6. ASSEMBLY

Before assembly, ensure that the glass is dry. The SentryGlas® must utilize one of the following constructions:

1. Laminate SentryGlas® directly to the tin-side of the glass (an orientation of ATTA - glass *airside* / glass *tin-side* / SentryGlas® / glass *tin-side* / glass *airside*).
2. Use an adhesion promoter for all applications that result in SentryGlas® not being laminated against the tin-side of the glass (airside construction e.g., multi-laminates, glass not made using a float process, etc.)

8.4.7. ROLLER PROCESS

Glass lamination requires a de-airing step to remove the air at the glass/interlayer interface. De-airing can be accomplished with either a roller press (single or double nip) or using a vacuum process. The embossed surface of the SentryGlas® facilitates the de-airing process before adherence to the glass occurs. While SentryGlas® interlayer in sheet form will lay flat on the glass at assembly there may be some waviness in the rolled sheet at lay-up (see figure 12). While the undulations in the sheeting may increase when stacking multiple sheets (see figure 13) the waviness should not impact final laminate quality if processed per the recommended nip roll guidelines (see figure 14).



FIG 12 → Prepress interlayer waviness



FIG 13 • Prepress interlayer waviness multiple sheets

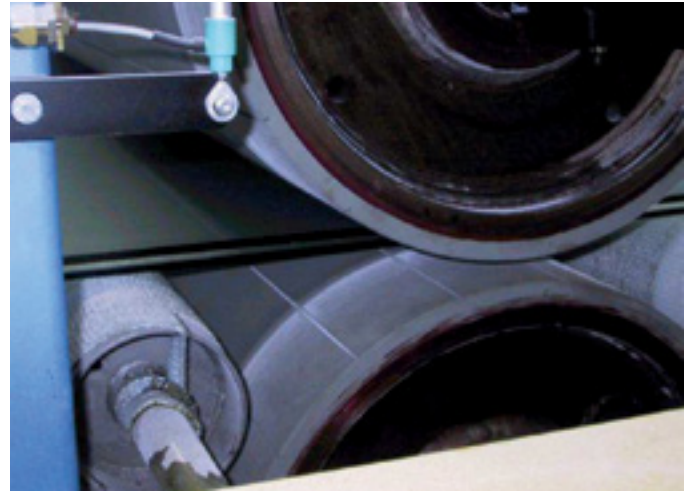

FIG 14 • Nip roll process

Due to variations in equipment, the optimum temperatures and nip roll settings can be different for each laminator. Line speeds will depend on the temperature of the laminates during the process and the laminate appearance upon exiting the furnace. The laminate temperature will depend on many factors such as glass thickness, glass coating, oven type, and oven settings. Line conditions, such as power output and wavelength, can vary greatly for an IR furnace compared to a convective furnace. Although wavelength dependent, SentryGlas® interlayer absorbs IR radiation much better than glass (see Figure 15) thus line speeds are faster than processing using a convective line. The following guidelines are recommended for the initial lamination of SentryGlas®.

SentryGlas® total solar transmission

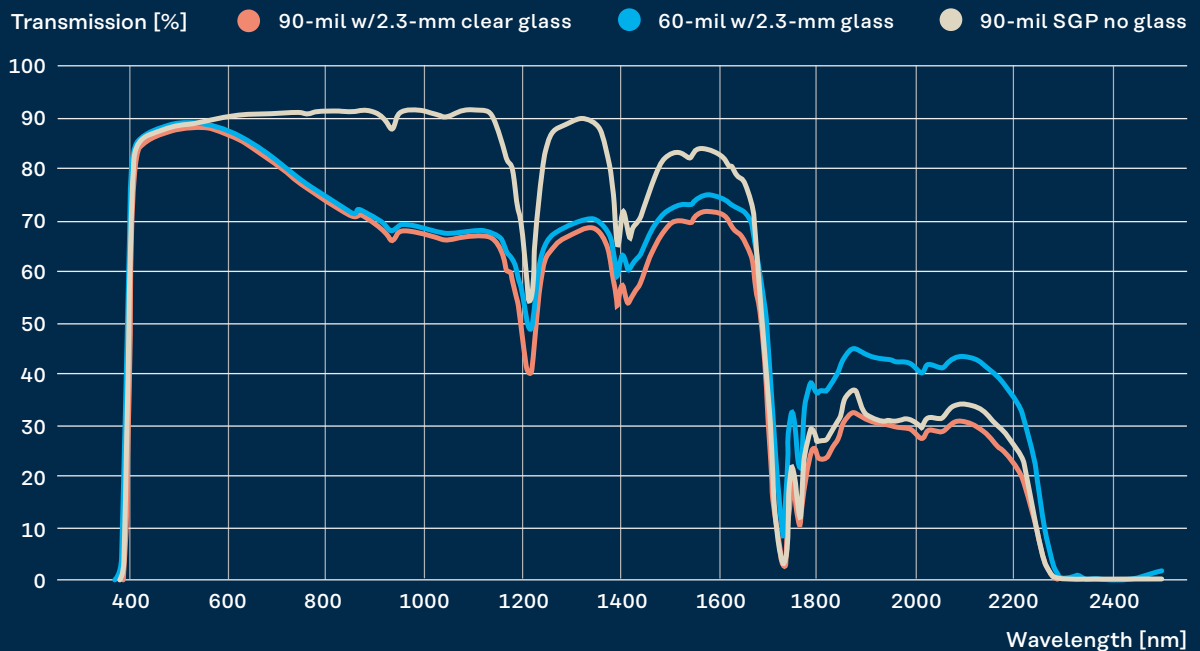

FIG 15 •

ADJUSTMENTS TO THESE PARAMETERS MAY BE NEEDED TO ATTAIN THE HIGHEST QUALITY PRE-PRESS:

- Laminate temperature exiting last roller: 63 ± 8 °C (145 ± 15 °F). Speed should be set to obtain the desired last roller exit temperature, which is based on prepress appearance. The optimum prepress should have a well-defined edge seal (clear along the entire perimeter).
- The prepress appearance for laminates made with IR nip roll lines should have a minimum of 19 mm (0.75") clear edge seal around the entire perimeter (2 cm). While the outside of edge of the laminate should be clear the interior will likely still be hazy (translucent) after prepressing due to residual surface pattern (see Figure 16). The optimum prepress temperature will be at the lower end of the recommended range.
- Convective furnaces tend to operate from the middle to upper range for the recommended glass temperature. The overall appearance will be mostly clear (see Figure 17).
- If a line of trapped air bubbles can be seen at the trailing edge of the prepress made on either a convective or IR line the laminate was most likely made at too high of a temperature resulting in a premature edge seal (see Figure 18).
- Roller pressure and opening:
 - 3 mm (0.125") less than total laminate thickness for annealed glass.
 - Decreasing the nip gap maybe necessary if using heat strengthened glass that contains roller wave.
 - Air pressure to the nip rolls should be 5 bar (75 psi) or greater.
 - Open up first nips if any glass slippage occurs

8.4.8. VACUUM BAG / RING PROCESS

Although using a vacuum ring or vacuum bag process is slower and more labor intensive than nip rolling it typically has better post autoclaving yields with respect to air related defects. It is the recommended process for making very large tempered laminates or multi-laminates. Disposable or re-usable systems can be used for vacuum bagging. Disposable types are hand constructed to the dimension of the laminate (Figure 19). It is necessary to use a porous strip along the edge of the laminate inside the plastic bag to allow complete de-airing of the laminate. To keep the edge of the interlayer smooth for open edge applications a gas permeable tape can be inserted around the perimeter of the laminate between the interlayer and the porous strip. If sticking occurs between the strip and the interlayer use of a perforated release film between the two is recommended. Any material used in vacuum processing a laminate with heat should be rated for this application.



FIG 16 • Proper edge seal IR

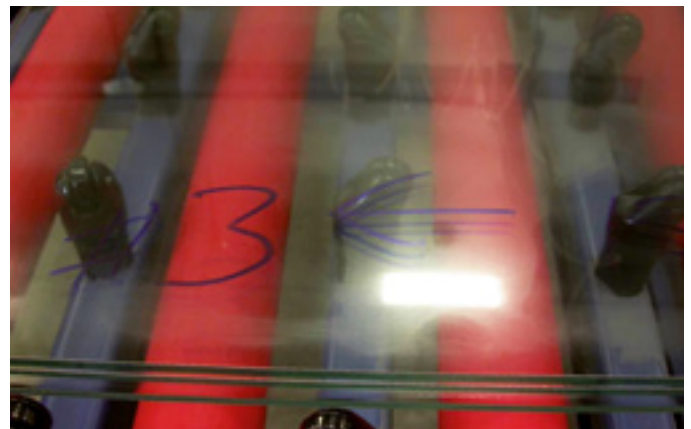

FIG 17 • Convective line prepress appearance



FIG 18 • Trapped air in trailing edge

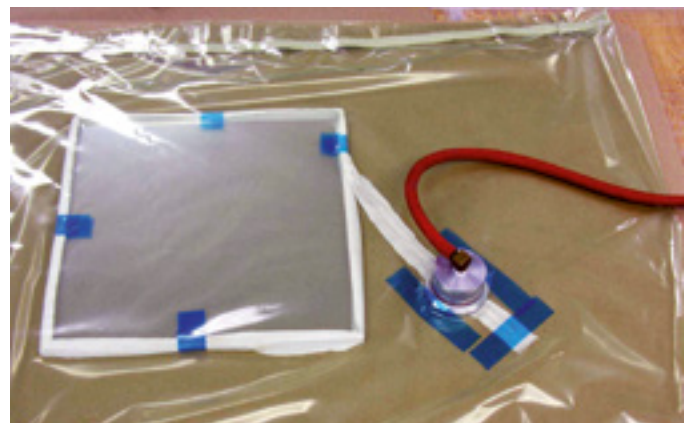

FIG 19 • Disposable vacuum bag

Re-useable systems include silicone rubber envelope bags (see figure 20) and clamshell assemblies (see figure 21). The cold vacuum time should be a minimum of 10 minutes. The hot vacuum temperature should be set based on the prepress appearance of the laminate. However, if desired, laminates can be made without the prepress operation by applying vacuum directly during the autoclave cycle, thus reducing handling and cycle time.



FIG 20 • Silicone rubber envelope bag (reusable)



FIG 21 • Clamshell assembly (reusable)

8.4.9. AUTOCLAVING

Control and monitoring of the autoclaving variables are essential to making quality laminates with SentryGlas® interlayer. Autoclave parameters including, prepress racking, soak time, soak temperature and cooling rate will influence both the optical and physical properties of the finished laminates. The laminates should be placed on the autoclave racks with ≥ 19 mm ($\frac{3}{4}$ ") spacing between pre-presses. Localized high stress areas need to be minimized by dispersing the load over a large area. Setting the laminate directly against the vertical rack supports should be avoided. Figure 22 is a photograph of laminates that have been racked improperly. Areas of uneven stresses (caused by placing laminates directly against some autoclave racks) can result in non-uniform interlayer thickness. This differential thickness can result in areas of high residual stress within the laminate and possible optical distortion. Figure 23 is a photograph taken with a polarized lens showing a laminate with optical distortion (iridescence), as a direct result of the autoclave racking conditions. Figure 24 is a photograph of the proper technique for racking pre-presses. The laminates are properly spaced with no airflow restrictions between the laminates.

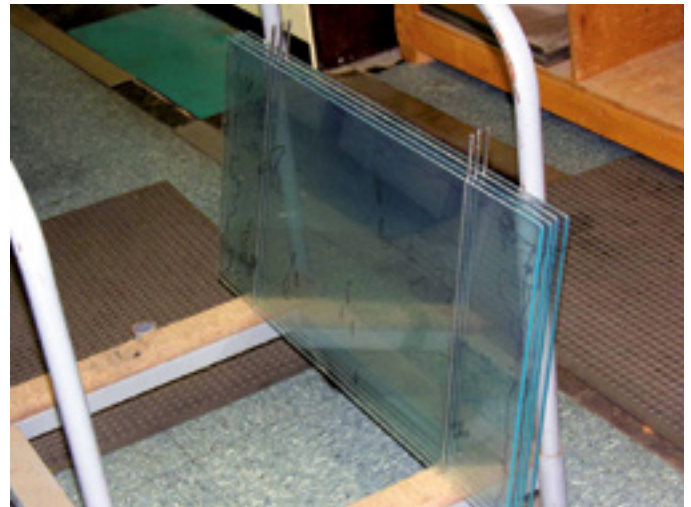

FIG 22 • Improperly racked laminates



FIG 23 • Laminate showing optical distortion

Autoclaves vary greatly with respect to size, heating, cooling rate and overall efficiency. The recommended soak temperature range is 132 - 135 °C (270 - 275 °F). It is imperative that the autoclave soak time be long enough so that the interlayer reaches the desired temperature for the required time to ensure adequate adhesion. The minimum recommended hold time is 1 hour. Laminates that do not receive the required time can look good optically but can have low adhesion due to incomplete bonding between the glass and the interlayer. Thicker laminate constructions (> 16-mm) will require a longer soak time. Imbedding a thermocouple in the exact construction to be laminated will give the most precise time versus temperature relationship. The amount of haze in the final laminate is directly related to the autoclave cycle cooling rate. The faster the cooling rate the lower the haze. To ensure adequate cooling that the following recommendations apply:

1. Use a properly sized fan.
2. Use cold or cool water with sufficient flow to maximize heat exchange.
3. Flush the radiator on a routine basis. Laminates with high haze can be re-autoclaved to reduce the haze level provided the cooling rate meets The recommended requirements.

THE RECOMMENDED AUTOCLAVE PARAMETERS ARE:

- **Temperature:** 132 - 135 °C (270 - 275 °F)
- **Pressure:** 12-14 bar (180-200 psi). **Note:** Lower autoclave soak pressures can be used however, the susceptibility of air bubbles forming in a laminate may increase with decreasing pressure.
- **Hold:** 60 minutes (or greater depending upon laminate thickness, autoclave size, load and airflow).
- **Cooling rate:** A minimum of 2.2 °C / min (4 °F / min). The cooling rate is critical to minimizing haze formation in the laminates. It is recommended that the laminates be near ambient temperature prior to shutting off both the fan and the cooling water.

To reduce the possibility of interlayer flow the maximum recommended autoclave temperature should not exceed 135 °C (275 °F). Figure 25 shows a typical autoclave profile used for SentryGlas® while Figure 26 shows one with a low pressure hold.

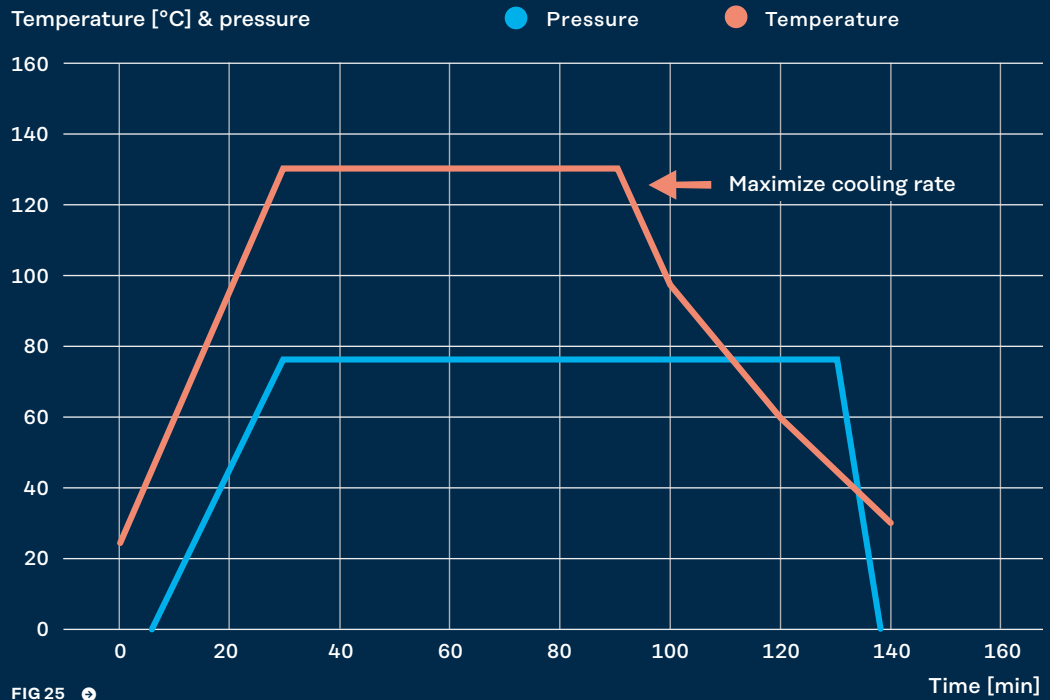

FIG 24 Properly racked laminates

Temperature Metric/Imperial

°C	°F
160	320
140	284
120	248
100	212
80	176
60	140
40	104
20	68
0	32

A. Basic SentryGlas autoclave profile



Pressure Metric/Imperial

bar	psi
16	232
14	203
12	174
10	145
8	116
6	87
4	58
2	29
0	0

B. Alternative SentryGlas autoclave cycle with low pressure step (in case cycle A is not sufficient)

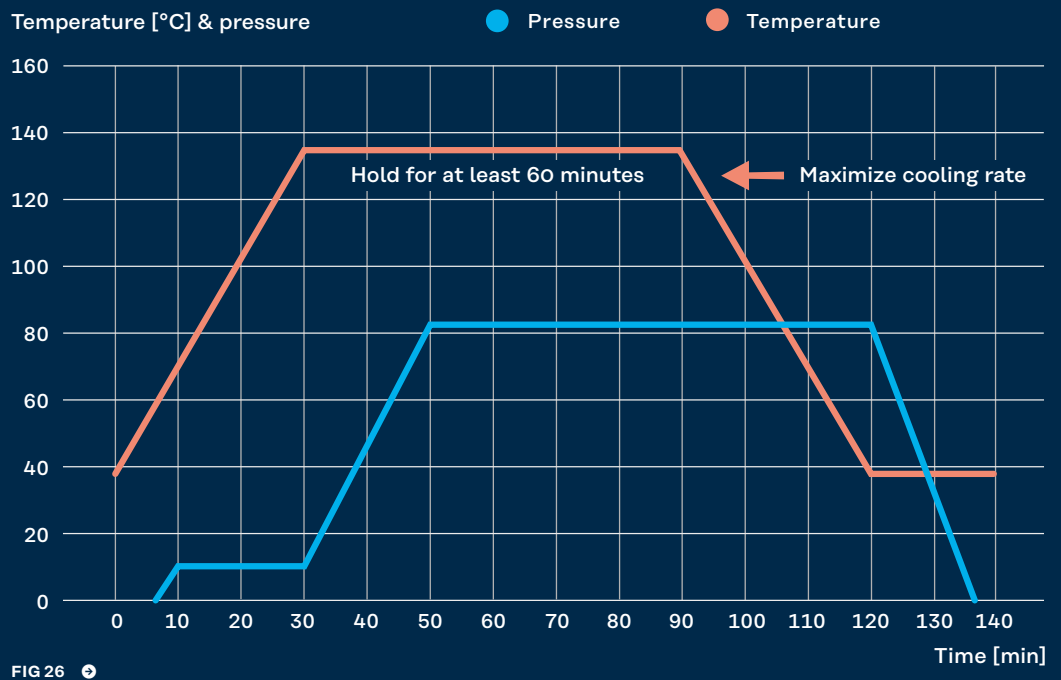

Temperature
Metric/Imperial

°C	°F
160	320
140	284
120	248
100	212
80	176
60	140
40	104
20	68
0	32

C. Alternative SentryGlas autoclave cycle with low pressure step and increased duration (in case cycle B is not sufficient)

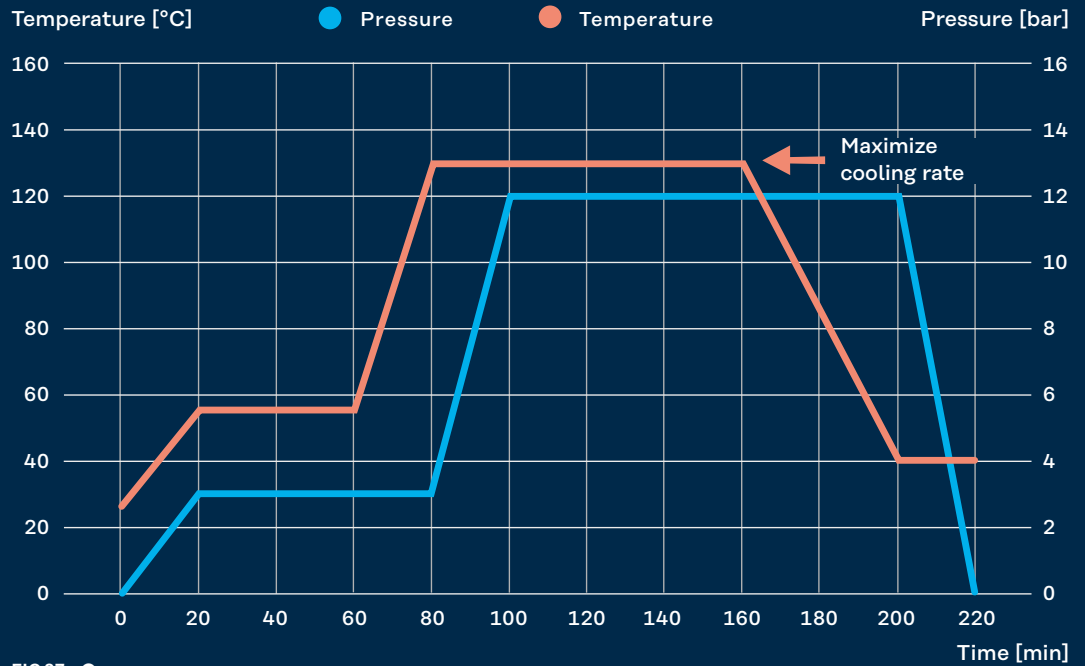

FIG 27

Pressure
Metric/Imperial

bar	psi
16	232
14	203
12	174
10	145
8	116
6	87
4	58
2	29
0	0

D. Special autoclave cycle for SentryGlas Multilaminates, big panes or intensive autoclave loadings

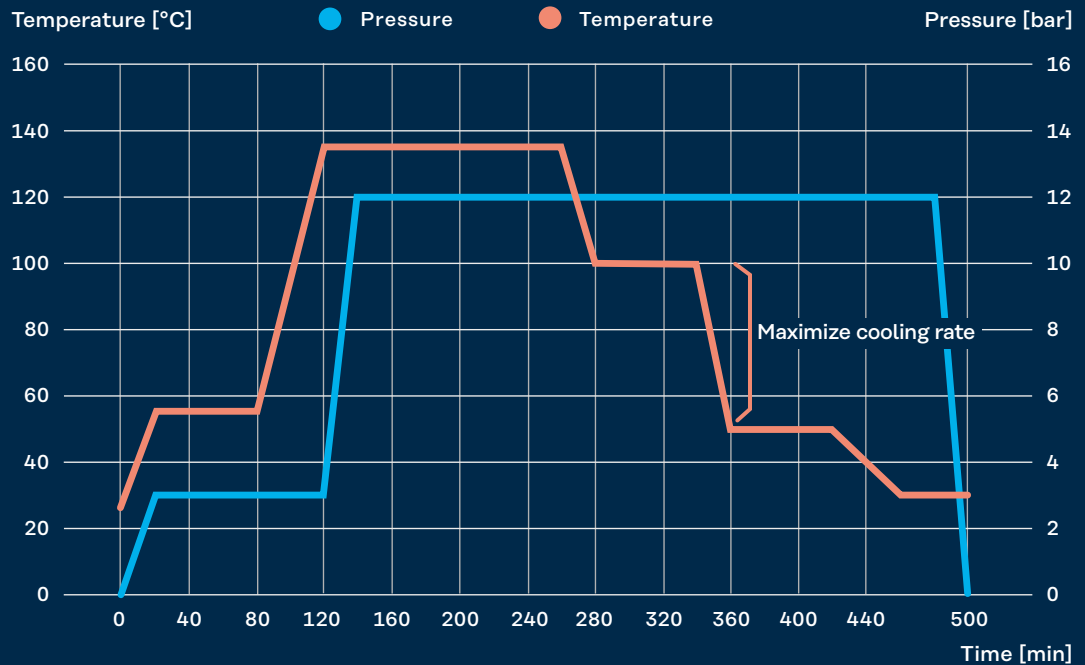

FIG 28

8.4.10. PROCESSING THIN 0.76 / 0.89 MM (30 / 35 MIL) SHEETING

Thin 0.76 or 0.89 mm (30 or 35 mil) SentryGlas®, whether on rolls or in sheets, requires some slight differences in processing versus 1.52 and 2.28 mm (60 and 90 mil) SentryGlas®. Laminating with heat-strengthened or tempered glass requires the lites to have good flatness with minimal roller wave and edge kink.

35-mil SentryGlas® 5000 water absorption Vs % RH at RT

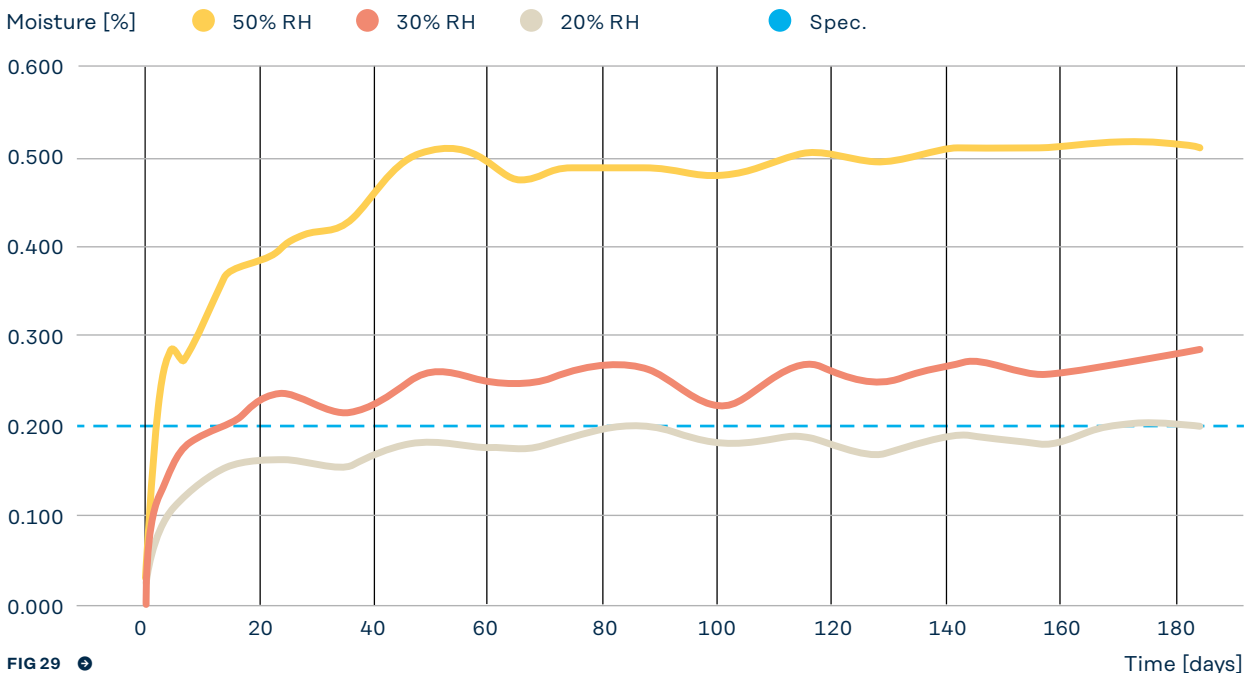

FIG 29 •

THE FOLLOWING ARE RECOMMENDATIONS FOR PROCESSING THIN SENTRYGLAS® VERSUS THE THICKER CALIPERS:

- Storage & Handling:** Due to the increased surface area versus bulk thin sheeting absorbs moisture at a faster rate. Figure 29 is a graph showing moisture absorption versus time for 3 different (20, 30 and 50 %) relative humidity.
- Cutting & Trimming:** Unlike the thicker calipers 0.89 mm (35 mil) sheeting can be easily trimmed at lay-up with a hook knife. For lamination with heat-strengthened or tempered glass it is recommended that 1/8 – 1/4" excess material be left at lay-up. Any residual interlayer should be trimmed after autoclaving.
- Cleaning:** A tacky roller is the best method to clean the sheeting. Using a glass washer to clean the sheeting is not recommended since it will likely get caught in the washer's brushes.
- Heated Treated Glass:** Heat strengthened or tempered glass needs to be flat with minimal roller and edge kink.
- Roller Processing:** The prepress appearance of a nip rolled 0.76 or 0.89 mm (30 or 35 mil) laminate should be similar to a 2.28 mm (90 mil) laminate. However, due to the less mass a slightly higher line speed maybe required.
- Autoclaving:** same as the thicker calipers

8.4.11. SENTRYGLAS® INTERLAYER MULTI-PLY SHEET LAMINATION

Achieving the desired laminate strength or projectile resistant properties may require laminating 2 or more sheets of interlayer together between two lites of glass. While any multi-ply sheet laminate can be vacuum bagged the nip rolling process window is limited.

NIP ROLL PROCESS

Laminating any two sheets of SentryGlas® together can readily be done using a standard nip roll process. Each sheet surface should be cleaned e.g. tacky rolled prior to lay-up to minimize contamination. Line speed should be set so that there is a well-defined clear edge seal without trapping air in the trailing edge of the prepress. Laminating more than 2 sheets together between 2 lites of glass can be successfully done provided the total interlayer thickness does not exceed 5 mm (200 mil). Nip rolling more than 2 sheets together when the total interlayer thickness exceeds 200 mil can result in:

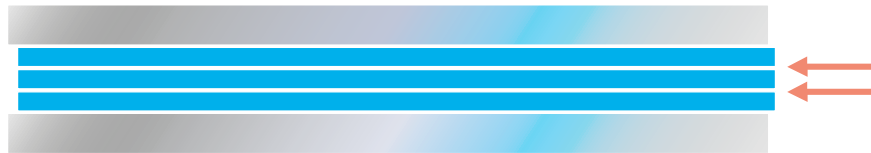

FIG 30

1. The internal SentryGlas® interlayer interfaces not getting enough heat to create a sufficient prepress bond resulting in pressurized air breaking the seal during autoclaving (see Figure 30).
2. Trapped air between the glass and the outermost interlayer ply when the prepress temperature is increased to improve the prepress bond between the internal SentryGlas® interlayer interfaces.

In addition to the flatness of the glass, successfully laminating more than two 2.28 mm (90 mil) sheets SentryGlas® together is dependent upon the type of line (IR versus convective), the parameters selected to run the line and the uniformity of heating within the prepress ovens.

VACUUM PROCESS

Vacuum lamination, if done correctly, will result in laminates without trapped air defects and is the preferred method for laminating more than 2 sheets of SentryGlas® together. The vacuum processing procedures remain the same regardless of the total interlayer thickness except for:

1. Cold de-airing time may need to be increased as the number of sheets increases. Since the required time is dependent upon process conditions (vacuum level, size of vacuum pumps, laminate size, etc.) it is recommended that optimum cold de-airing time be determined empirically.
2. As the size and thickness of both the interlayer and laminates increases the autoclave soak time should also increase proportionally.
3. To minimize haze ensure the laminate temperatures have cooled to below 100 °F prior to shutting off the fan and the cooling water in the autoclave

Please consult your Kuraray technical representative if there are questions regarding lamination of SentryGlas®.

8.4.12. WHEN AND HOW TO USE AN ADHESION PROMOTER

The use of adhesion promoter or primer increases the adhesion level of the interlayer to glass. The primer must be applied whenever the interlayer is not laminated against the tin-side of the glass. It is requested that Kuraray be consulted if there are any questions regarding the use or application of a primer. The adhesion promoter can either be made by the laminator (see instructions below) or purchased as a premade solution. Contact a Kuraray account manager or technical representative regarding vendor purchase information.

SOLUTION PREPARATION

The active ingredient in the primer recipe is gamma-aminopropyltriethoxysilane. Trade names using this chemical formulation include in part; Silquest A-1100 and Dow Corning Z6011. In Europe sample bottles of the amino-silane can be purchased from Sigma Aldrich.

(<https://www.sigmaaldrich.com/DE/de/product/sial/a3648>).

The recipe can be made either of two ways: the first is the standard recipe and the second (modified recipe) that utilizes more common ingredients. The respective recipes, shown in the spreadsheets below, each require only a small percent of the γ -aminopropyltriethoxysilane to attain high adhesion. Please note if using the modified recipe to ensure that the isopropyl alcohol and vinegar are high purity do not contain additives. Since the solution is flammable it should not be stored or applied next to heat or an ignition source. Ensure all MSDS recommendations for the amino-silane, acetic acid, and 2-propanol are followed prior to making the solution. The primer should not be used until 24-hrs after mixing to allow the amino silane time to fully hydrolyze. The solution can be stored in a plastic or a glass container for up to 4-months before it needs to be replaced.

Adhesion promoter recipe

Ingredient	Weight [%]
2-Propanol	92.00
Water	7.90
Acetic Acid	0.01
γ -aminopropyltriethoxysilane	0.09
Total	100

TAB 56 •

Adhesion promoter modified recipe

Ingredient	Weight [%]
Isopropyl alcohol	89.92
Water	8.47
Vinegar	1.5
γ -aminopropyltriethoxysilane	0.11
Total	100

TAB 57 •

PRIMER APPLICATION

The adhesion promoter should be applied to the glass not the interlayer. There are a number of different methods that can be used to apply the solution. Including

1. **Misting from a spray bottle then wiping dry**
2. **Wiping the glass with a lint free wipe that was pre-dampened with solution**
3. **Using a commercial applicator**

but not restricted to:

For optimum results the solution should be applied lightly to prewashed glass in the lamination clean room. When using a spray bottle the solution should be misted only to the glass surface that will be adhered to the SentryGlas®. After applying, the solution should be wiped dry ensuring the total surface of the lite has been covered. Applying the primer too heavily can result in a decrease in adhesion. Lay-up can be done immediately after the application is completed. All standard lamination processes (nip rolling, vacuum bagging, etc.) can be utilized.

8.4.13. SENTRYGLAS® INTER-LAYER LAMINATED TO MORE THAN 2 LITES OF GLASS (MULTI-LAMINATES)

Laminating SentryGlas® to more than two lites of glass will require that at least one surface of interlayer to contact the airside of the glass. All airside glass surfaces that are laminated against the interlayer **must** be primed with an adhesion promoter (see 8.2.12.). Nip rolling is not recommended for applications that exceed three lites of glass and 2 sheets of interlayer.

8.4.14. LAMINATING WITH POINT FIXATED GLASS (HOLES)

SentryGlas® does work well for point fixated systems i.e., laminates with holes provided the laminates are made correctly. Nip rolling versus vacuum bag processing is dependent upon the size, thickness and total amount of glass and/or interlayer plies required.

NIP ROLL

SentryGlas® interlayer with holes can be processed with high yields using a nip roll process without the use of clamps. In addition, success can be achieved by either removing the interlayer from the holes before or after autoclaving.

The most common problem for yield loss after autoclaving in point fixated laminates with SentryGlas® is trapped air adjacent to the holes (see figure 31).

This is most often caused not by trapping air in during prepressing but by pressurized air breaking the edge seal during autoclaving. Autoclave “blow-ins” occurs due to insufficient edge seal around the hole. A high amount of uniform haze (residual surface pattern) around the hole is a result prepressing too cold (see figure 32).

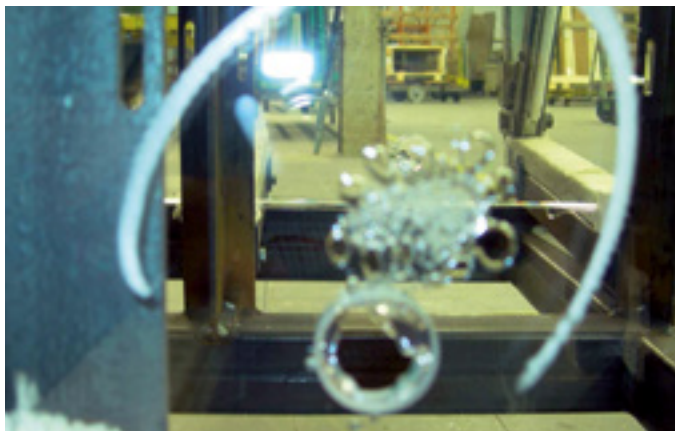

FIG 31 Air near hole



FIG 32 Prepress too cold

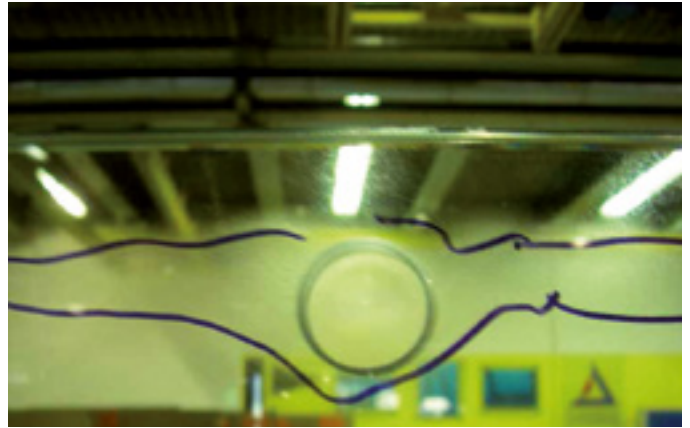

FIG 33 Non-uniform prepress haze

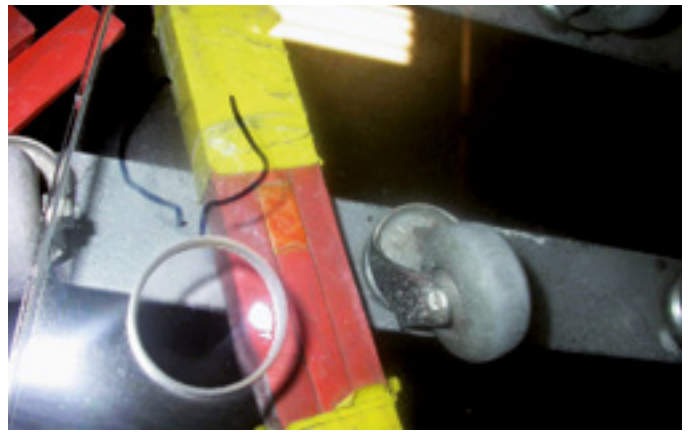

FIG 34 Proper prepress

This can be corrected by running the prepress at a lower line speed. Non-uniform prepress haze around the hole is typified by having areas around the perimeter that are both clear and hazy (see figure 33). This is more difficult to rectify since it can be related to lack of flatness in the glass or variable heating across the laminate. Figure 34 shows the desired appearance of a prepress with a clear edge seal around the entire perimeter of the hole.

Removing the interlayer from the hole can be done either after prepressing or after autoclaving. While there are a number of methods for doing this one of the quickest and easiest methods is using a core or hole bit to drill out the SentryGlas® (see figure 35). The drill bit diameter should be slightly less than the hole diameter to minimize contact with the glass.

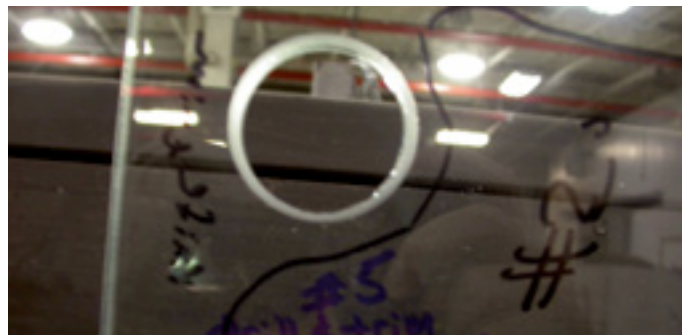

FIG 35

Figure 34 shows a hole drilled after prepressing. Since the interlayer is hot coming directly from the oven it is best to allow some cooling to prevent sticking of the interlayer to the drill bit. After drilling, the remaining interlayer will need to be removed with either an exact blade or a hot knife (model ZTS 20 for example). The advantage of trimming the SentryGlas® interlayer flush after prepressing is that it is easier to remove since it is less stiff.

Good quality prepresses require **no clamps** during autoclaving. In addition, on precut holes there should be no flow of the interlayer from the hole during autoclaving thus no additional hole trimming should be required. Outward flow results in thinning of the interlayer which can result in delamination. To help prevent this ensure the soak temperature does not exceed 135 °C (275 °F) and there are no high stress areas pressing on the laminates. Minimizing distortion (roller wave, edge kink, etc.) is important. If there is flow of the SentryGlas® into the laminate leading to “short vinyl” around the hole perimeter this is typically a result of: a) excessive void space due to tempering distortion or b) thinning caused by pulling too hard on the soft interlayer during trimming. If this is observed post autoclaving hole drilling should rectify the problem.

The process for hole drilling and trimming before versus after autoclaving is the same. However, after autoclaving more force is required for trimming due to the increased stiffness.

NIP ROLL PROCESS SUMMARY

1. Core drilling out the SentryGlas® works well either before or after autoclaving.
2. Core drilling after prepressing works best if the interlayer is allowed to cool partially before drilling.
3. Trimming the holes flush to the glass should be done using either an exact knife or a hot knife after core drilling is completed. Use of a torch is not recommended.
4. Clamps should not be used.
5. No flow of the interlayer out of the holes should occur during autoclaving thus inserting tape or other substances into the hole restrict flow of the interlayer should not be needed.
6. If the interlayer becomes recessed into the glass consider trimming after autoclaving.

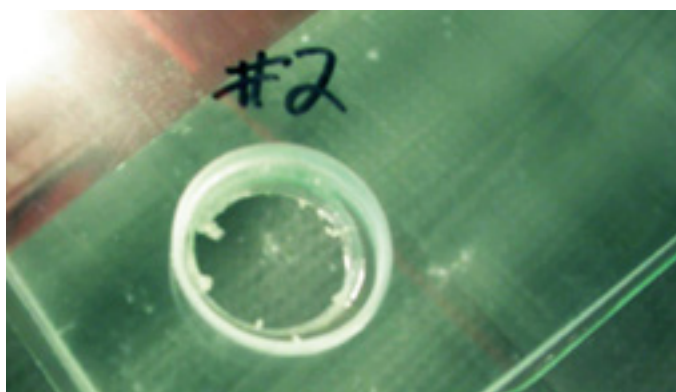

FIG 36 • Drilled hole after prepressing

8.4.15. VACUUM BAGGING

For large thick tempered laminates or multi-ply glass panels vacuum bagging the laminates with SentryGlas® with holes is recommended to maximize yields. The vacuum bag process for laminates with holes is similar to that of standard laminates (no holes) except for the addition of a few extra steps.

It is recommended that in a vacuum process the interlayer not be removed the holes until after autoclaving to minimize flow into the laminate i.e. “suck-in”. The porous breather material to promote de-airing should be placed over each hole on the top and bottom of each prepress and taped in place (see figure 37) to prevent getting sucked into the hole. After autoclaving the interlayer can be removed from the holes using a core drill and a knife.

The remaining steps are the same as processing laminates without holes. An outline of the best practices of laminating SentryGlas® with holes in a vacuum bag process is listed below.



FIG 37 • Breather material over hole

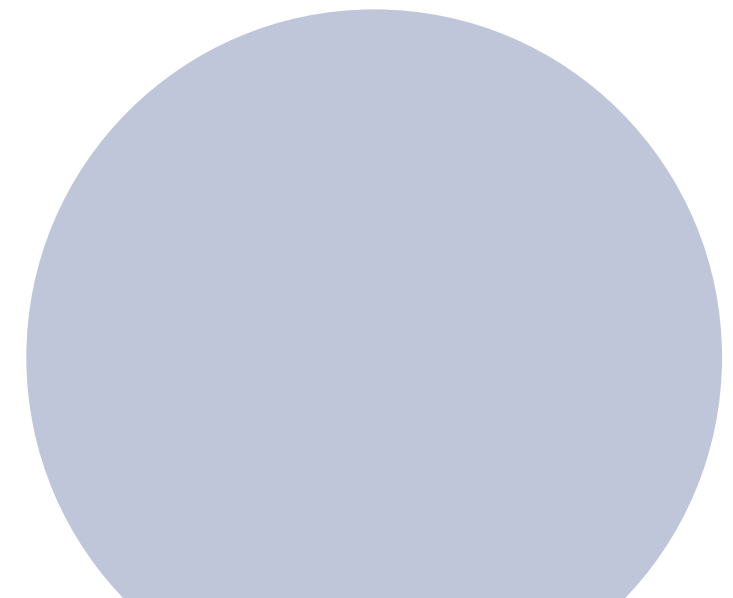

VACUUM BAG PROCESS OUTLINE

1. The construction of the laminate needs to be ATTA. Since this is not possible for multi-layers the number of interfaces the interlayer has to tin side of the glass should be maximized.
2. For projects that have asymmetrical shapes or point fixated designs (holes) controlling construction will require orientating the glass correctly during glass fabrication (drilling, beveling, etc.). It is requested that project drawings include the ATTA requirement and designate the proper side of the glass for fabrication.
3. All airside glass surfaces that are laminated to the SentryGlas® should be adhesion promoted (see section 12).
4. Depending on the size of the laminates, the amount of distortion in the glass and the thickness of the SentryGlas® the interlayer may need to be cut up to 5-mm oversized in length and width to allow for flow-in during autoclaving.
5. To maximize de-airing channels a porous breather material is needed along the entire glass/interlayer interface including holes. It is strongly suggested that the breather material be securely adhered to the outside of the glass using a high temperature rated tape. This will prevent the breather material from recessing into the laminate when under vacuum.
6. For large laminates maximizing the number of vacuum connections will improve de-airing efficiency.
7. To properly de-air the prepress it is important to maximize the vacuum level. It is recommended that the vacuum be $\geq 28''$ Hg (93 % vacuum or 948 mbar).
8. Cold de-airing in the autoclave should be at least 60 minutes for large multi-ply laminates.
9. Autoclave soak time should be increased from 60 to 90 mins (or longer depending upon total laminate thickness) at 135°C (275 °F) for large multi-ply laminates.
10. The interlayer should be removed from the holes after autoclaving with a core drill and then trimmed flush using an *exacto* or hot knife. Use of a torch is not recommended.

8.4.16. COMPATIBILITY OF SENTRYGLAS® WITH COATED GLASS OR FRITS

Typically, SentryGlas® has very good adhesion to coated glass or ceramic frits. Contact your Kuraray account manager for an updated list of coatings that have been evaluated or check our website

<http://www.trosifol.com>

It is recommended that any low-e coating or frit not on the list be tested for adhesion and compatibility. If possible, the frit should be applied to the tin side of the glass. If the frit must be applied to the air side of the glass and does not have 100 % coverage an adhesion promoter should be used. It is requested that sample laminates with and without adhesion promoter be sent to Kuraray for evaluation.

8.5. SentryGlas® Translucent White (TW) interlayer

SentryGlas® TW interlayer is one of the latest innovation by Kuraray combining the market proven strength and performance of clear SentryGlas® interlayers with the option of color. It provides the architectural community additional design options; offering uniform color with an opacity that allows for more diverse design options. Suited for commercial as well as residential applications, SentryGlas® TW interlayer will help to add a more dramatic lighting effect to any space; providing exceptional aesthetics, added privacy, and excellent daylighting, for interior and exterior laminated glass applications.

A visible light transmittance (Tvis) of 80% is achieved using one layer in the laminate. The 65 % Tvis is achieved by stacking two plies of 0.80 mm (31 mil) interlayer together during the lamination process. The result is an approximate overall interlayer thickness of 1.52 mm.

SentryGlas® TW light transmission

Sheets	Caliper	ASTM 1003 LT [%]	EN 410 LT [%]
1 ply	0.80 mm (31 mil)	80	73
2 plies	1.60 mm (62 mil)	66	57
3 plies	2.40 mm (93 mil)	50	

TAB 57 • Note: For optimum optics, when plying multiple layers always ply translucent white SentryGlas® with itself or with NUV SentryGlas®. Never use with standard clear SentryGlas®



• 66 % light transmission



• 55% light transmission

SentryGlas® TW spectral performance vs. SentryGlas® NUV

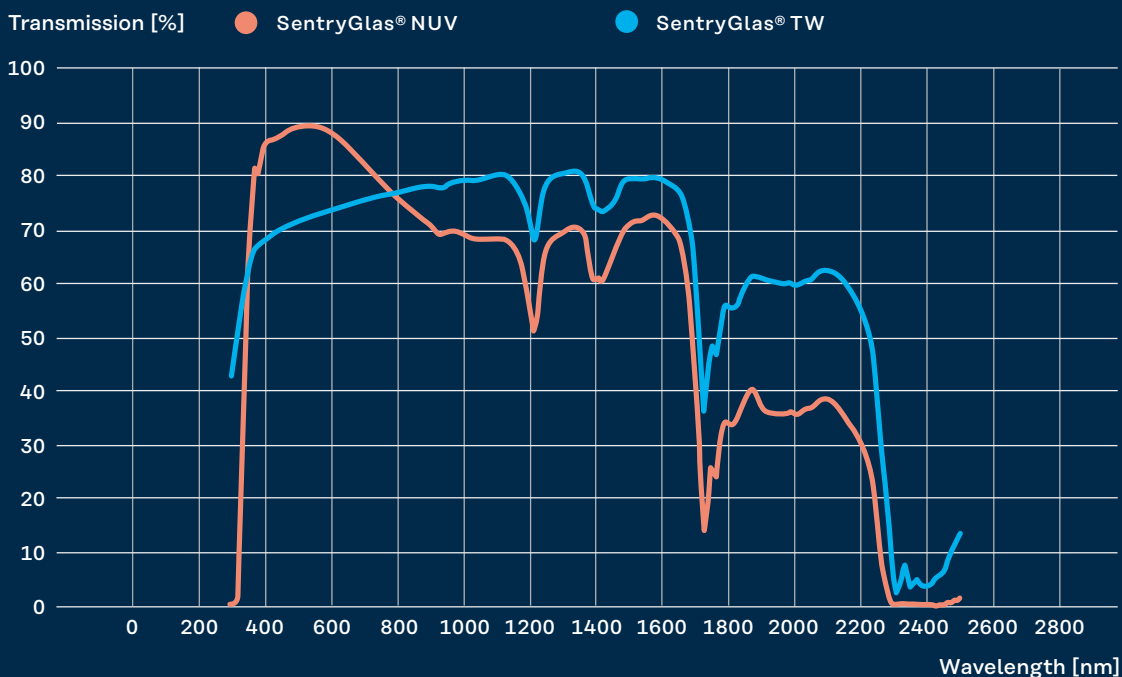

Using only one ply may result in failure to meet the impact requirements for safety glazing certification like EN ISO 12600. Handling, storage and lamination for white is the same as 0.89 mm (35 mil) clear SentryGlas® interlayer on rolls. If a translucent white laminate requires an interlayer thickness greater than 1.52 mm (60 mil) the addition of clear SentryGlas® will be needed. **Translucent White must be**

laminated only in combination with high UV transmission clear SentryGlas® (NUV5000 or NUVR5000, see this chapter for product descriptions) to maintain the color over time. The clear SentryGlas® interlayer containing UV absorber (SG5000 and SGR5000) should never be used in direct contact with white SentryGlas®. Please consult your Kuraray account manager if a light transmission other than 65 % is desired.



➔ College Football Hall of Fame, Atlanta (USA)

Photo: Atlanta Hall Management, Inc.

8.6. SentryGlas® Natural UV (NUV)

The standard clear SentryGlas® contains an ultra violet light (UV) absorber. SentryGlas® Natural UV is a structural interlayer for safety glass that combines the strength, safety and edge stability of SentryGlas® interlayer with increased transmittance of natural ultraviolet (UV) light. Unlike most safety glass interlayer technologies, SentryGlas® ionoplast requires no UV protection for lasting strength and clarity. SentryGlas® interlayer can be manufactured in a special, high UV-transmittance sheet, which is suitable for use in botanical gardens or other special environments where exotic plants, fish, reptiles and insects demand unique UV light requirements. Using SentryGlas® Natural UV interlayer with float glass or low-iron float glass can dramatically increase the UV-transmittance through the resulting laminated glass panels.

The UV-transmittance level of a glass laminate is highly dependent on the transmittance level of the chosen glass at the required thickness for a given structure. Generally, by specifying SentryGlas® Natural UV over other types of laminated glass, the level of UV light transmittance is inherently higher due to the reduced glass thickness required. High levels of UV-A and UV-B light pass through a SentryGlas®

Natural UV interlayer. However, other glazing materials, including monolithic glass, block out much of the UV-A and UV-B energy. The processing is the same for both high and low UV absorbing interlayers.



• American Dream Mall, East Rutherford, New Jersey

UV light transmittance curves

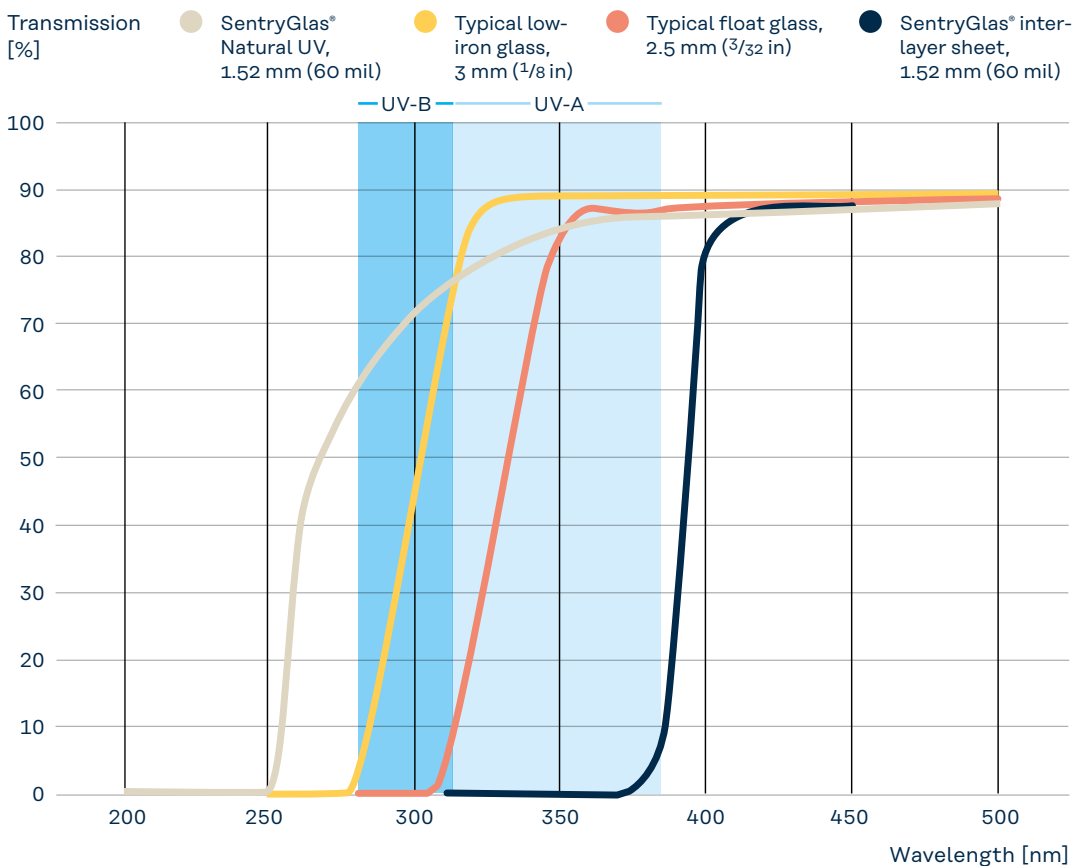

8.7. SentryGlas® jumbo size up to 330cm

SentryGlas® film in the past was only produced in rolls with a maximum of 2700 mm width by 0.76 mm and 0.89 (30 and 35 mil) thickness. For Jumbo size laminated glass the technology welding/fusing and cutting of SentryGlas® rolls to any width was necessary. The fused film is processed in conventional lamination equipment. The main problem of fusing 2 sheets is the possible visibility of joints after autoclave process. With the supply of the maximum possible roll width 3300 mm ("Jumbo size") from the year 2021 Kuraray closes the gap in the delivery forms compared to PVB interlayers.



• SentryGlas® rolls in width 330 cm (Jumbo size)

8.8. SentryGlas® Xtra™ (SGX™)

SentryGlas® Xtra™ (SGX™) is the latest generation SentryGlas® ionoplast interlayer from Trosifol designed to improve lamination performance and efficiency.

SGX™ has robust adhesion to the air side of glass without the need for primer making lamination of multi ply laminates easier. SGX™ optical performance and haze formation are much less sensitive to the autoclave cooling rate giving peace of mind to the laminator that the final laminate will have consistently high quality. The lower haze also makes producing very thick laminates of outstanding optical quality easily achievable.

SentryGlas® Xtra™ is currently offered in sheet form and in roll form up to 330 cm. The sheets are shipped on a pallet in hermetically sealed foil bags to protect the interlayer from moisture and contamination. The foil package is encased in cardboard to prevent damage that can occur during shipping.

SGX™ complies with global safety glazing codes such as ANSI Z97.1, EN 14449, EN 12543, EN 12600, EN 356 and Safety Glazing Certification Council (SGCC). Properly laminated and installed SGX™ laminates of 2.53 mm (100 mil) caliper have been tested and pass the large missile impact test per ASTM E 1996.

8.8.1. HANDLING AND STORAGE

Unopened sheeting require no temperature control for storage because SentryGlas® Xtra™ does not “block” like PVB does. SentryGlas® Xtra™ interlayer sheeting maintains its proper- ties and overall quality consistency for many years under moisture proof storage conditions. Since moisture pick up over time can lead to deterioration in glass adhesion performance, it is recommended that SentryGlas® Xtra™ interlayer sheets in unopened packages be tested for moisture level and post-lamination adhesion performance if the product is stored beyond three years from its original manufacturing date. SentryGlas® Xtra™ will however, absorb

water when opened packages are exposed to ambient conditions. While the water absorption rate is very slow compared to PVB, water absorption of SentryGlas® Xtra™ will adversely affect adhesion. It is recommended that the interlayer not be used if the moisture exceeds 0.2% (when measured by Karl Fischer titration). Figure 1a-c are the graphs showing water absorption rate our three calipers exposed to 27%, 50% and 75% relative humidity respectively. Upon opening, all packages of SentryGlas® Xtra™ need to be properly resealed. The further procedure of handling, cutting& trimming as well as sheet cleaning is already described in chapter 8.4.2. and 8.4.3.

SentryGlas® Xtra™ moisture uptake at 27% RH

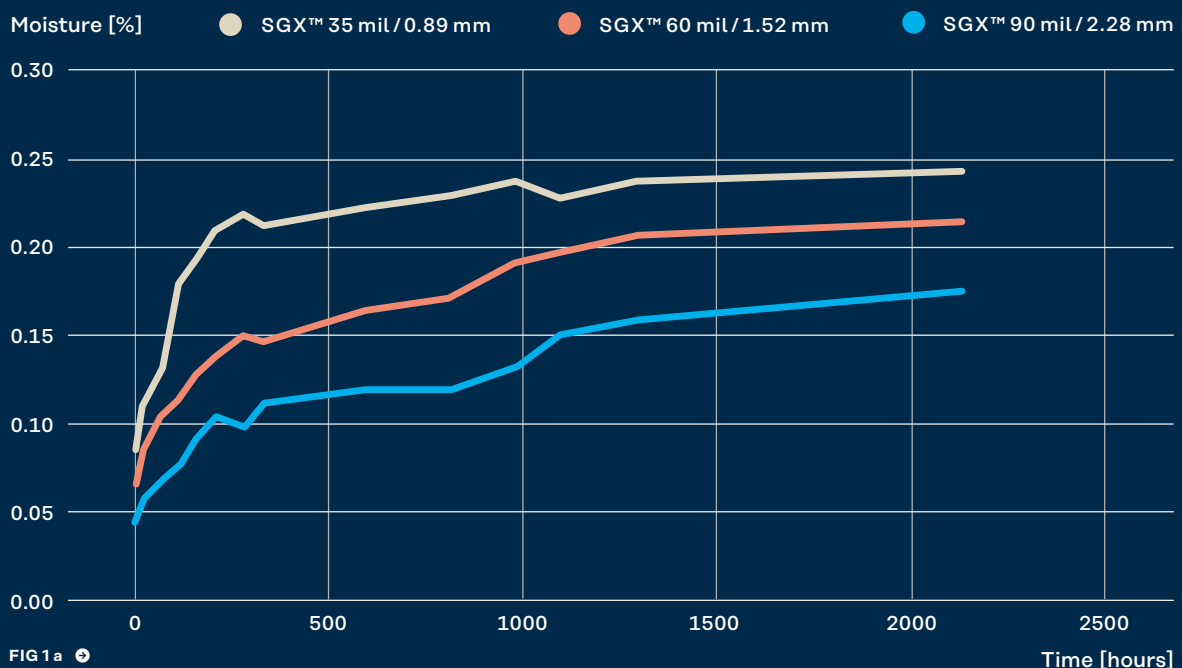

SentryGlas® Xtra™ moisture uptake at 50% RH

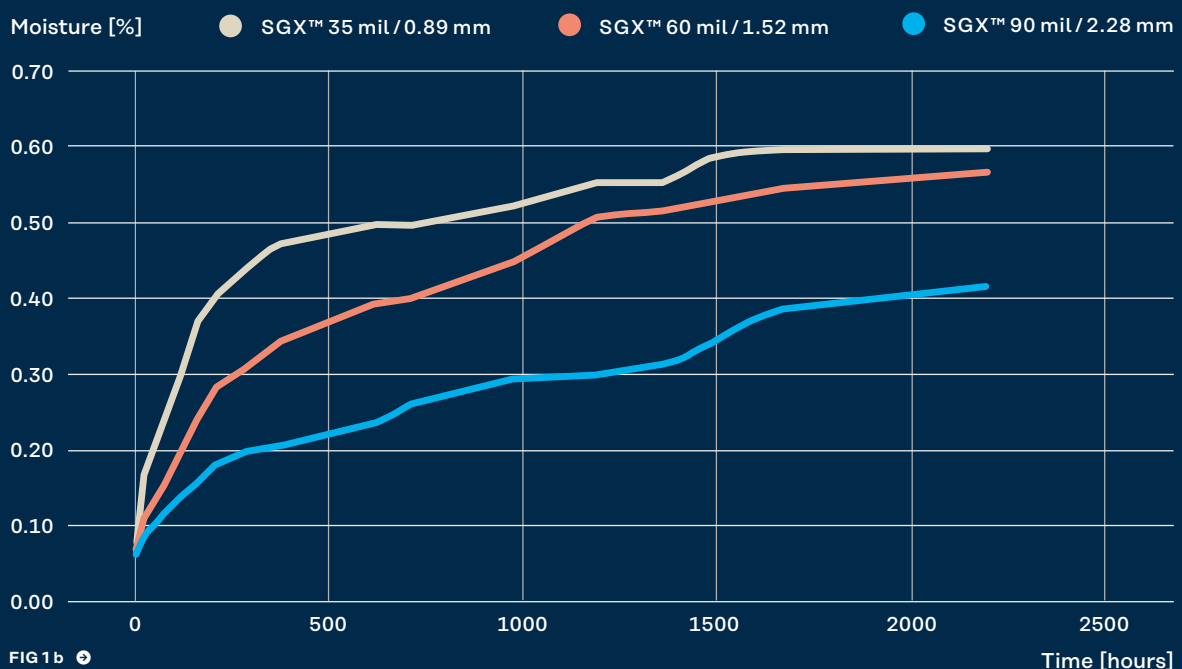

SentryGlas® Xtra™ moisture uptake at 75% RH

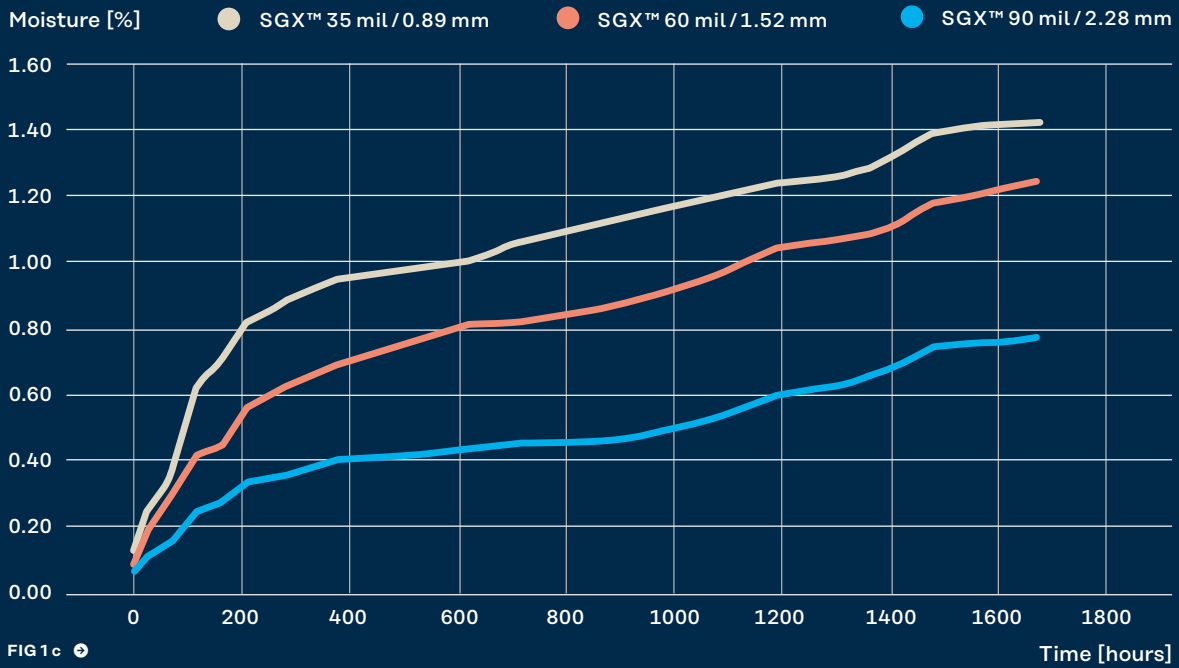

8.8.2. ASSEMBLY

Before assembly, ensure that the glass is dry. SentryGlas® Xtra™ can be laminated *with high adhesion to either the tin-side or the airside of the glass*. No adhesion promoter is needed and one should not be used. SentryGlas® Xtra™ does not tack to the glass at lay-up. This makes glass repositioning easy; however, there is an increased potential for glass slippage.

8.8.3. ROLLER PROCESS

The principle process conditions are already described in chapter 8.3.7. For the IR absorption of SentryGlas® Xtra™ there are slightly different transmission curves to Standard SentryGlas® for 3 different calipers as shown in Figure 2.

SentryGlas® Xtra™ total solar transmission curves

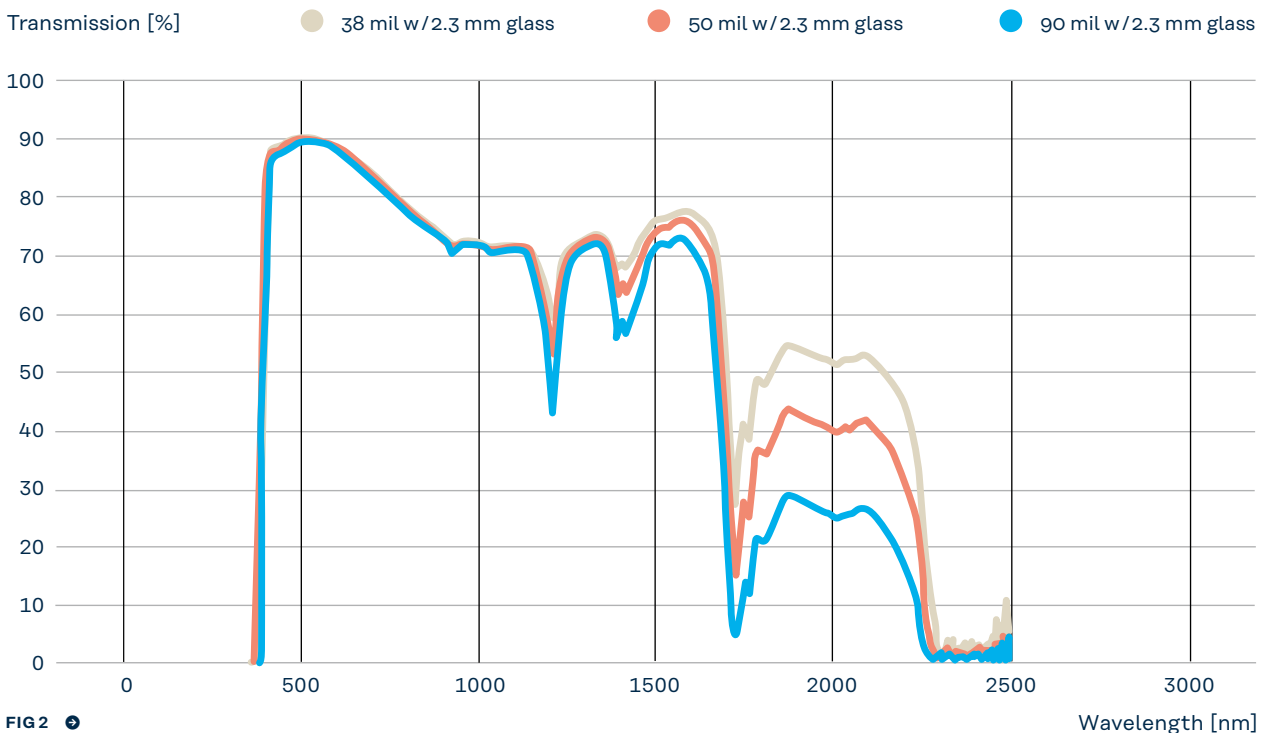

8.8.4. AUTOCLAVING

SentryGlas® Xtra™ haze in the laminate is less sensitive to the autoclave cooling rate. Figure 3 shows the comparison between the 2 ionoplast interlayer types. This lower sensitivity has other benefits like:

- Less risk of haze forming in general
- Reduce need to re-autoclave for haze
- Can increase autoclave density
- Higher confidence in final laminate optical properties

Another advantage is the higher glass adhesion level of SentryGlas® Xtra™ to the glass air side and a less moisture sensitivity of adhesion on both glass sides, as shown in Figure 4.

The pummel adhesion with both ionoplast interlayer types is conducted at room temperature vs. defined reference samples.

Haze less sensitive to autoclave cooling rate SentryGlas® Xtra™ vs. SentryGlas®

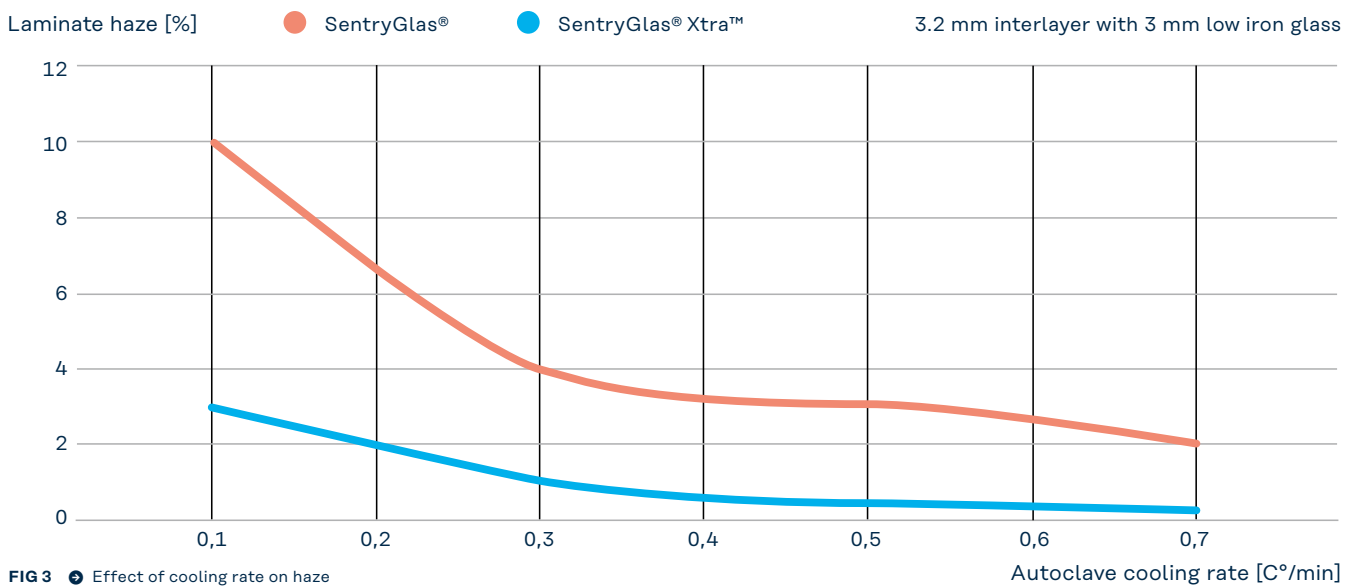

FIG 3 • Effect of cooling rate on haze

Pummel adhesion comparison SentryGlas® vs. SentryGlas® Xtra™

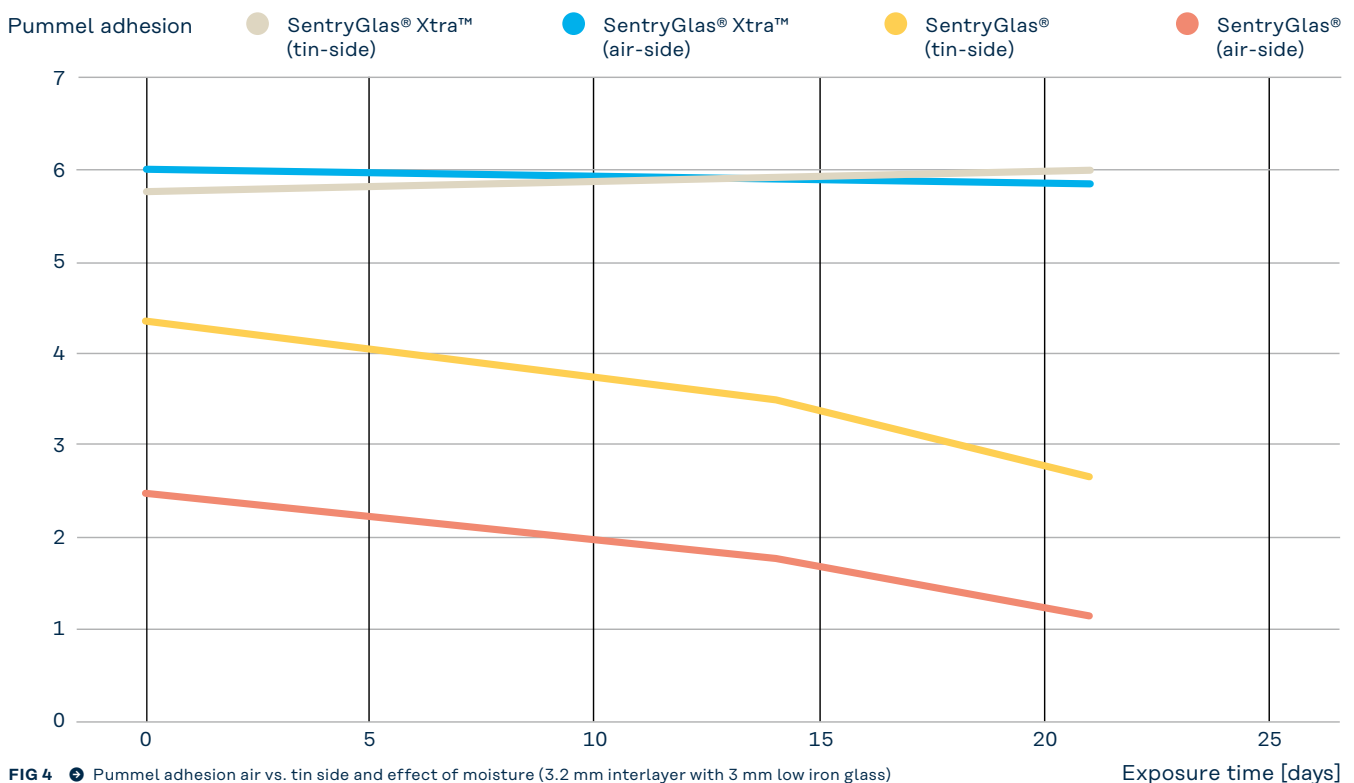

FIG 4 • Pummel adhesion air vs. tin side and effect of moisture (3.2 mm interlayer with 3 mm low iron glass)

THE RECOMMENDED AUTOCLAVE PARAMETERS ARE:

- Temperature: 120 - 130 °C (250 - 267 °F) nominally 125 °C (257 °F).
- Pressure: 10 -14 bar (150 -200 psi). Note: Lower autoclave soak pressures can be used however, the susceptibility of air bubbles forming in a laminate may increase with decreasing pressure.
- Hold: 45 minutes (or greater depending upon laminate thickness, autoclave size, load and airflow).
- Cooling rate: A minimum of 1 °C / min (2 °F / min). The cooling rate can impact haze formation in the laminates. It is recommended that the laminates be near ambient temperature prior to shutting off both the fan and cooling water.



Temperature Metric/Imperial

°C	°F
160	320
140	284
120	248
100	212
80	176
60	140
40	104
20	68
0	32

Typical autoclave cycle

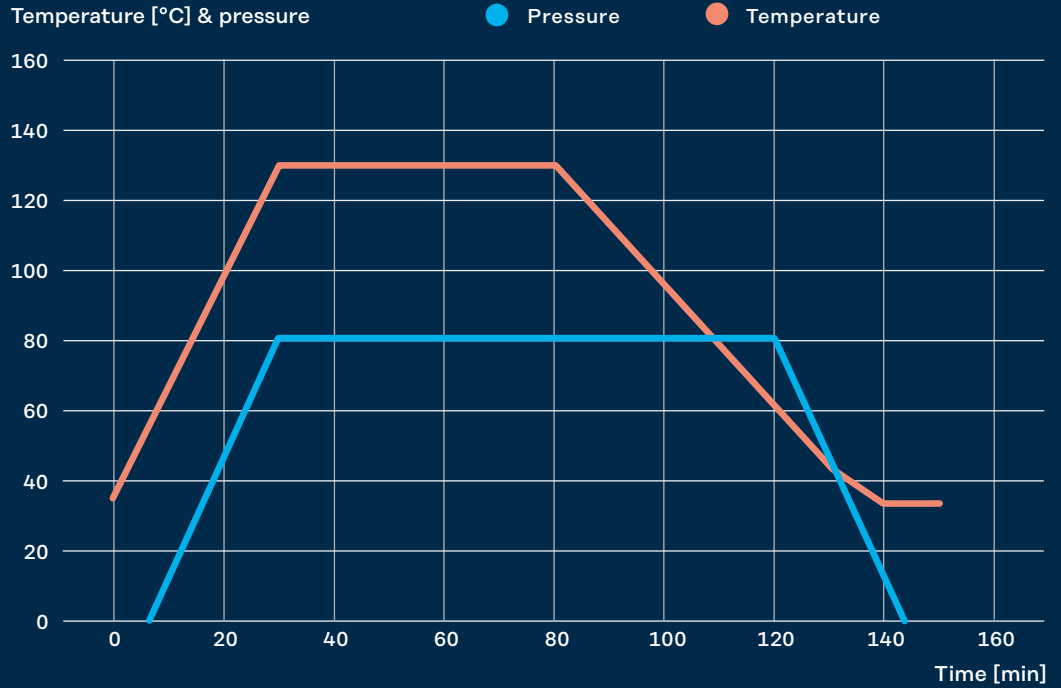

FIG 5

Pressure Metric/Imperial

bar	psi
16	232
14	203
12	174
10	145
8	116
6	87
4	58
2	29
0	0

Low pressure hold autoclave cycle

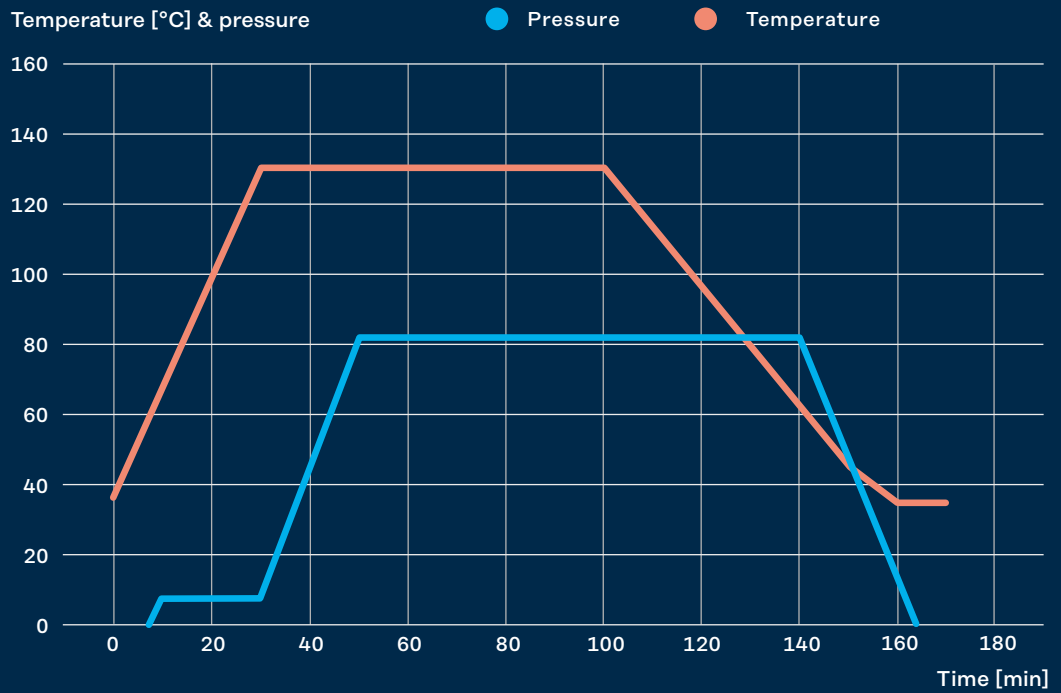

FIG 6

8.9. Stiffness and Elastic properties of SentryGlas® Iono-plast interlayer vs. Trosifol® Clear

Originally developed for glazing in hurricane zones, SentryGlas® ionoplast interlayers are significantly stiffer than standard PVBs such as Trosifol® Clear.

8.9.1. STIFFNESS AND ELASTIC PROPERTIES

If two sheets of glass, lying on top of one another, are placed under load, they will start to bend (distort) independently. Displacement occurs between the two inner surfaces, which are in direct contact with each other. This is because one of the two surfaces is being stretched while the other is being compressed. If both sheets are laminated with an adhesive polymer interlayer, this must be able to internally compensate for the distortional differences (i.e. absorb shear forces).

8.9.2. MEASUREMENT OF STIFFNESS AND ELASTIC PROPERTIES

Most laminated safety glass interlayers are viscoelastic. Viscoelasticity is the property of materials that exhibit both viscous and elastic characteristics when undergoing deformation. Viscous materials resist shear flow and strain linearly with time when a stress is applied. Elastic materials strain when stretched and quickly return to their original state once the stress is removed. Viscoelastic materials therefore have elements of both of these properties and as such exhibit time-dependent strain.

Important material design values for the calculation of stresses and deformations are represented by the elastic constants, i.e. the modulus of elasticity (Young's Modulus) and Poisson's ratio. The modulus of elasticity, which by definition can be used as a direct comparison parameter for material stiffness, shows a dependence on the material and temperature.

Shear modulus or modulus of rigidity is defined as the ratio of shear stress to the shear strain. Shear modulus' derived SI unit is the pascal (Pa), although it is normally expressed in Megapascals (MPa), or in thousands of pounds per square inch (ksi).

The shear modulus is always positive. Young's Modulus describes the material's response to linear strain. The shear modulus describes the material's response to shearing strains.

Stiffness (Young's Modulus and shear modulus) and Poisson ratio vary as a function of temperature and load duration (creep).



➔ Museo Jumex, Mexico

Photo: © Museo Jumex, Mexico

Comparison of short-term stiffness and strength of Trosifol® Clear and SentryGlas® Interlayers

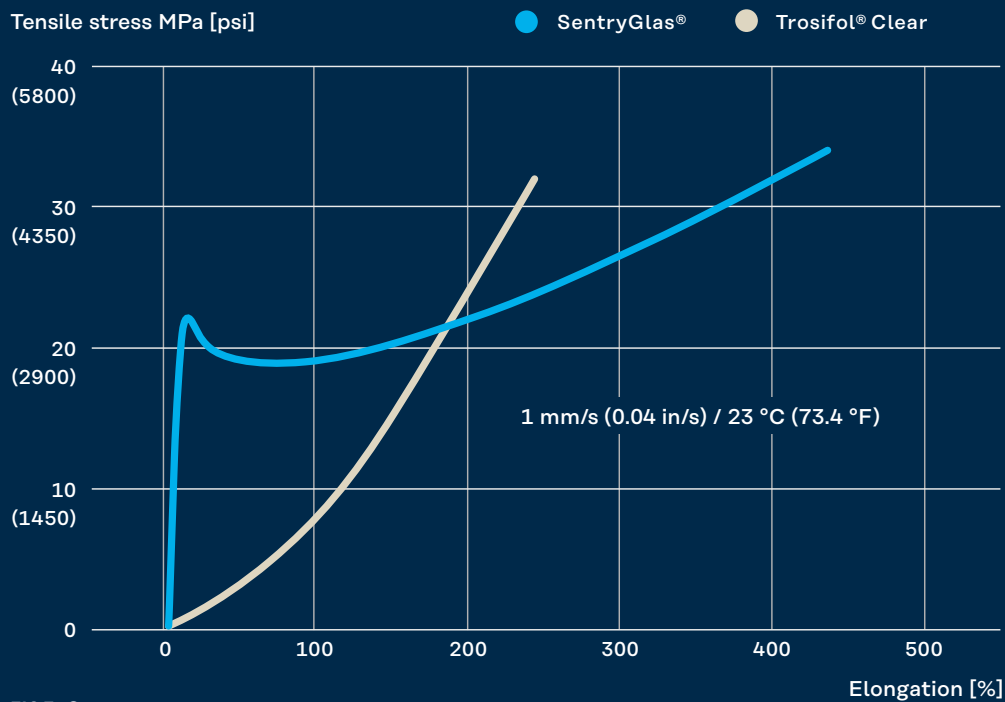
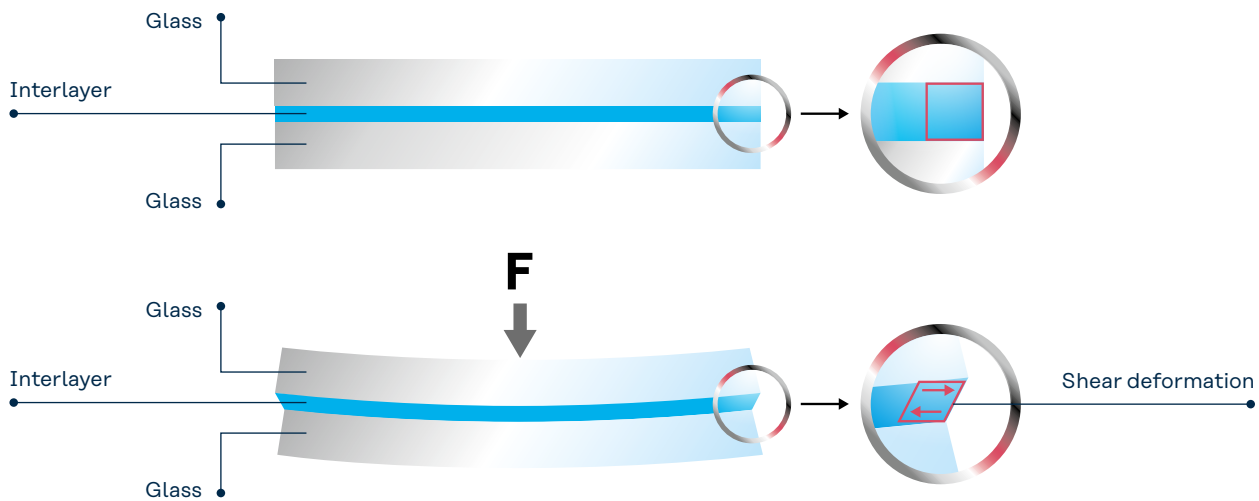

FIG 7

8.9.3. COMPARISON TESTS: SENTRYGLAS® VS TROSIFOL® CLEAR PVB INTERLAYERS

When exposed to sudden, short temporary loads, PVB interlayers such as Trosifol® Clear are able to internally compensate for the distortional differences (i.e. absorb shear forces) due to the glass sheets. Therefore, laminated safety glass produced with PVB interlayer provides excellent protection against, for example, the effects of vandalism, hurricanes or explosions. However, standard PVB is a soft polymer that starts to creep under long-term loads. As a result, two glass sheets laminated together using PVB – and exposed to a long-term flexural load and/or high temperatures - worst case behave in exactly the same way as two sheets that have not been joined together. Therefore, static calculations to date only consider the properties of the glass components and not of the overall laminate coupling effect of laminated safety glass.

Effect under bending load



Laminated safety glass with SentryGlas® interlayers react quite differently to PVB interlayers. In tensile tests, the strength of SentryGlas® is considerably higher than PVB. In addition, the stiffness of SentryGlas® is up to 100 times greater than PVB.

When designing static-loaded laminated glass panels, structural engineers must consider the changes in the mechanical properties and behavior of the interlayer, in particular, the constraints when using PVB rather than SentryGlas® ionoplast. In order to evaluate the elastic properties of laminated safety glass interlayers over a range of specific test temperatures and load duration (time), Kuraray Trosifol™ Solutions has conducted a

series of tests on SentryGlas® (SG5000) interlayers, using dynamic mechanical analysis and creep tests (according to ASTM D 4065). In these tests, the interlayer was subjected to a specific load at different temperatures from 10 °C (50 °F) up to 80 °C (176 °F) for a duration of time ranging from 1 second up to 10 years.

As well as internal tests by Kuraray Trosifol™ Solutions, external independent tests have also been conducted, including comparison tests of SentryGlas®, PVB and monolithic/tempered glass.

Steve Jobs Theater Pavilion, Cupertino, USA



Stiffness (shear modulus) of SentryGlas® Clear PVB and SentryGlas® Interlayers at room and elevated temperatures

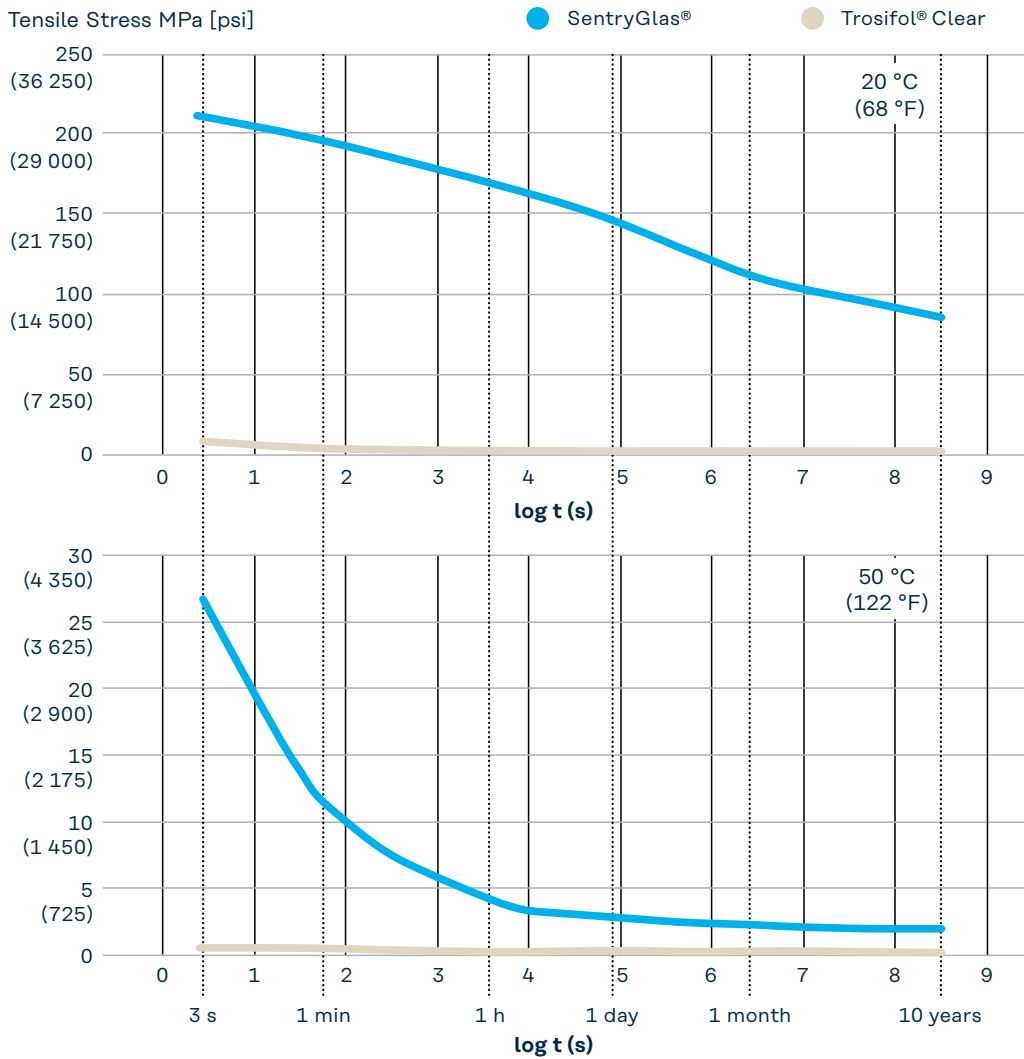

FIG 4 • The stiffness behavior of SentryGlas® at increased temperatures also shows improvements compared to PVB.





Photo: © Faour Glass Technologies

Seminole Hard Rock Hotel & Casino, Hollywood, Florida, USA

8.9.4. RESULTS

The results of all two sets of tests consistently showed that the rate of deflection of laminated safety glass with SentryGlas® was less than half of that with the PVB interlayer, and that this rate of deflection is similar to – or even less than – that recorded with the monolithic sheet. Mechanical tension accumulated in the glass was correspondingly lower.

8.9.5. CONCLUSIONS

The test results above (and subsequent tests) show that the stiffness of SentryGlas® interlayer is so high that there is an almost perfect transfer of load between the glass sheets. This applies to a wide temperature range and also under long-term conditions. This means it is possible to produce high load-bearing laminates from SentryGlas® with exceptional performance / weight ratio. A summary of actual results of interlayer stiffness properties vs. temperature and load duration can be found in the Trosifol Laminators brochure on the website www.trosifol.com.



Photo: © noprat/somchit/shutterstock.com

Chapter 9

Troubleshooting

9.1. Troubleshooting

For any kind of industrial process – in this case glass lamination – excellent control of the raw materials as well as an accurate measurement of the lamination process conditions is essential. Therefore troubleshoot-

ing is an important and effective tool to check all relevant data during the process flow. To solve any kind of upcoming problems this troubleshooting guide gives the laminator the chance to immediately start corrective actions.

Overview

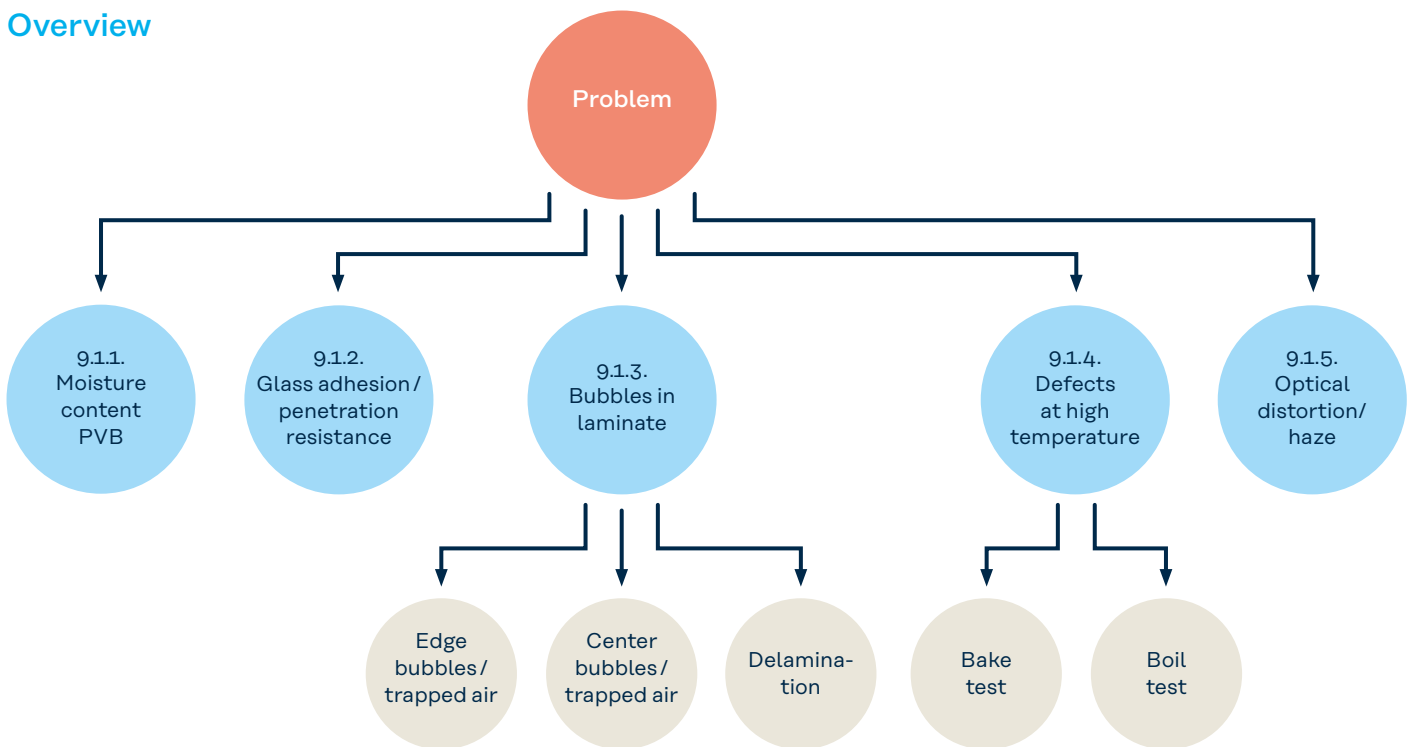

9.1.1. MOISTURE CONTENT

Moisture content

Problem	Cause	Remedy
<p>! Moisture in laminated safety glass too high/too low</p>	<p>? Film /sheet stored at incorrect humidity</p>	<p>✓ Check storage conditions/ packaging</p>
	<p>? Climate in assembly room</p>	<p>✓ Check climate (should be approx. 25-30% rel. humidity)</p>
	<p>? Washed glass not dry</p>	<p>✓ Check washing machine (washing water temperature, dryer, line speed)</p>
	<p>? Prelaminate stored for too long</p>	<p>✓ Shorten storage time to max. 1 day after production</p>
	<p>? Hygrometer not calibrated</p>	<p>✓ Check calibration/moisture standards</p>

9.1.2. GLASS ADHESION / PENETRATION RESISTANCE

Glass adhesion too high or too low / poor ball drop test result*

Problem	Cause	Remedy
<p>! Adhesion too high/too low</p>	<p>? Moisture content</p>	<p>✓ Check PVB/SentryGlas® storage conditions, PVB: 25-30% RH, SentryGlas®: 20-25 % RH (moisture: ≤ 0.20 %)</p>
	<p>? Glass quality</p>	<p>✓ Check origin of glass/coating/glass contamination/storage conditions/ check side of glass facing PVB/ SentryGlas® (air or tin side) with UV lamp</p>
	<p>? Glass washing quality</p>	<p>✓ Check washing conditions/dryness of glass, conductivity of washing water ≤ 20 µS, detergents?</p>
	<p>? Incorrect autoclaving cycle</p>	<p>✓ Check parameters, control instruments</p>
	<p>? Adhesion test</p>	<p>✓ Carry out in accordance with instructions/check with pummel standards (pummel test PVB: -18°C/0°F, SentryGlas: 21°C/70°F), (Trosifol laboratory)</p> <p>Too low adhesion with SentryGlas®: check right glass lay-up ATTA, use low moisture sheeting and check storage conditions and handling method</p>
<p>! Glass fails ball drop test</p>	<p>? Contamination of glass/PVB/ SentryGlas®</p>	<p>✓ Cleanliness in assembly room, cleanliness of glass/PVB/ SentryGlas®</p>
	<p>? Incorrect PVB interlayer type</p>	<p>✓ Change PVB film type, check with Trosifol® and SentryGlas® Technical Service Team</p>
	<p>? Glass/PVB adhesion too high</p>	<p>✓ Check PVB film humidity</p>





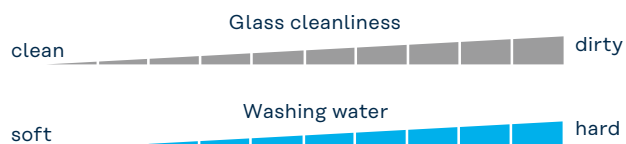
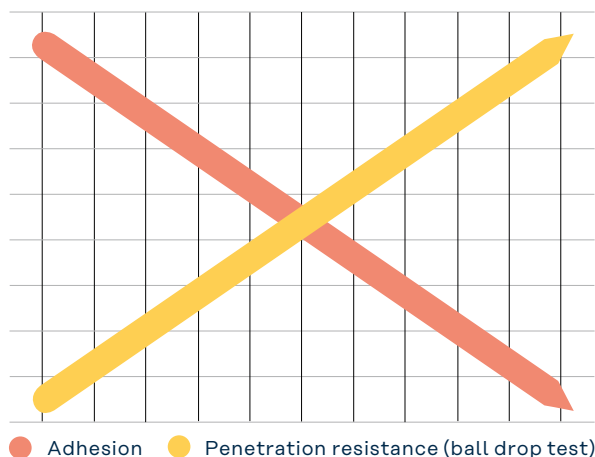

















TAB 59 • * Measurements usually performed with the aid of the pummel or compressive shear test (Chapter 7.4.)

Overview













9.1.3. BUBBLES IN LAMINATE

Edge bubbles / trapped air

Problem	Cause	Remedy
 Fine bubbles at edge after autoclaving	 LSG/PVB film temperature too high after pressure relief	 Prolong cooling in the autoclave process until max. glass temperature of 40°C (104°F) is reached, then release pressure. Immediately after opening the door, check glass temperature with measuring instrument; calibrate measuring sensor/ autoclave if necessary
 Larger bubbles at edge/ local bubbling	 Poor edge seal after prelamination	 Improve by increasing temperature during prelamination
	 Premature edge seal after prelamination	 Improve by reducing temperature during prelamination; reduce nip roll speed
	 Creasing due to incorrectly laid film	 Assembly room/staff training
	 Film pulled out before cutting (too thin or missing, only PVB)	 Assembly room/staff training
	 Glass plies offset or poorly bent	 Make sure plies match up; observe bending tolerances
	 Suboptimal autoclaving process (pressure increase too low/high in relation to temperature, pressure relief at excessively high temperature)	 Optimise process in accordance with recommendation
	 Autoclave support tools/separators too soft	 Use harder support tools/separators, e.g. Teflon or PMMA strips
	 Unequal heating causes air pockets to form on side of the interlayer	 Adjust top or bottom furnace heaters so that the temperatures are equal
	 Trapped air is randomly distributed in small areas due to excessive line speed (≥ 15 ft./min. or 4.5 m/min.)	 Decrease belt line speed (may require lower furnace temperature)















TAB 60

Center bubbles / trapped air

Problem	Cause	Remedy
 Bubbles everywhere	 Incorrect prelaminating conditions (de-airing temperature too high or too low)	 Change machine settings, e.g. heater temperature, feed, etc. Reduce speed but with same temperature
	 Poor de-airing due to incorrectly set rolls/roll pressure	 Check nip roll and/or vacuum pressure
	 Premature edge seal	 See section on edge bubbles (chapter 4.4.)
	 Suboptimal autoclaving process	 See section on edge bubbles and recommendations (chapter 4)
	 Wrinkles in PVB film	 See section on edge bubbles (chapter 4.4.)

TAB 61

Delamination













Problem	Cause	Remedy
 Delamination locally or in large area	 Adhesion too low	 Check quality of washing water, conductivity $\leq 20 \mu\text{S}$
		 Too little/too much detergent in washing water (dirt or cutting oils as residue on glass)
		 Check dryness of washed glass
		 Check washing brush setting, replace brushes if necessary
		 Check film moisture / climate in assembly room
		 Check flatness of fully tempered / heat-strengthened glass with template
		 Check glass bending tolerances
		 Check prelaminating conditions / autoclaving parameters, see section on edge bubbles
		 Screen printing on glass: check compatibility in relation to extent of printing
	 PVB outflow at edge because autoclave temperature is too high	 Reduce autoclave temperature, shorten process time slightly if necessary
	 Residual bending powder or other release agent on glass	 Prevent contamination by removing bending powder / release agent

9.1.4. DEFECTS AT HIGH TEMPERATURE

Bake test

If bubbles occur on the original or cut edge at temperatures below 130°C (266 °F), the moisture content in the laminated safety glass is too high or de-airing of the pre laminate has been insufficient. Other causes are also possible – as mentioned in the section moisture.













Boil test 2h/100°C (212°F)

Problem	Cause	Remedy
 Bubbles in laminated safety glass	 Film pattern too smooth	 Contact Trosifol® and SentryGlas® Technical Service
	 Wrinkles in PVB	 Change processing conditions, see section on edge bubbles
	 Faulty glass alignment/ glass bending tolerances too high	 Check tolerances/optimize glass alignment
	 Glass temperature too high during assembly	 Check washing conditions, see section on delamination (chapter 4.4.)
	 Incorrect prelaminating conditions/premature edge seal/ nip too wide	 See section on edge bubbles and bubbles in interior (chapter 4.4.)
	 Moisture content in the PVB too high	 Check climate setting/assembly room

TAB 63

9.1.5. OPTICAL DISTORTION / HAZE

Laminated safety glass partially defect

Problem	Cause	Remedy
 Optical distortion after autoclaving	 Uneven temperature distribution in autoclave	 Check working of autoclave (fan, indicators etc.)
	 Pressure points causing thinner film and weaker color (on colored films) due to excessively tight clamping of the glass in the autoclave	 Check clamping type and pressure
	 Too high waviness of curved glass	 Check glass waviness
 High Haze (SentryGlas®)	 Autoclave cooling rate too slow or non-uniform	 Ensure cooling rate is 2°C/min. (4 °F/min.) with good unobstructed airflow
 Iridescence (SentryGlas®)	 Laminate has high stress areas during autoclaving	 Eliminate any uneven stresses on the laminate and ensure the proper laminate separators are used

TAB 64

Tools & Apps

WINSLT

For calculating the light, solar and heat parameters of glazing specifically containing films from the Trosifol® & SentryGlas® product range.

SOUNDLAB AI

First global acoustic calculator based on artificial intelligence for calculating/estimating acoustic performance of monolithic, double and triple glazed units.

SOLUTION FINDER

For finding the right product of your project.

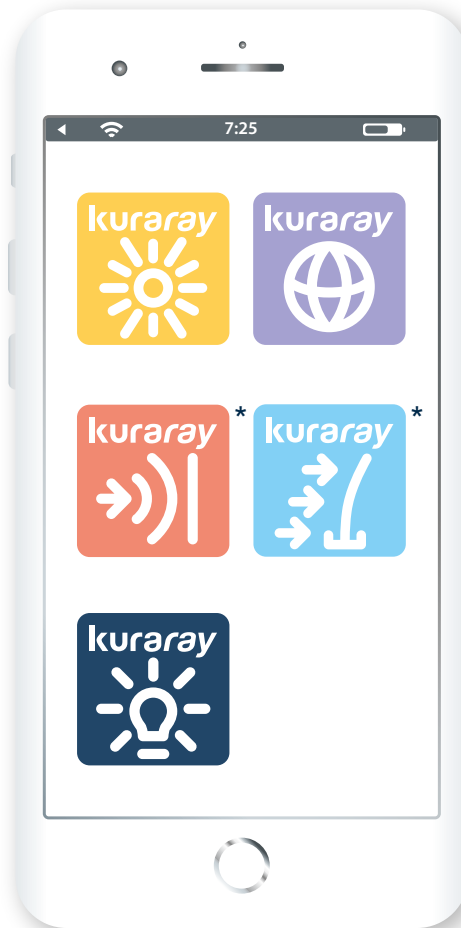

GLASGLOBAL

For performing structural analysis for glass.

STRENGTH LAB AI

The goal of the Strength Lab AI tool is to provide designers, engineers, and architects with an efficient tool to facilitate the design and evaluation of glazing systems in terms of structural properties. This tool provides rapid analysis of virtually any glazing configuration, dimension and load case. Additionally, standard modules allow easy evaluation of results according to ASTM, EN and DIN standards.

* Only available as web app



Contact



FOR FURTHER INFORMATION

on products from Kuraray, please visit www.kuraray.com.

You can find further information on our Trosifol® and SentryGlas® products at www.trosifol.com.

Kuraray America, Inc.

Advanced Interlayer Solutions Division
 Wells Fargo Tower
 2200 Concord Pike, Ste. 1101
 Wilmington, DE 19803, USA
 P +1 800 635 3182

Kuraray Europe GmbH

Advanced Interlayer Solutions Division
 Kronenstr. 55
 53840 Troisdorf
 Germany
 P +49 2241 2555 226

Kuraray Co., Ltd

Advanced Interlayer Solutions Division
 Tokiwabashi Tower
 2-6-4 Otemachi, Chiyoda-ku
 Tokyo 100-0004, Japan
 P +813 6701 1508

trosifol@kuraray.com

2/2024

Copyright © 2024 Kuraray. All rights reserved.

Trosifol, Butacite, SentryGlas, SG, SentryGlas Xtra, SGX, SentryGlas Acoustic, SGA and Spallshield are trademarks or registered trademarks of Kuraray Co., Ltd. or its affiliates. Trademarks may not be applied for or registered in all countries. The information, recommendations and details given in this document have been compiled with care and to our best knowledge and belief. They do not entail an assurance of properties above and beyond the product specification. Final determination of suitability of any material or process and whether there is any infringement of patents is the sole responsibility of the user.

WORLD OF INTERLAYERS

**What is the next project
you are dreaming of?**

**trosifol@kuraray.com
www.trosifol.com**

